

Adjustable Sliding Gate orifice 8090 SCHUBERT & SALZER

Series GS3 - 1/2" to 10"

Continuously adjustable sliding gate orifice plate for precise adjustment of a defined flow rate

- Infinitely adjustable in the built-in status
- Manual adjustment with safety device
- Optional sealable
- Defined characteristic curve
- Stops at the end positions
- Space-saving intermediate flange construction
- Very light weight
- Insensitive to cavitation
- Meets the requirements of TA-Luft 2021

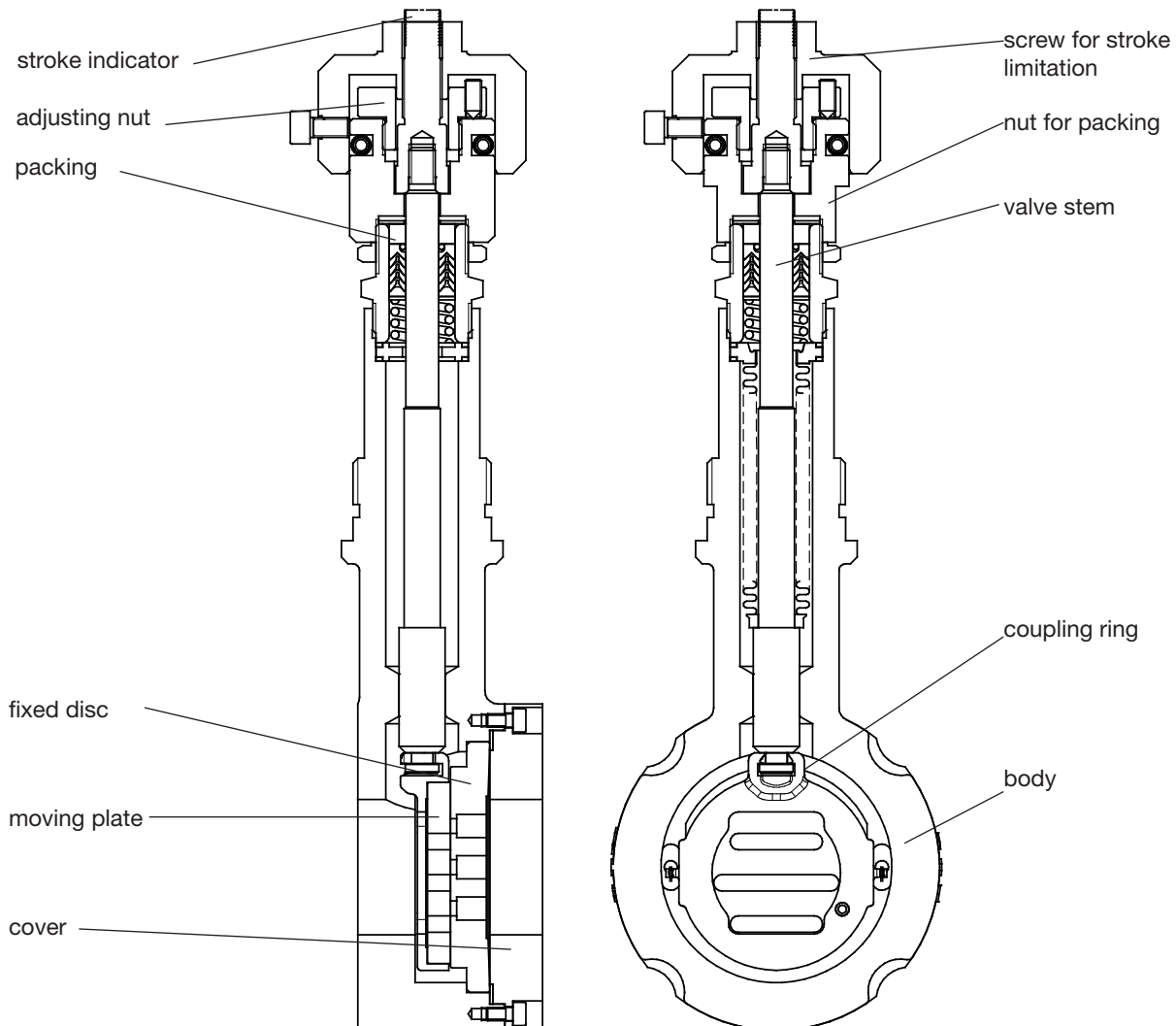

Technical information

Body design	ANSI flange wafer (self-aligning) for flanges acc. ASME B16.5 RF or DIN EN 1092-1 Form B		
Nominal sizes	1/2" - 10"		
Nominal pressure acc. DIN 2401	580 psi (fits also to 145-365 psi) 1450 psi 235 psi	1/2" - 6" 1/2" - 4" 8" - 10"	
Nominal pressure acc. ANSI	ANSI 150 ANSI 300 ANSI 600	1/2" - 10" 1/2" - 6" 1/2" - 4"	
Flange gaskets (customer side)	ANSI B16.21 or DIN EN 1514-1 in the respective nominal pressure rating		
Media temperature	Versions from -76°F up to +662°F		
Leakage	Disc pair Carbon-stainless steel	Disc pair SFC	Disc pair STN 2
% of Kvs	< 0,0001	< 0,0005	< 0,001
IEC 60534-4	IV-S1	IV-S1	IV
EN 12266-1	E	F	F
Packing leakage	tested according to TA-Luft as defined in DIN EN ISO 15848-1 and VDI 2440		
Ambient temperature	From -22°F to +284°F		

Application limits

Rating	PN40	PN 16	PN 100	ANSI 150	ANSI 300	ANSI 600
Body material cpl. stainless steel						
Tmin [°F]	-76	-76	-76	-20	-20	-20
Tmax [°F]	662	662	662	662	662	662
Body material carbon steel with stainless steel body cover						
Tmin [°F]	-76	-76	14	-4	-4	-4
Tmax [°F]	662	662	662	662	662	662

Materials

Body	Stainless steel CF8M	Carbon steel WCB
Bodycover	Stainless steel 316 L	
Packing	PTFE (Carbon filled), spring SST 301	
Actuating stem	Stainless steel 316 Ti, roller burnished	
Bellows	Stainless steel 316 Ti	
Fixed disc	Stainless steel 316 Ti, coated	STN2-disc
Sliding disc	Special carbon material	STN2-disc
Guide ring for sliding disc	Stainless steel 316 Ti	

Admissible Differential Pressure

DN	carbon/SFC-stain- less steel	STN2
	max. differential pressures	
	psi	psi
15	1480	1480
20	1480	1480
25	1276 (1480)*	1276 (1480)*
32	1480	1480
40	1276 (1480)*	1044
50	1480	1117
65	1160	899
80	696	522
100	479	479
125	334	319
150	232	232
200	232	131
250	152	80

*figures in brackets for bodys made of carbon steel

	Pressure limits ANSI and DIN in psi					
	ANSI150	ANSI300	ANSI600	PN16	PN40	PN100
P max. carbon steel	284	741	1480	232	580	1450
P max. stainless steel	276	719	1440			

Ordering number system

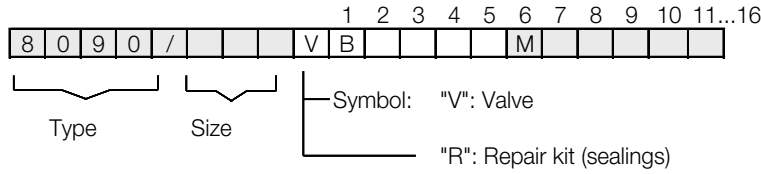

1 - 5 : Please quote all 5 sections.
6 - 16: Quote only if required.

1. Type	2. Connection	3. Body material	4.	5. Actuator	6. Special versions
B Adjustable GS orifice 8090 (long version)	E GS3-flangeless design acc. ANSI 150 F GS3-flangeless design acc. ANSI 300 K GS3-flangeless design acc. ANSI 600 G GS3-flangeless design acc. DIN, 145 - 580 psi H GS3-flangeless design acc. DIN, 1450 psi N GS3-flangeless design acc. JIS-20K (suitable f. JIS-16K/-10K, DN50 only in JIS-10K)	0 C-steel ASTM A216 WCB 1 stainless steel CF8M	- without significance	A manually operated	M special versions (Pos. 7-17) A nut and nut acc. DIN EN1092-1 C nut and tongue acc. DIN EN1092-1 E 2x lowered face acc. DIN EN1092-1 H lowered and raised face acc. DIN EN1092-1
7.	8. Stem sealing	9. Moving valve disc	10. Fixed valve disc	11. Kvs-values	12. Flow characteristic
- without significance	- PTFE-packing, self adjusting (standard) 1 additional bellows 1.4571 7 Pack for lower temperatures, down to -76°F	- carbon material 9 STN2/STN3 T HMC H hardmetal	- standard coating 1 STN2 3 STN3 3 STN3 H hardmetal	- 100 % (Stand.) S Special-Kvs-value	- linear 1 equal%

Ordering example: 8090/015VB00AM--91--Z-1
Adjustable GS orifice, size 1/2" (Kvs 4; Cv 4,6), long verion, GS3-flangeless design acc. DIN, PN10-PN40, body material carbon steel, stem sealing PTFE-packing, pair of sealing discs: STN2/STN3, characteristic linear 100%, additional locking nut

Optional with locking nut and locking plate

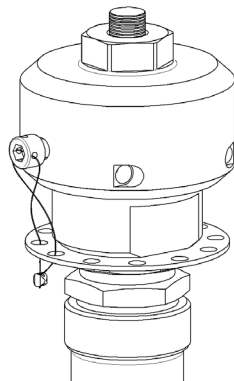

Dimensions and weights

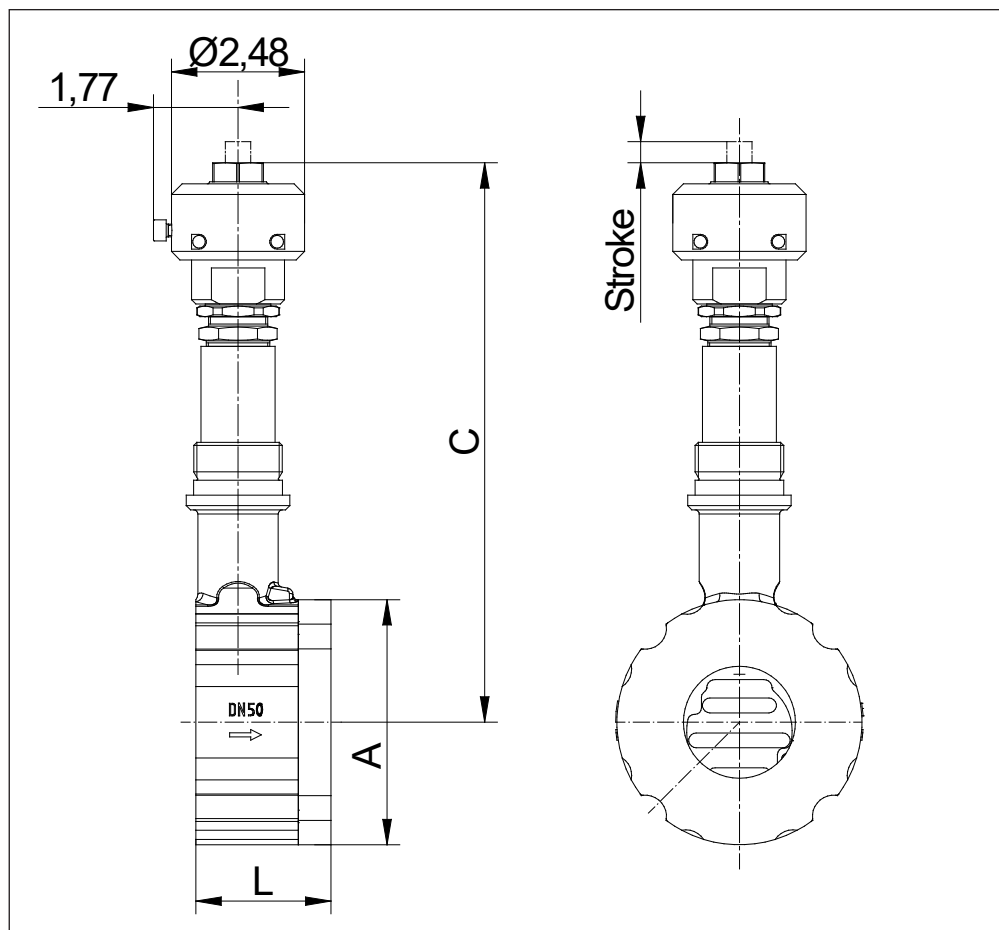

Size	A	C max	L	Weigh lbs	Stroke H
1/2"	2.5	9.3	2.2	11,20	0.2
3/4"	2.85	9.5	2.2	11,70	0.19
1"	3.25	9.7	2.2	12,30	0.19
1 1/4"	3.5	9.9	2.2	12,80	0.19
1 1/2"	3.9	10.1	2.2	13,20	0.19
2"	4.55	10.45	2.5	16,30	0.26
2 1/2"	5.45	10.85	2.7	19,40	0.26
3"	6	11.25	2.75	22,00	0.26
4"	7.25	11.65	2.95	28,20	2.83
5"	8.35	12.25	3.15	32,20	0.28
6"	9.55	12.85	3.15	40,10	0.26
8"	11.9	14	3.65	50,00	0.26
10"	14.15	15	3.8	84,20	0.26

dimensions in inch

Flow Coefficients - Cv-values

Ordering code	-	A	1	B	6	2	7	C	3	4	8	5	9	
Size	Charact.	100 %	63 %	40 %	25 %	20%	16 %	12 %	10 %	6,3 %	2,5 %	2 %	1 %	0,4%
1/2"	(mod.) linear	4.6	3	2	1.6	-	0.82	0.57	0.51	0.3	0.16	0.09	0.05	0.021
	eq. perc.	2	-	1.3	-	0.4	-	-	-	0.12	-	-	-	-
3/4"	(mod.) lin.	7.4	-	-	-	-	1.16	-	-	-	-	0.15	-	-
	eq. perc.	3.5	-	1.7	-	-	-	-	-	-	-	-	-	-
1"	(mod.) linear	13	7.4	4.6	-	-	1.9	-	1.08	0.72	0.3	-	0.16	0.05
	eq. perc.	5.8	-	2.8	-	1.3	-	-	-	0.41	-	-	-	-
1	(mod.) linear	19	12	-	-	-	-	-	-	-	-	-	-	-
1/4"	eq. perc.	9.3	5.45	-	-	-	-	-	-	-	-	-	-	-
1	(mod.) lin.	30	19	13	8.1	-	-	-	-	-	-	-	-	-
1/2"	eq. perc.	13	9.9	-	3.2	-	-	-	-	-	-	-	-	-
2"	(mod.) linear	52	32	23	14	12	-	-	-	-	-	-	-	-
	eq. perc.	22	14	-	-	-	-	3.5	-	-	-	-	-	-
2	(mod.) linear	60	41	-	17	-	-	-	-	-	-	-	-	-
1/2"	eq. perc.	35	-	-	9.3	-	-	-	-	-	-	-	-	-
3"	(mod.) linear	107	67	46	-	-	-	-	-	-	-	-	-	-
	eq.perc.	56	41	-	-	-	-	-	-	-	-	-	-	-
4"	(mod.) linear	179	110	72	-	-	-	-	-	-	-	-	-	-
	eq.perc.	89	56	-	-	-	-	-	-	-	-	-	-	-
5"	(mod.) linear	275	-	110	-	-	-	-	-	-	-	-	-	-
	eq.perc.	135	-	-	-	-	-	-	-	-	-	-	-	-
6"	(mod.) linear	392	246	-	-	-	-	-	-	-	-	-	-	-
	eq.perc.	171	104	-	-	-	-	-	-	-	-	-	-	-
8"	(mod.) linear	650	408	-	-	-	-	-	-	-	-	-	-	-
	eq.perc.	329	-	-	-	-	-	-	-	-	-	-	-	-
10"	(mod.) linear	1056	667	-	-	-	-	-	-	-	-	-	-	-
	eq.perc.	-	-	-	-	-	-	-	-	-	-	-	-	-