

Sliding Gate Motor Valve 8037



Version for potentially explosive areas
GS 3 series, DN 15 up to DN 250

Sliding gate motor valve for control and switching of neutral through to highly aggressive media in process engineering, chemical industries and for plant equipment, for applications in ATEX zones 1, 2, 21 and 22.

Technical data of the valve

Design	wafer-type design -for flanges acc. DIN EN 1092-1 Form B or ASME B16.5 RF - with threaded connection (only PN40 in stainless steel; DN15 - DN50)	
Nominal Sizes	DN 15 - 250	
Nominal pressure acc. EN 1333	PN 40 (fits also to PN10-PN25) PN 100 (fits also to PN63) PN 16 and PN 25	DN 15 - DN 150 DN 15 - DN 80 DN 200 - DN 250
Nominal pressure acc. ASME B16.5	ANSI 150 ANSI 300 ANSI 600	DN15 - DN 250 DN 15 - DN 150 DN 15 - DN 80
Nominal pressure acc. JIS for flanges with raised face	10K 20K	DN 15 - DN 50 DN 15 - DN 40
Fluid Temperature	Versions from -60°C up to 350°C	
Rangeability / Characteristic	30:1	
Specific leakage rate shaft and body sealing	ISO FE-BH-CC3-SSA0-t(-40°C/+350°C)-PN40-ISO 15848-1	
Applications acc. DGRL 2014/68/EU	stainless steel or carbon steel body body made of Alloy C-276 body made of stainless steel with threaded ends	up to category II up to category I up to category I

Technical data of the actuator type 2036

Driving force	2 kN
Stroking speed	3.3 s/mm (actuator with spring return), 1/1,3/2 s/mm (actuator without spring return adjustable)
Power supply	24 V AC/DC or 100-240 V AC
Input signal	(0) 4 - 20 mA, (0) 2 - 10 V or binary (3-point)
Feedback	(0) 4 - 20 mA or (0) 2 - 10 V
Explosion protection	II 2G Ex db eb [ib Gb] IIC T6, T5, T4 Gb II 2D Ex tb [ib Db] IIIC T80°C, T95°C, T130°C Db
Protection class	IP 65
Ambient temperature	-10°C ≤ Ta ≤ +40°C (T6) / +60°C (T4)
Operating mode	S2 30 min / S4 50% ED
Hysteresis	approx. ±1,5%
Ambient	self-learning
Motor	brushless DC motor
Manual operation	by means of pressure switch (power supply required) or with handwheel as emergency actuation
Zero-voltage reset	Mechanical spring return



Technical data of the actuator type 2037

Driving force	1 kN	2,5 kN	5 kN
Stroking speed	2 / 3 / 6 / 9 / 12 s/mm (adjustable)		
Power supply	24 ... 230 V AC/DC (multi-range power supply unit)		
Input signal	3-point or 4 - 20 mA resp. 0 - 10 V		
Feedback	4 - 20 mA or 0 - 10 V		
Explosion protection	II 2G Ex db eb [ib Gb] IIC T6, T5, T4 Gb II 2D Ex tb [ib Db] IIIC T80°C, T95°C, T130°C Db		
Protection class	IP 66		
Ambient temperature	-20...+40°C for T6 / -20...+50°C for T5		
Operating mode	S3 / 50% ED (max. 300 switching cycles / h)		
Hysteresis	approx. ±1,5%		
Resolution	approx. 100 Schritte		
Ambient temperature	self-learning		
Heating resistor element	16 Watt self actuating		
Motor	brushless DC motor		
Manual operation	hexagon key (top of header)		



Medium temperature

Rating	PN16 - PN40	PN 100	ANSI 150	ANSI 300	ANSI 600
Body material cpl. stainless steel					
Tmin [°C]	-60	-60	-29	-29	-29
Tmax [°C]	350	350	350	350	350
Body material carbon steel with stainless steel body cover					
Tmin [°C]	-60	-10	-20	-20	-20
Tmax [°C]	350	350	350	350	350
Body material Alloy C-276					
Tmin [°C]	-60	-60	-29	-29	-29
Tmax [°C]	350	350	350	350	350

Materials Special versions

Version in stainless steel	
Valve body	Stainless steel , 1.4408
Bodycover	Stainless steel, 1.4404 resp. 316L
Valve stem	Stainless steel, 1.4571
Coupling ring	Stainless steel, 1.4581
Tube for packing	Stainless steel 1.4408
Packing	PTFE filled with carbon (Spring 1.4310)
Body seal	Graphite with stainless steel inlay
Version in C-steel	
Valve body	C-steel, 1.0619
Bodycover	Stainless steel, 1.4404 resp. 316L
Valve stem	Stainless steel, 1.4571
Coupling ring	Stainless steel, 1.4581
Tube for packing	Stainless steel, 1.4408
Packing	PTFE filled with carbon (spring 1.4310)
Body seal	Graphite with stainless steel inlay
Version in Alloy C-276	
Valve body	Alloy C-276, 2.4819
Bodycover	Alloy C-276, 2.4819
Valve stem	Alloy C-276, 2.4819
Coupling ring	Alloy C-276, 2.4819
Tube for packing	Alloy C-276, 2.4819
Packing	PTFE filled with carbon (spring Alloy C4, 2.4610)
Body seal	Pure graphite

Kvs values

Ordering code	-	A	1	B	6	2	7	C	3	4	8	5	9	
DN	Charact.	100 %	63 %	40 %	25 %	20%	16 %	12 %	10 %	6,3 %	2,5 %	2 %	1%	0,4%
15	(mod.) linear	4	2,6	1,7	1,4	-	0,71	0,49	0,44	0,26	0,14	0,08	0,04	0,018
	eq. perc.	1,7	-	1,1	-	0,35	-	-	-	0,1	-	-	-	-
20	(mod.) linear	6,4	-	-	-	-	1	-	-	-	-	0,13	-	-
	eq. perc.	3	-	1,5	-	-	-	-	-	-	-	-	-	-
25	(mod.) linear	11	6,4	4	-	-	1,6	-	0,93	0,62	0,26	-	0,14	0,04
	eq. perc.	5	-	2,4	-	1,1	-	-	-	0,35	-	-	-	-
32	(mod.) linear	16	10	-	-	-	-	-	-	-	-	-	-	-
	eq. perc.	8	4,7	-	-	-	-	-	-	-	-	-	-	-
40	(mod.) linear	26	16	11	7	-	-	-	-	-	-	-	-	-
	eq. perc.	11	8,5	-	2,75	-	-	-	-	-	-	-	-	-
50	(mod.) linear	45	28	20	12	10	-	-	-	-	-	-	-	-
	eq. perc.	19	12	-	-	-	3	-	-	-	-	-	-	-
65	(mod.) linear	52	35	-	15	-	-	-	-	-	-	-	-	-
	eq. perc.	30	19	-	8	-	-	-	-	-	-	-	-	-
80	(mod.) linear	92	58	40	-	-	-	-	-	-	-	-	-	-
	eq.perc.	48	35	-	-	-	-	-	-	-	-	-	-	-
100	(mod.) linear	154	95	62	-	-	-	-	-	-	-	-	-	-
	eq.perc.	77	48	-	-	-	-	-	-	-	-	-	-	-
125	(mod.) linear	237	-	95	-	-	-	-	-	-	-	-	-	-
	eq.perc.	116	-	-	-	-	-	-	-	-	-	-	-	-
150	(mod.) linear	338	212	-	-	-	-	-	-	-	-	-	-	-
	eq.perc.	147	90	-	-	-	-	-	-	-	-	-	-	-
200	(mod.) linear	560	352	-	-	-	-	-	-	-	-	-	-	-
	eq.perc.	284	-	-	-	-	-	-	-	-	-	-	-	-
250	(mod.) linear	910	575	-	-	-	-	-	-	-	-	-	-	-
	eq.perc.	435	-	-	-	-	-	-	-	-	-	-	-	-

Definition of the Kvs-Value:

The Kvs-value corresponds to the volume flow of water (m³/h), passing the valve if a pressure difference of 1 bar is applied. Kvs is the Kv-value for a fully opened valve from the series production (acc. DIN IEC 534).

Operating times for full valve stroke (sec)

Operating times for full valve stroke (sec) type 2036 with spring return

Geschwindigkeit [s/mm]	3,3
DN 15 - 40	20,6
DN 50 - 80	27,2
DN 100 - 250	28,9

= Factory setting actuator type 2036 with spring return

Operating times for full valve stroke (sec) type 2036 and 2037 without spring return

Geschwindigkeit [s/mm]	1	1,3	2	3*	6*	9*	12*
DN 15 - 40	6,3	8,1	12,5	18,8	37,5	56,3	75,0
DN 50 - 80	8,3	10,7	16,5	24,8	49,5	74,3	99,0
DN 100 - 250	8,8	11,4	17,5	26,3	52,5	78,8	105,0

= Factory setting actuator type 2036 without spring return

= Factory setting actuator type 2037

*Setting only for type 2037

Admissible differential pressures

For temperatures up to 120°C at PN pressure stages up to 38°C at ANSI pressure stages, at high temperatures the application limits must be taken into account.

DN	1,0 kN	2,0 kN	2,5 kN	5,0 kN	1,0 kN	2,0 kN	2,5 kN	5,0 kN
	Maximum differential pressure (bar)				Maximum differential pressure (bar)			
	Carbon material/SFC stainless steel coated pairing				STN2 sliding pair			
15	88,3	102,1	102,1	102,1	62,7	102,1	102,1	102,1
20	76,7	102,1	102,1	102,1	48,3	101,8	102,1	102,1
25	64,2	88 (102,1)*	88 (102,1)*	88 (102,1)*	36,1	76,1	88 (96,2)*	88 (102,1)*
32	52,6	102,1	102,1	102,1	26,8	56,6	71,5	102,1
40	39,8	84	88 (100)*	88 (100)*	18,4	38,8	49,1	72,6
50	26,1	55,1	69,6	100	11	23,2	29,3	59,9
65	22	46,4	58,6	80	9	19	24	49,1
80	14	29,5	37,2	48	5,5	11,5	14,5	29,7
100	8,9	18,8	23,8	33	3,4	7,1	9	18,4
125	6,1	12,8	16,2	23	2,3	4,7	6	12,3
150	4,5	9,5	12,1	16	1,7	3,5	4,5	9,1
200	2,6	5,5	7	14,3	0,9	2	2,5	5,2
250	1,6	3,4	4,3	8,8	0,5	1,2	1,5	3,1

*: figures in brackets for bodies made of carbon steel

Upper limits of the pressure rating

	Upper limits for admissible pressures in bar					
	PN16	PN40	PN100	ANSI150	ANSI 300	ANSI 600
P max. carbon steel/ Alloy C-276	16	40	100	19,6	51,1	102,1
P max. stainless steel				19,0	49,6	99,3

Application limits for GS3 valves made out of stainless steel

The actual maximum permissible operating pressure of the valve results from the minimum value of the pressure tables, the limitation by the pressure rating, the category according to DGRL 2014/68/EU and the application limits listed here. These pressures must not be exceeded for GS valves of the GS3 series made of stainless steel, even if the tensile force of the actuator would allow this.

PN16 + PN25

DN	Movable sealing disc carbon or SFC						Movable sealing disc STN2, STN3 or hard metal					
	max. admissible pressures for GS3-valves in stainless steel						max. admissible pressures for GS3-valves in stainless steel					
	100°C	150°C	200°C	250°C	300°C	350°C	100°C	150°C	200°C	250°C	300°C	350°C
200 (max. PN25)	16	16	15	13	12	11	8	7	6	5	4	3
250 (max. PN25)	10	9	9	8	7	6	5,7	5,4	5,1	4,1	3,4	2,9

Limitation for SFC-sliding discs: 300°C

PN40

DN	Movable sealing disc carbon or SFC						Movable sealing disc STN2, STN3 or hard metal					
	max. admissible pressures for GS3-valves in stainless steel						max. admissible pressures for GS3-valves in stainless steel					
	100°C	150°C	200°C	250°C	300°C	350°C	100°C	150°C	200°C	250°C	300°C	350°C
15-32	40	40	40	40	40	40	40	40	40	40	40	40
40	40	40	40	40	40	40	40	40	40	40	40	37
50	40	40	40	40	40	40	40	40	40	40	40	40
65	40	40	40	40	40	40	40	40	40	37	32	32
80	40	40	40	40	40	40	36	34	33	26	22	19
100	33	33	33	33	33	33	32	31	30	24	20	17
125	23	23	23	23	23	23	21	21	19	16	13	11
150	16	16	16	16	16	16	15	15	14	11	9	8

Limitation for SFC-sliding discs: 300°C

PN100

DN	Movable sealing disc carbon or SFC						Movable sealing disc STN2, STN3 or hard metal					
	max. admissible pressures for GS3-valves in stainless steel						max. admissible pressures for GS3-valves in stainless steel					
	100°C	150°C	200°C	250°C	300°C	350°C	100°C	150°C	200°C	250°C	300°C	350°C
15	100	100	100	93	84	79	100	100	100	93	84	79
20	100	100	89	81	73	68	100	100	89	81	73	68
25	88	81	70	63	57	54	88	81	70	63	57	54
32	100	93	80	73	65	62	100	93	80	73	65	60
40	88	81	70	63	57	54	72	69	65	53	43	37
50	100	100	100	100	100	94	77	73	70	56	46	40
65	80	80	80	79	71	67	62	59	56	45	37	32
80	48	48	48	48	48	44	36	34	33	26	22	19

Limitation for SFC-sliding discs: 300°C

ANSI150

DN	Movable sealing disc carbon or SFC								Movable sealing disc STN2, STN3 or hard metal							
	max. admissible pressures for GS3-valves in stainless steel								max. admissible pressures for GS3-valves in stainless steel							
	38°C	50°C	100°C	150°C	200°C	250°C	300°C	350°C	38°C	50°C	100°C	150°C	200°C	250°C	300°C	350°C
15-125	19,0	18,4	16,2	14,8	13,7	12,1	10,2	8,4	19,0	18,4	16,2	14,8	13,7	12,1	10,2	8,4
150	16,0	16,0	16,0	14,8	13,7	12,1	10,2	8,4	16,2	16,2	16,2	14,8	13,7	11,8	9,7	8,4
200	16,0	16,0	16,0	14,8	13,7	12,1	10,2	8,4	10,5	10,0	8,3	7,6	6,9	5,5	4,5	3,9
250	10,4	10,4	10,4	9,9	9,4	8,4	7,4	6,8	5,7	5,7	5,7	5,4	5,1	4,1	3,4	2,6

Limitation for SFC-sliding discs: 300°C

ANSI300

DN	Movable sealing disc carbon or SFC								Movable sealing disc STN2, STN3 or hard metal							
	max. admissible pressures for GS3-valves in stainless steel								max. admissible pressures for GS3-valves in stainless steel							
	38°C	50°C	100°C	150°C	200°C	250°C	300°C	350°C	38°C	50°C	100°C	150°C	200°C	250°C	300°C	350°C
15-65	49,6	48,1	42,2	38,5	35,7	33,4	31,6	30,3	49,6	48,1	42,2	38,5	35,7	33,4	31,6	30,3
80	48,0	48,0	42,2	38,5	35,7	33,4	31,6	30,3	36,6	36,6	36,6	34,8	33,0	26,8	22,0	19,0
100	33,0	33,0	33,0	33,0	33,0	33,0	31,6	30,3	33,0	33,0	33,0	31,7	30,1	24,4	20,1	17,3
125	23,0	23,0	23,0	23,0	23,0	23,0	23,0	23,0	22,0	22,0	22,0	21,0	19,9	16,1	13,2	11,5
150	16,0	16,0	16,0	16,0	16,0	16,0	16,0	16,0	16,0	16,0	16,0	15,4	14,6	11,8	9,7	8,4
200	16,0	16,0	16,0	14,8	13,7	12,1	10,2	8,4	10,5	10,0	8,3	7,6	6,9	5,5	4,5	3,9

Limitation for SFC-sliding discs: 300°C

ANSI600

DN	Movable sealing disc carbon or SFC								Movable sealing disc STN2, STN3 or hard metal							
	max. admissible pressures for GS3-valves in stainless steel								max. admissible pressures for GS3-valves in stainless steel							
	38°C	50°C	100°C	150°C	200°C	250°C	300°C	350°C	38°C	50°C	100°C	150°C	200°C	250°C	300°C	350°C
15-20	99,3	96,2	84,4	77,0	71,3	66,8	63,2	60,7	99,3	96,2	84,4	77,0	71,3	66,8	63,2	60,7
25	88,0	88,0	84,4	77,0	70,1	63,7	57,3	54,2	88,0	88,0	84,4	77,0	70,1	63,7	57,3	54,2
32	99,3	96,2	84,4	77,0	71,3	66,8	63,2	60,7	99,3	96,2	84,4	77,0	71,3	66,8	63,2	60,2
40	88,0	88,0	84,4	77,0	70,1	63,7	57,3	54,2	72,5	72,5	72,5	69,0	65,5	53,1	43,6	37,7
50	99,3	96,2	84,4	77,0	71,3	66,8	63,2	60,7	77,7	77,7	77,7	73,9	70,2	56,9	46,7	40,4
65	80,0	80,0	80,0	77,0	71,3	66,8	63,2	60,7	62,5	62,5	62,5	59,5	56,4	45,8	37,6	32,5
80	48,0	48,0	48,0	48,0	48,0	48,0	48,0	44,5	36,6	36,6	36,6	34,8	33,0	26,8	22,0	19,0

Limitation for SFC-sliding discs: 300°C

Application limits for GS3 valves made out of carbon steel

The actual maximum permissible operating pressure of the valve results from the minimum value of the pressure tables, the limitation by the pressure rating, the category according to DGRL 2014/68/EU and the application limits listed here. These pressures must not be exceeded for GS valves of the GS3 series made of carbon steel, even if the tensile force of the actuator would allow this.

PN16 + PN25

DN	Movable sealing disc carbon or SFC						Movable sealing disc STN2, STN3 or hard metal					
	max. admissible pressures for GS3-valves in carbon steel						max. admissible pressures for GS3-valves in carbon steel					
	100°C	150°C	200°C	250°C	300°C	350°C	100°C	150°C	200°C	250°C	300°C	350°C
200 (max PN 25)	16	16	15	13	12	11	8	7	6	5	4	3
250 (max PN 25)	10	9	9	8	7	6	5,7	5,4	5,1	4,1	3,4	2,9

Limitation for SFC-sliding discs: 300°C

PN40

DN	Movable sealing disc carbon or SFC						Movable sealing disc STN2, STN3 or hard metal					
	max. admissible pressures for GS3-valves in carbon steel						max. admissible pressures for GS3-valves in carbon steel					
	100°C	150°C	200°C	250°C	300°C	350°C	100°C	150°C	200°C	250°C	300°C	350°C
15-50	40	40	40	40	40	40	40	40	40	40	40	40
65	40	40	40	40	40	40	40	40	40	37	32	32
80	40	40	40	40	40	40	36	34	33	26	22	19
100	33	33	33	33	33	33	33	31	30	24	20	17
125	23	23	23	23	23	23	22	21	19	16	13	11
150	16	16	16	16	16	16	16	15	14	11	9	8

Limitation for SFC-sliding discs: 300°C

PN100

DN	Movable sealing disc carbon or SFC						Movable sealing disc STN2, STN3 or hard metal					
	max. admissible pressures for GS3-valves in carbon steel						max. admissible pressures for GS3-valves in carbon steel					
	100°C	150°C	200°C	250°C	300°C	350°C	100°C	150°C	200°C	250°C	300°C	350°C
15 - 20	100	100	100	100	100	100	100	100	100	100	100	100
25	100	100	100	100	100	94	87	100	100	100	94	87
32	100	100	100	100	100	100	99	100	100	84	69	60
40	100	100	100	100	100	94	87	72	69	65	53	43
50	100	100	100	100	100	94	87	77	73	70	56	46
65	80	80	80	80	80	80	76	62	59	56	45	37
80	48	48	48	48	48	44	36	34	33	26	22	19

Limitation for SFC-sliding discs: 300°C

ANSI150

DN	Movable sealing disc carbon or SFC								Movable sealing disc STN2, STN3 or hard metal							
	max. admissible pressures for GS3-valves in carbon steel								max. admissible pressures for GS3-valves in carbon steel							
	38°C	50°C	100°C	150°C	200°C	250°C	300°C	350°C	38°C	50°C	100°C	150°C	200°C	250°C	300°C	350°C
15-125	19,6	19,2	17,7	15,8	13,8	12,1	10,2	8,4	19,6	19,2	17,7	15,8	13,8	12,1	10,2	8,4
150	16,0	16,0	16,0	15,8	13,8	12,1	10,2	8,4	16,2	16,2	16,2	15,4	13,8	11,8	9,7	8,0
200	16,0	16,0	16,0	15,8	13,8	12,1	10,2	8,4	10,5	10,0	8,3	7,6	6,9	5,5	4,5	3,9
250	10,5	10,5	10,5	9,9	9,4	8,4	7,4	6,0	5,7	5,7	5,7	5,4	5,1	4,1	3,4	2,6

Limitation for SFC-sliding discs: 300°C

ANSI300

DN	Movable sealing disc carbon or SFC								Movable sealing disc STN2, STN3 or hard metal							
	max. admissible pressures for GS3-valves in carbon steel								max. admissible pressures for GS3-valves in carbon steel							
	38°C	50°C	100°C	150°C	200°C	250°C	300°C	350°C	38°C	50°C	100°C	150°C	200°C	250°C	300°C	350°C
15-50	51,1	50,1	46,6	45,1	43,8	41,9	39,8	37,6	51,1	50,1	46,6	45,1	43,8	41,9	39,8	37,6
65	51,1	50,1	46,6	45,1	43,8	41,9	39,8	37,6	41,7	41,7	41,7	39,7	37,6	33,5	37,6	33,0
80	48,0	48,0	46,6	45,1	43,8	41,9	39,8	37,6	36,6	36,6	36,6	34,8	33,0	26,8	22,0	19,0
100	33,0	33,0	33,0	33,0	33,0	33,0	33,0	33,0	33,0	33,0	33,0	31,7	30,1	24,4	20,0	17,5
125	23,0	23,0	23,0	23,0	23,0	23,0	23,0	23,0	22,1	22,1	22,1	21,0	19,9	16,1	13,2	11,5
150	16,0	16,0	16,0	16,0	16,0	16,0	16,0	16,0	16,0	16,0	16,0	15,4	14,6	11,8	9,7	8,4
200	16,0	16,0	16,0	14,8	13,7	12,1	10,2	8,4	10,5	10,0	8,3	7,6	6,9	5,5	4,5	3,9

Limitation for SFC-sliding discs: 300°C

ANSI600

DN	Movable sealing disc carbon or SFC								Movable sealing disc STN2, STN3 or hard metal							
	max. admissible pressures for GS3-valves in carbon steel								max. admissible pressures for GS3-valves in carbon steel							
	38°C	50°C	100°C	150°C	200°C	250°C	300°C	350°C	38°C	50°C	100°C	150°C	200°C	250°C	300°C	350°C
15-25	102,1	100,2	93,2	90,2	87,6	83,9	79,6	75,1	102,1	100,2	93,2	90,2	87,6	83,9	79,6	75,1
32	102,1	100,2	93,2	90,2	87,6	83,9	79,6	75,1	102,1	100,2	93,2	90,2	87,6	83,9	69,6	60,0
40	100,0	100,0	93,2	90,2	87,6	83,9	79,6	75,1	72,5	72,5	72,5	69,0	65,5	53,1	43,6	37,0
50	100,0	100,0	93,2	90,2	87,6	83,9	79,6	75,1	77,7	77,7	77,7	73,9	70,2	56,9	46,7	40,0
65	80,0	80,0	80,0	80,0	80,0	80,0	79,6	75,1	62,5	62,5	62,5	59,5	56,4	45,8	37,6	32,0
80	48,0	48,0	48,0	48,0	48,0	48,0	48,0	44,0	36,6	36,6	36,6	36,8	33,0	26,8	22,0	19,0

Limitation for SFC-sliding discs: 300°C

Actuator (Type 2036) dimensions and weights

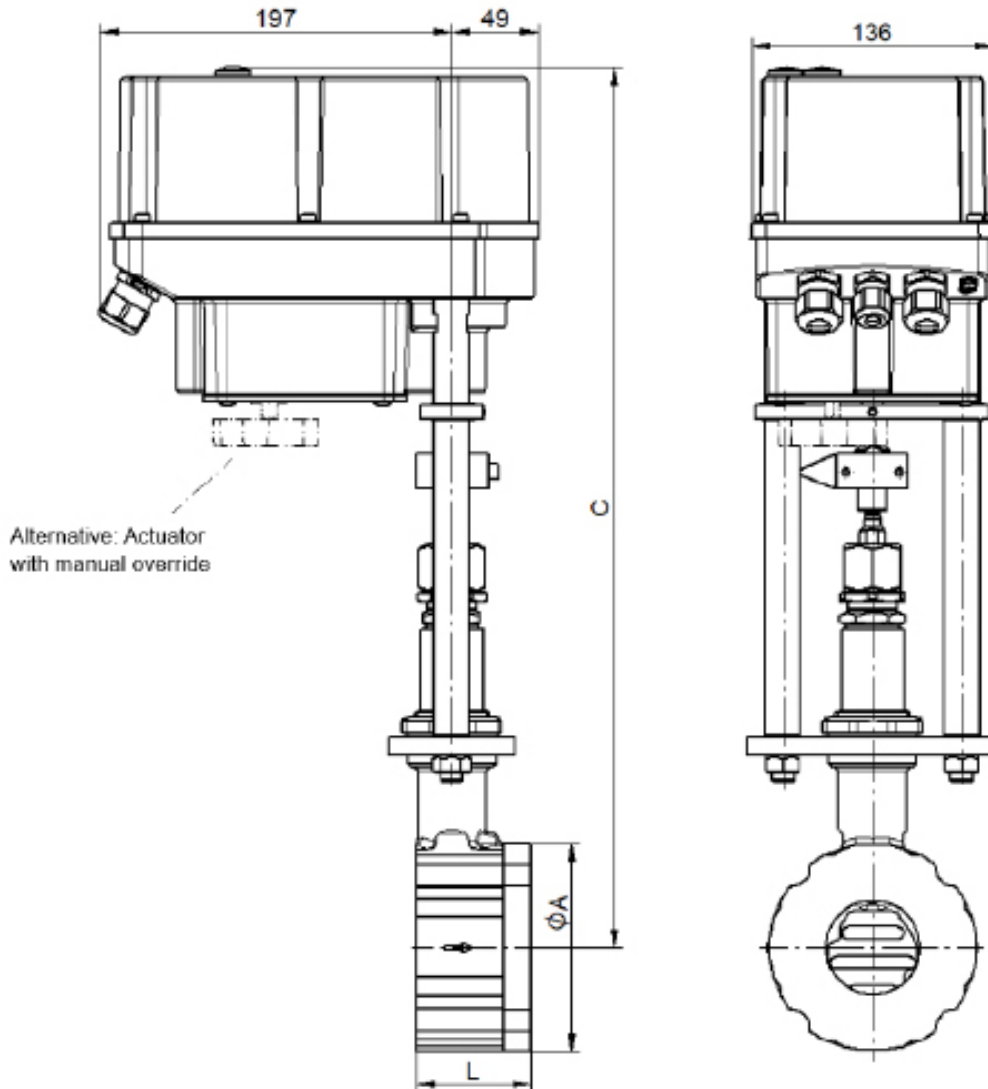

DN	ϕA	C	L	Stroke H	Weight kg
15	64	480	56	6,25	9,45
20	72	485	56	6,25	9,65
25	82	490	56	6,25	9,95
32	89	495	56	6,25	9,95
40	99	500	56	6,25	10,55
50	116	510	64	8,25	12,05
65	138	520	68	8,25	13,55
80	153	525	70	8,25	14,85
100	184	540	75	8,75	17,95
125	212	555	80	8,75	20,25
150	242	570	80	8,75	23,95
200	302	600	93	8,75	40,75
250	360	624	96	8,75	---

Dimensions in mm

Actuator (Type 2037) dimensions and weights

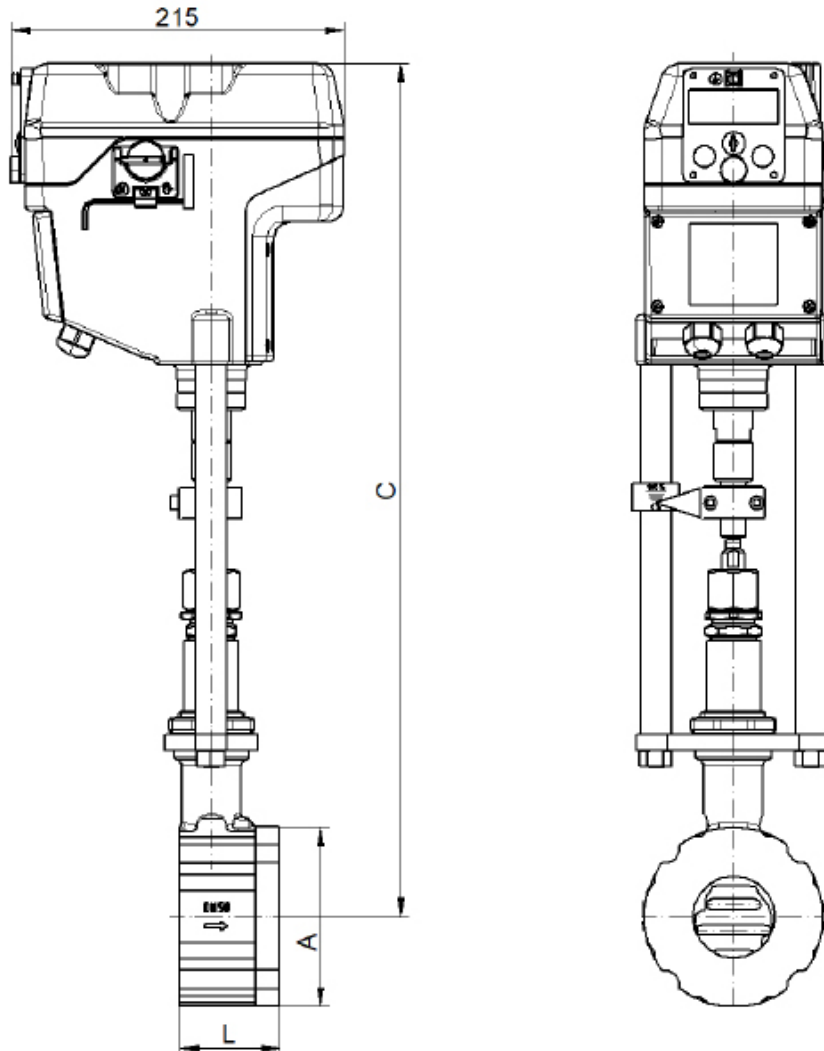

DN	øA	C	L	Stroke H	Weight kg
15	64	520	56	6,25	11,2
20	72	525	56	6,25	11,4
25	82	530	56	6,25	11,8
32	89	535	56	6,25	12,2
40	99	540	56	6,25	12,6
50	116	550	64	8,25	14,2
65	138	560	68	8,25	16,0
80	153	570	70	8,25	17,1
100	184	580	75	8,75	20,6
125	212	595	80	8,75	24,8
150	242	610	80	8,75	28,5
200	302	640	93	8,75	45,4
250	360	662	96	8,75	50,6

Dimensions in mm

Enquiry sheet for sliding gate valves

Valve dimensioning

In order to be able to dimension a valve for a quotation, at least the following data must be known:

1. Medium

(Designation, composition and aggregate state)

2. Operating data

		minimal	normal	maximum	units
Input pressure	P1				
Output pressure	P2				
Temperature	T1				
Flow rate	Q				

3. Valve function

Control valve

Stop valve

4. Type of actuator

Electrically operated Voltage V _____

Spring opens (NO)

Spring closes (NC)

5. Accessory

Limit switch Piece

Manual override with handwheel

6. Other requests