

Sliding Gate Motor Valve 8037



ex-version

GS 3 series, 1/2" up to 10"

Sliding gate motor valve for control and switching of neutral through to highly aggressive media in process engineering, chemical industries and for plant equipment, for applications in Ex-Zone 1, 2, 21 and 22.

Technical Information Valve

Body design	ANSI flange wafer (self-aligning) for flanges acc. ASME B16.5 RF or DIN EN 1092-1 Form B		
Nominal size	1/2" up to 10"		
Nominal pressure acc. DIN 2401	580 psi (fits also to 145-365 psi) 1450 psi 230 psi and 363 psi	1/2" - 6" 1/2" - 3" 8" - 10"	
Nominal pressure acc. ANSI	ANSI 150 ANSI 300 ANSI 600	1/2" - 10" 1/2" - 6" 1/2" - 3"	
Nominal pressure acc. JIS for raised face flanges	10K 20K	1/2" - 2" 1/2" - 1 1/2"	
Media temperature	Versions from -76°F up to +662°F		
Flange gaskets (customer side)	ANSI B16.21 or DIN EN 1514-1 in the respective nominal pressure rating		
Rangeability	30 : 1		
Leakage	Disc pair Carbon-stainless steel	Disc pair SFC	Disc pair STN 2
% of Kvs	< 0,0001	< 0,0005	< 0,001
IEC 60534-4	IV-S1	IV-S1	IV
EN 12266-1	E	F	F
Specific leakage rate shaft and body sealing	ISO FE-BH-CC3-SSA0-t(-40°C/+350°C)-PN40-ISO 15848-1		



* With DN15 with reduction of less than 25%, different leakage rates possible.
K_{vs} -values see data sheet 8001.

Technical Information Actuator

driving force	220 lbf, 550lbf, 1100 lbf
stroking speed	0.08 / 0.12 / 0.24 / 0.35 / 0.47 s/inch (adjustable)
power supply	24 ... 230 V AC/DC (longer range power supply)
input signal	3-point 4 - 20 mA or 0 - 10 V
feedback	4 - 20 mA or 0 - 10 V
explosion protection (gas)	II 2G Ex de [ia] IIC T6/T5
explosion protection (dust)	II 2D Ex tD [iaD] A21 IP66 T176°F
protection class	IP 66
ambient temperature	-4...+104°F at T6 / -4...+122°F at T5
operating mode	S3 / 50% ED (max. 600 switching cycle / h)
Hysteresis	ca. ±1.5%
resolution	ca. 100 steps
accommodation	self-learning
heating resistor element	16 Watt self actuating
motor	brushless DC motor
manual override	hexagon key (top of header)

Fluid temperature

Rating	PN40	PN 16	PN 100	ANSI 150	ANSI 300	ANSI 600
Body material cpl. stainless steel						
Tmin [°F]	-76	-76	-76	-20	-20	-20
Tmax [°F]	662	662	662	662	662	662
Body material carbon steel						
Tmin [°F]	-76	-76	14	-4	-4	-4
Tmax [°F]	662	662	662	662	662	662

Sliding Gate Motor Valve 8037-GS3



ex-version

Materials

Body	Stainless steel CF8M	Carbon steel ASTM A216 WCB	
Bodycover	Stainless steel 316Ti or 316L		
Bonnet	chrome plated brass (actuator ø 2", ø 3")		
	aluminium corrosion resistant coating (actuator ø 5")		
Springs	stainless steel 304 (actuator 2", 3")		
	spring steel wire C, coated (actuator 5")		
Packing	PTFE (carbon filled)		
Valve stem	stainless steel 316 Ti, roller burnished		
Bellows	stainless steel 316Ti		
Fixed plate	stainless steel 1.4571, plated	STN2-disc	
Sliding disc	standard:	SFC-disc	STN2-disc
	special carbon material		
Coupling ring for discs	stainless steel 318		

Stroking times for the complete stroke (sec.):

Speed	2	3	6	9	12
DN 1/2" - 1 1/2"	12.5	18.75	37.5	56.25	75
DN 2" - 3"	16.5	24.75	49.5	74.25	99
DN 4" - 10"	17.5	26.25	52.5	78.75	105

= factory setting

Admissible Pressures

(For temperatures of up to 100°F for ANSI-classes and up to 250°F for PN-classes)

For temperatures exceeding 100°F (ANSI) or 250°F (PN): consider operation limits

Size	220 lbf	550 lbf	1100 lbf	220 lbf	550 lbf	1100 lbf
	max. differential pressure (psi)			max. differential pressure (psi)		
	carbon/SFC - stainless steel coated			STN2		
1/2"	1280	1480	1480	910	1480	1480
3/4"	1110	1480	1480	700	1480	1480
1"	930	1276 (1480)*	1276 (1480)*	525	1276 (1395)*	1276 (1480)*
1 1/4"	765	1480	1480	390	1035	1480
1 1/2"	575	1276 (1450)*	1276 (1450)*	265	710	1055
2"	380	1010	1450	160	425	870
2 1/2"	320	850	1160	130	350	710
3"	205	540	695	80	210	430
4"	130	345	480	50	130	265
5"	90	235	335	35	85	180
6"	65	175	230	25	65	130
8"	40	100	205	13	36	75
10"	25	60	130	7	22	45

*: figures in brackets for bodys made of carbon steel

	Pressure limits ANSI and DIN in psi					
	ANSI150	ANSI 300	ANSI 600	PN16	PN40	PN100
P max. carbon steel	284	741	1480	232	580	1450
P max. stainless steel	276	719	1440			

Options

- 2 potential-free limit switches at a separated terminal box
- inductive proximity switches (mounted at the column)
- Version only for zone 2 and zone 22
- Version not ex-actuator

Sliding Gate Motor Valve 8037-GS3



ex-version

Ordering Number System

pos. 1 up to 4 please quote all 6 sections.
 pos. 5 up to 13 quote only if required.
 from pos. 14 if required, quoted by the manufacturer

Ordering	Num-ber:	1	2	3	4	5	6	7	8	9	10	11	12	13	14
8037/		H					M							Z	...
Nominal Size															
e.g. DN 1" = 025	xxx														
Article															
valve		V													
lower part		U													
repair-kit		R													
Function															
ex-proofed motor actuator (Type 8037)		H													
Body design															
GS3 - flangeless design acc. DIN, 145 psi - 580 psi, (DN200 235 psi)						G									
GS3 - flangeless design acc. DIN, 1450 psi						H									
GS3 - flangeless design, acc. ANSI 150						E									
GS3 - flangeless design, acc. ANSI 300						F									
Body material															
C-steel ASTM A216 WCB						0									
stainless steel CF8M						1									
Safety position															
without safety position						0									
Actuator															
without actuator						0									
220 lbf driving force, on /off, 3-point, IP66, 24...230V AC/DC, II 2GEx de [ia] IIC T5/T6						1									
550 lbf driving force, on /off, 3-point, IP66, 24...230V AC/DC, II 2GEx de [ia] IIC T5/T6						2									
1100 lbf driving force, on /off, 3-point, IP66, 24...230V AC/DC, II 2GEx de [ia] IIC T5/T6						3									
1 kN driving force with electronic positioner, IP66, 24...230V AC/DC, control signal 4-20mA/0-10V, feedback 4-20 mA/0-10V, II2G Ex de [ia] IIC T5/T6						A									
2,5 kN driving force with electronic positioner, IP66, 24...230V AC/DC, control signal 4-20mA/0-10V, feedback 4-20 mA/0-10V, II2G Ex de [ia] IIC T5/T6						B									
5 kN driving force with electronic positioner, IP66, 24...230V AC/DC, control signal 4-20mA/0-10V, feedback 4-20 mA/0-10V, II2G Ex de [ia] IIC T5/T6						C									
Motor voltage															
24...230V AC/DC (standard)							-								
Stem sealing															
standard (PTFE-V-shaped seal, self-adjusting)								-							
additional stainless steel bellows								1							
Sliding disc															
carbon steel									-						
STN2/STN3									9						
SFC									S						
Fixed disc															
standard coated, stainless steel 316 Ti										-					
STN2										1					
STN3										2					
Cv-value															
100% (standard)													-		
red. 63%													A		
red. 40%													1		
red. 25%													B		
red. 16%													2		
red. 10%													C		
further reductions on request (see data sheet 8001)													...		
Seat characteristics															
linear														-	
equal percentage														1	
Accessories															
please note															Z

pos. 1 up to 4 please quote all 6 sections.
 pos. 5 up to 13 quote only if required.
 from pos. 14 if required, quoted by the manufacturer

On request further versions are possible!

ex-version

Application limitations for GS3 valves in stainless steel

These pressure must not be exceeded for GS-valves from the GS3-series made of stainless steel, even though the actuator power might allow it.

ANSI150

Size	Sliding unit: carbon/SFC - stainless steel, coated								Sliding unit: STN2							
	max. admissible pressures for GS3-valves in stainless steel								max. admissible pressures for GS3-valves in stainless steel							
	100°F	120°F	210°F	300°F	390°F	480°F	570°F	660°F	100°F	120°F	210°F	300°F	390°F	480°F	570°F	660°F
1/2" - 5"	275	265	235	215	200	175	150	120	275	265	235	215	200	175	150	120
6"	230	230	230	215	200	175	150	120	235	235	235	215	200	170	140	120
8"	230	230	230	215	200	175	150	120	150	145	120	110	100	80	65	55
10"	150	150	150	145	135	120	105	100	85	85	85	80	75	60	50	40

Limitation for SFC-sliding discs: 570°F

ANSI300

Size	Sliding unit: carbon/SFC - stainless steel, coated								Sliding unit: STN2							
	max. admissible pressures for GS3-valves in stainless steel								max. admissible pressures for GS3-valves in stainless steel							
	100°F	120°F	210°F	300°F	390°F	480°F	570°F	660°F	100°F	120°F	210°F	300°F	390°F	480°F	570°F	660°F
1/2" - 2 1/2"	720	695	610	560	520	485	460	440	720	695	610	560	520	485	460	440
3"	695	695	610	560	520	485	460	440	530	530	530	505	480	390	320	275
4"	480	480	480	480	480	480	460	440	480	480	480	460	435	355	290	250
5"	335	335	335	335	335	335	335	335	320	320	320	305	290	235	190	165
6"	230	230	230	230	230	230	230	230	230	230	230	225	210	170	140	120
8"	230	230	230	145	135	120	105	100	230	230	220	200	180	155	140	130

Limitation for SFC-sliding discs: 570°F

ANSI600

Size	Sliding unit: carbon/SFC - stainless steel, coated								Sliding unit: STN2							
	max. admissible pressures for GS3-valves in stainless steel								max. admissible pressures for GS3-valves in stainless steel							
	100°F	120°F	210°F	300°F	390°F	480°F	570°F	660°F	100°F	120°F	210°F	300°F	390°F	480°F	570°F	660°F
1/2" - 3/4"	1440	1395	1225	1115	1035	970	915	880	1440	1395	1225	1115	1035	970	915	880
1"	1275	1275	1225	1115	1015	925	830	785	1275	1275	1225	1115	1015	925	830	785
1 1/4"	1440	1395	1225	1115	1035	970	915	880	1440	1395	1225	1115	1035	970	915	875
1 1/2"	1275	1275	1225	1115	1015	925	830	785	1050	1050	1050	1000	950	770	630	545
2"	1440	1395	1225	1115	1035	970	915	880	1125	1125	1125	1070	1020	825	675	585
2 1/2"	1160	1160	1160	1115	1035	970	915	880	905	905	605	865	820	665	545	470
3"	695	695	695	695	695	695	695	645	530	530	530	505	480	390	320	275

Limitation for SFC-sliding discs: 570°F

PN40

Size	Sliding unit: carbon/SFC - stainless steel, coated							Paarung: STN 2						
	maximum pressures for GS3-valves in stainless steel							maximum pressures for GS3-valves in stainless steel						
	210°F	300°F	390°F	480°F	570°F	660°F	210°F	300°F	390°F	480°F	570°F	660°F		
1/2"-1 1/4"	580	580	580	580	580	580	580	580	580	580	580	580		
1 1/2"	580	580	580	580	580	580	580	580	580	580	580	535		
2"	580	580	580	580	580	580	580	580	580	580	580	580		
2 1/2"	580	580	580	580	580	580	580	580	580	580	535	465		
3"	580	580	580	580	580	580	520	495	480	375	320	275		
4"	480	480	480	480	480	480	465	450	435	350	290	245		
5"	335	335	335	335	335	335	305	305	275	230	190	160		
6"	230	230	230	230	230	230	220	220	205	160	130	115		
8" (only PN16)	230	230	220	190	175	160	120	110	100	80	65	55		
10" (only PN16)	145	130	130	115	100	85	85	80	75	60	50	40		

Limitation for SFC-sliding discs: 570°F

PN100

Size	Sliding unit: carbon/SFC - stainless steel, coated						Paarung: STN 2					
	maximum pressures for GS3-valves in stainless steel						maximum pressures for GS3-valves in stainless steel					
	210°F	300°F	390°F	480°F	570°F	660°F	210°F	300°F	390°F	480°F	570°F	660°F
1/2"	1450	1450	1450	1350	1220	1145	1450	1450	1450	1350	1220	1145
3/4"	1450	1450	1290	1175	1060	985	1450	1450	1290	1175	1060	985
1"	1275	1175	1015	915	825	785	1275	1175	1015	915	825	785
1 1/4"	1450	1350	1160	1060	945	900	1450	1350	1160	1060	945	870
1 1/2"	1275	1175	1015	915	825	785	1045	1000	945	770	625	535
2"	1450	1450	1450	1450	1450	1365	1115	1060	1015	810	665	580
2 1/2"	1160	1160	1160	1145	1030	970	900	855	810	655	535	465
3"	695	695	695	695	695	640	520	495	480	375	320	275

Limitation for SFC-sliding discs: 570°F

ex-version

Application limitations for GS3 valves in carbon steel

These pressure must not be exceeded for GS-valves from the GS3-series made of carbon steel, even though the actuator power might allow it.

ANSI150

Size	Sliding unit: carbon/SFC - stainless steel, coated								Sliding unit: STN2							
	max. admissible pressures for GS3-valves in carbon steel								max. admissible pressures for GS3-valves in carbon steel							
	100°F	120°F	210°F	300°F	390°F	480°F	570°F	660°F	100°F	120°F	210°F	300°F	390°F	480°F	570°F	660°F
1/2"-5"	285	280	255	230	200	175	150	120	285	280	255	230	200	175	150	120
6"	230	230	230	230	200	175	150	120	235	235	235	225	200	170	140	115
8"	230	230	230	230	200	175	150	120	150	145	120	110	100	80	65	55
10"	150	150	150	145	135	120	105	87	85	85	85	80	75	60	50	40

Limitation for SFC-sliding discs: 570°F

ANSI300

Size	Sliding unit: carbon/SFC - stainless steel, coated								Sliding unit: STN2							
	max. admissible pressures for GS3-valves in carbon steel								max. admissible pressures for GS3-valves in carbon steel							
	100°F	120°F	210°F	300°F	390°F	480°F	570°F	660°F	100°F	120°F	210°F	300°F	390°F	480°F	570°F	660°F
1/2"-2"	740	725	675	655	635	610	565	535	740	725	675	655	635	610	565	535
2 1/2"	740	725	675	655	635	610	565	535	605	605	605	575	545	485	550	470
3"	695	695	675	655	635	610	565	535	530	530	530	505	480	390	319	275
4"	480	480	480	480	480	480	475	475	480	480	480	460	435	355	290	245
5"	335	335	335	335	335	335	330	330	320	320	320	305	290	235	191	155
6"	230	230	230	230	230	230	230	230	230	230	230	225	210	170	141	115
8"	230	230	220	200	180	155	140	130	150	145	120	110	100	65	65	55

Limitation for SFC-sliding discs: 570°F

ANSI600

Size	Sliding unit: carbon/SFC - stainless steel, coated								Sliding unit: STN2							
	max. admissible pressures for GS3-valves in carbon steel								max. admissible pressures for GS3-valves in carbon steel							
	100°F	120°F	210°F	300°F	390°F	480°F	570°F	660°F	100°F	120°F	210°F	300°F	390°F	480°F	570°F	660°F
1/2"-1"	1480	1455	1350	1310	1270	1215	1155	1085	1480	1455	1350	1310	1270	1215	1155	1085
1 1/4"	1480	1455	1350	1310	1270	1215	1155	1085	1480	1455	1350	1310	1270	1215	1010	870
1 1/2"	1450	1450	1350	1310	1270	1215	1155	1085	1050	1050	1050	1000	950	770	630	535
2"	1450	1450	1350	1310	1270	1215	1155	1085	1125	1125	1125	1070	1020	825	675	580
2 1/2"	1160	1160	1160	1160	1160	1160	1155	1085	905	905	905	865	820	665	545	460
3"	695	695	695	695	695	695	695	635	530	530	530	535	480	390	320	275

Limitation for SFC-sliding discs: 570°F

PN40

Size	Sliding unit: carbon/SFC - stainless steel, coated							Sliding unit: STN2						
	max. admissible pressures for GS3-valves in carbon steel							max. admissible pressures for GS3-valves in carbon steel						
	210°F	300°F	390°F	480°F	570°F	660°F	210°F	300°F	390°F	480°F	570°F	660°F		
1/2" - 2"	580	580	580	580	580	580	580	580	580	580	580	580		
2 1/2"	580	580	580	580	580	580	580	580	580	580	535	460		
3"	580	580	580	580	580	580	520	495	480	375	320	275		
4"	480	480	480	480	480	475	480	450	435	350	290	245		
5"	335	335	335	335	335	330	320	305	275	230	190	155		
6"	230	230	230	230	230	230	230	220	205	160	130	115		
8" (max 365 psi)	230	230	220	190	175	155	120	110	100	80	65	55		
10" (max 365 psi)	145	130	130	115	100	87	85	80	75	60	50	40		

Limitation for SFC-sliding discs: 570°F

PN100

Size	Sliding unit: carbon/SFC - stainless steel, coated						Sliding unit: STN2					
	max. admissible pressures for GS3-valves in carbon steel						max. admissible pressures for GS3-valves in carbon steel					
	210°F	300°F	390°F	480°F	570°F	660°F	210°F	300°F	390°F	480°F	570°F	660°F
1/2" - 3/4"	1450	1450	1450	1450	1450	1450	1450	1450	1450	1450	1450	1450
1"	1450	1450	1450	1450	1365	1260	1450	1450	1450	1450	1365	1260
1 1/4"	1450	1450	1450	1450	1450	1435	1450	1450	1450	1220	1000	870
1 1/2"	1450	1450	1450	1450	1365	1260	1045	1000	945	770	625	535
2"	1450	1450	1450	1450	1450	1360	1115	1060	1015	810	665	580
2 1/2"	1160	1160	1160	1160	1160	1100	900	855	810	655	535	460
3"	695	695	695	695	695	635	520	495	480	375	320	275

Limitation for SFC-sliding discs: 570°F

Sliding Gate Motor Valve 8037-GS3



ex-version

Dimensions and Weights

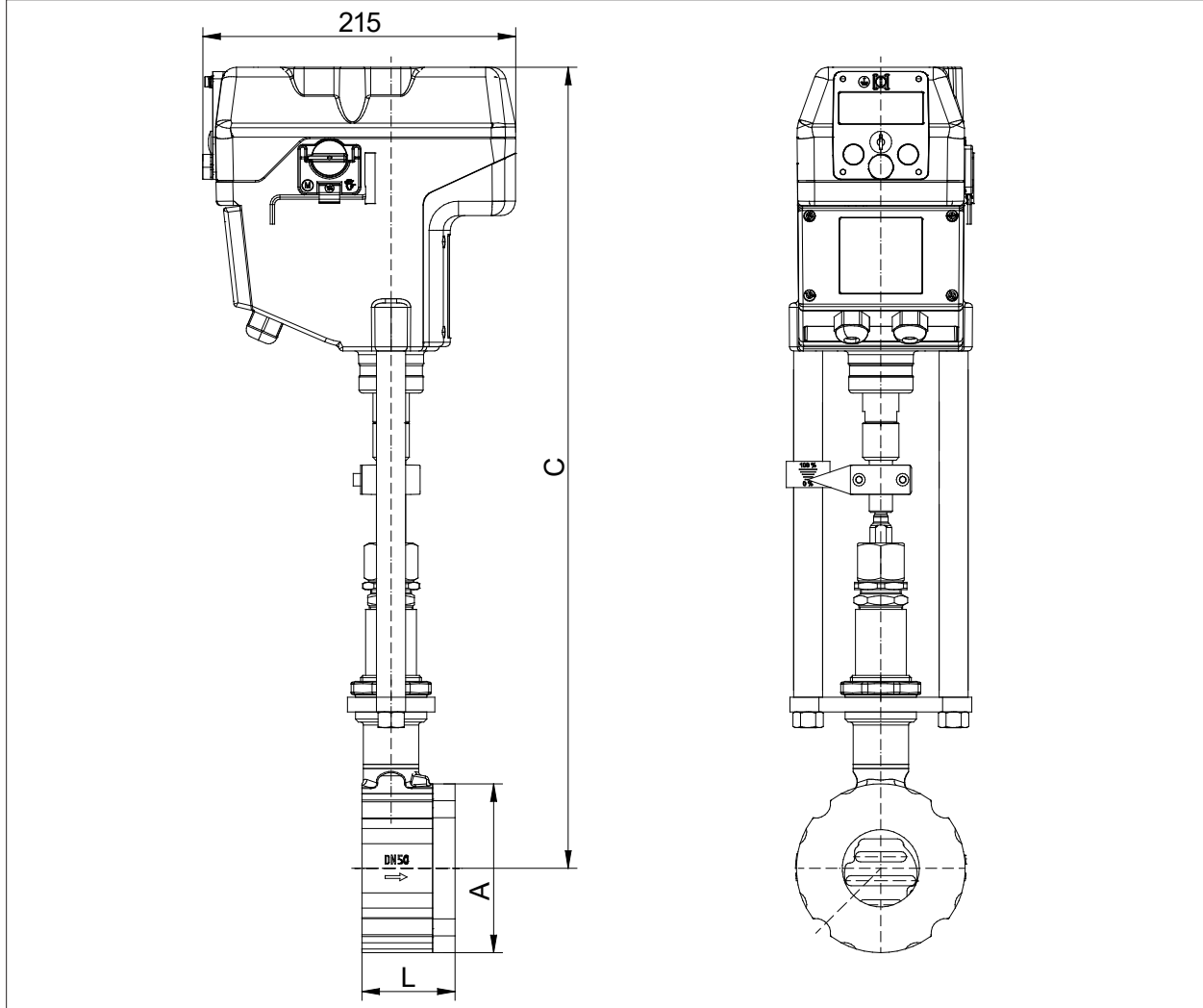

Size	A	C	L	Weight (lbs)	Stroke
1/2"	2.5	20.45	2.2	24.5	0.24
3/4"	2.85	20.65	2.2	25	0.24
1"	3.25	20.85	2.2	26	0.24
1 1/4"	3.5	21.05	2.2	27	0.24
1 1/2"	3.9	21.25	2.2	28	0.24
2"	4.55	21.65	2.5	31.5	0.31
2 1/2"	5.45	22.05	2.7	35.5	0.31
3"	6	22.45	2.75	37.5	0.31
4"	7.25	22.85	2.95	45.5	0.33
5"	8.35	23.45	3.15	54.5	0.33
6"	9.55	24	3.15	62.5	0.33
8"	11.9	25.2	3.65	100	0.35
10"	14.15	26.05	3.8	111.5	0.35

Dimensions in inch

Sliding Gate Motor Valve 8037-GS3



Flow Coefficients - Cv-values

Ordering code	-	A	1	B	6	2	7	C	3	4	8	5	9	
Size	Charact.	100 %	63 %	40 %	25 %	20%	16 %	12 %	10 %	6,3 %	2,5 %	2 %	1 %	0,4%
1/2"	(mod.) linear	4.6	3	2	1.6	-	0.82	0.57	0.51	0.3	0.16	0.09	0.05	0.021
	eq. perc.	2	-	1.3	-	0.4	-	-	-	0.12	-	-	-	-
3/4"	(mod.) lin.	7.4	-	-	-	-	1.16	-	-	-	-	0.15	-	-
	eq. perc.	3.5	-	1.7	-	-	-	-	-	-	-	-	-	-
1"	(mod.) linear	13	7.4	4.6	-	-	1.9	-	1.08	0.72	0.3	-	0.16	0.05
	eq. perc.	5.8	-	2.8	-	1.3	-	-	-	0.41	-	-	-	-
1 1/4"	(mod.) linear	19	12	-	-	-	-	-	-	-	-	-	-	-
	eq. perc.	9.3	5.45	-	-	-	-	-	-	-	-	-	-	-
1 1/2"	(mod.) lin.	30	19	13	8.1	-	-	-	-	-	-	-	-	-
	eq. perc.	13	9.9	-	3.2	-	-	-	-	-	-	-	-	-
2"	(mod.) linear	52	32	23	14	12	-	-	-	-	-	-	-	-
	eq. perc.	22	14	-	-	-	-	3.5	-	-	-	-	-	-
2 1/2"	(mod.) linear	60	41	-	17	-	-	-	-	-	-	-	-	-
	eq. perc.	35	-	-	9.3	-	-	-	-	-	-	-	-	-
3"	(mod.) linear	107	67	46	-	-	-	-	-	-	-	-	-	-
	eq.perc.	56	41	-	-	-	-	-	-	-	-	-	-	-
4"	(mod.) linear	179	110	72	-	-	-	-	-	-	-	-	-	-
	eq.perc.	89	56	-	-	-	-	-	-	-	-	-	-	-
5"	(mod.) linear	275	-	110	-	-	-	-	-	-	-	-	-	-
	eq.perc.	135	-	-	-	-	-	-	-	-	-	-	-	-
6"	(mod.) linear	392	246	-	-	-	-	-	-	-	-	-	-	-
	eq.perc.	171	104	-	-	-	-	-	-	-	-	-	-	-
8"	(mod.) linear	650	408	-	-	-	-	-	-	-	-	-	-	-
	eq.perc.	329	-	-	-	-	-	-	-	-	-	-	-	-
10"	(mod.) linear	1056	667	-	-	-	-	-	-	-	-	-	-	-
	eq.perc.	-	-	-	-	-	-	-	-	-	-	-	-	-