

GS 3 series, DN 15 up to DN 250

Sliding gate motor valve for control and switching of neutral through to highly aggressive media in process engineering, chemical industries and for plant equipment.

- Space saving wafer type construction
- Lowest possible weight (especially in larger sizes)
- Low operation noise level (quiet operation)
- Control of high differential pressures with small actuators
- Fast response time
- Meets the requirements of TA-Luft 2021



Technical Information

Design	wafer-type design for flanges acc. DIN EN 1092-1 Form B or ASME B16.5 RF further versions see data sheet 8030-GS1		
Nominal size	DN 15 up to DN 250		
Nominal pressure acc. DIN 2401 for flanges with facing type B	PN 40 (fits also to PN 10-25) PN 100 PN 16 and PN 25	DN 15 - DN 150 DN 15 - DN 80 DN 200 - DN 250	
Nominal pressure acc. ANSI for flanges acc. ASME B16.5 RF	ANSI 150 ANSI 300 ANSI 600	DN15 - DN 250 DN 15 - DN 150 DN 15 - DN 80	
Nominal pressure acc. JIS for „raiced face“ flanges	10K 20K	DN 15 - DN 50 DN 15 - DN 40	
Media temperature	Versions from -60°C up to +350°C		
Flange gaskets (customer side)	DIN EN 1514-1 or ANSI B16.21 in the respective nominal pressure rating		
Rangeability	30 : 1		
Leakage	Disc pair Carbon-stainless steel	Disc pair SFC	Disc pair STN 2
% of Kvs IEC 60534-4 EN122661	<0,0001 IV-S1 E < 0,0001 IV-S1 D	<0,0005 IV-S1 F < 0,0005 IV-S1 E	<0,001 IV F < 0,001 IV E
Spezific leakage rate shaft and body sealing	ISO FE-BH-CC3-SSA0-t(-40°C/+350°C)-PN40-ISO 15848-1		

* With DN15 with reduction of less than 25%, different leakage rates possible.
K_{vs}-values see data sheet 8001.

Fluid temperature

Rating	PN40	PN 16	PN 100	ANSI 150	ANSI 300	ANSI 600
Body material cpl. stainless steel						
Tmin [°C]	-60	-60	-60	-29	-29	-29
Tmax [°C]	350	350	350	350	350	350
Body material cpl. carbon steel						
Tmin [°C]	-60	-60	-10	-20	-20	-10
Tmax [°C]	300	300	300	300	300	300

Materials

Body	Stainless steel 1.4408	Carbon steel 1.0619
Bodycover	Stainless steel 1.4404 or 316L	
Packing	PTFE (carbon filled), spring 1.4310	
Actuating stem	Stainless steel, roller burnished	
Bellow	Stainless steel 1.4571	
Fixed plate	Stainless steel 1.4571, plated	STN2-disc
Sliding disc	Standard: special carbon material	SFC-disc STN2-disc
Coupling ring for discs	Stainless steel 1.4581	

Stroking times (sec.):

Driving force	0,9 kN	2,0 kN	4,5 kN
Stroking speed mm/min	10	9,2	24
DN 15 - 40	36	39	15
DN 50 - 80	47	52	20
DN 100 - 150	50	55	21

Power consumption (Watt):

24 VAC, 230 VAC	5	6,6	40/28
24 VDC	10	20	30
400 V, 50 Hz	10	10	35
110/120 V AC	5	6,6	28

Options

Limit switches	max. 2	max. 2	max. 2
Potentiometer	1	1	max. 2*
Positioner, analogue	yes	yes	yes

* One potentiometer is required for positioner option

Technical Information for the motor actuator

Driving force	0,9 kN; 2 kN; 4,5 kN
Type of duty (according VDE 0530)	S 1 - 100 % ED (0,9 kN; 2 kN; 4,5 kN DC) S 4 - 30 % ED 600c/h (0,9 kN; 2 kN) S 4 - 30 % ED 600c/h (4,5 kN)
Power connections	24 V AC, 24 V DC 110/120V AC 230 V AC 400 V 3-phase-AC other on request
Ambient temperature	0°C up to +60°C; -20°C bis +60°C with heating resistor element
Mounting position	free choice, but motor not vertical down
Protection class (Din 40050)	IP 65

Additional stroking times

Actuator (kN)	0,9				2		4,5	
	13,5	8	5,1	2,9	15,2	7,5	5,6	50
Stroking speed mm/min.								
Nominal size	Stroking times (sec.)							
DN 15 - 40	28	47	74	129	25	50	67	7,5
DN 50 - 80	37	62	97	171	33	66	88	9,9
DN 100-250	39	66	103	181	35	70	94	10,5

Admissible differential pressures (For temperatures of up to 120°C with PN-rating up to 38°C with ANSI-rating)

**For temperatures of 120°C (PN) or
38°C (ANSI) and above:
obey application limits !**

DN	0,9 kN	2,0 kN	4,5 kN	0,9 kN	2,0 kN	4,5 kN
	maximum differential pressure (bar)			maximum differential pressure (bar)		
	Disc pair carbon/SFC - stainless steel coated			STN2-disc pair		
15	78,5	102,1	102,1	55,7	102,1	102,1
20	68,1	102,1	102,1	42,9	101,9	102,1
25	57,1	88 (102,1)*	88 (102,1)*	32,1	76,1	88 (102,1)*
32	46,8	102,1	102,1	23,8	56,6	102,1
40	35,4	84	88 (100)*	16,4	38,9	72,6
50	23,2	55,1	100	9,8	23,2	53,8
65	19,5	46,4	80	8	19	44,1
80	12,4	29,5	48	4,9	11,5	26,7
100	7,9	18,8	33	3	7,1	16,5
125	5,4	12,8	23	2	4,8	11
150	4	9,5	16	1,5	3,5	8,2
200	2,3	5,5	12,8	0,8	2,1	4,6
250	1,4	3,4	7,9	0,5	1,2	2,8

*figures in brackets for bodys of carbon steel

	Upper limits for admissible pressures in bar					
	PN16	PN40	PN100	ANSI150	ANSI 300	ANSI 600
P max. carbon steel	16	40	100	19,6	51,1	102,1
P max. stainless steel				19,0	49,6	99,3

Ordering Number System

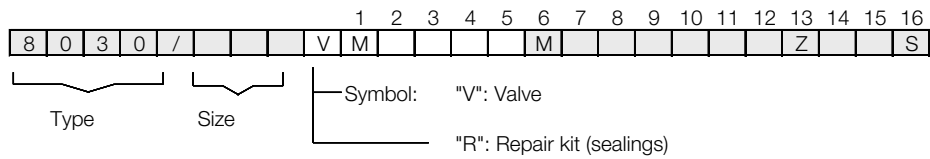

1 - 5 : Please quote all 5 sections.
 6 - 16: Quote only if required.

1. Function	2. Body design	3. Body material	4. Safety position	5. Actuator	6. Special versions	7. Motor voltages
M Control valve with motor actuator (type 8030)	E GS3 - flangeless design acc. ANSI 150 F GS3 - flangeless design acc. ANSI 300 K GS3 - flangeless design acc. ANSI 600 G GS3 - flangeless design acc. DIN, PN10-PN40 H GS3 - flangeless design acc. DIN, PN100	0 carbon steel 1.0619 1 stainless steel 1.4408	- without	4 0,9 kN - IP65 1 2,0 kN - IP65 2 4,5 kN - IP65	M To state, if further sections are quoted A groove and groove acc. DIN EN1092-1 C groove and tongue acc. DIN EN1092-1 E 2x lowered face acc. DIN EN1092-1 H lowered and raised face acc. DIN EN1092-1	- 230 V AC (Standard) 1 24 V AC 2 400 V, 50 Hz rotary current 3 24 V DC 4 110/120V AC
8. Stem sealing	9. Sliding disc	10. Fixed disc	11. Kvs-values	12. Flow characteristic	13. Accessories	14. Limit switches
- PTFE-V-shaped seal, self-adjusting (Standard) 1 additional stainless steel bellows 1.4571	- carbon material 9 STN2 S SFC	- stainless steel 1.4581, hard-chrome plated 1 STN2 (only in combination with the position „9“ STN2-disc)	- 100 % (Stand.) A red. to 63 % 1 red. to 40 % B red. to 25% 2 red. to 16 % C red. to 10% 3 red. to 6.3 % 4 red. to 2.5 % 5 red. to 1 % 6 red. to 20% 7 red. to 2% 8 red. to 20% 9 red. to 0,4%	- linear equal percentage 1	Z To state, if further sections are quoted	- without one limit switch 1 2 two limit switches
15. Feedback	16. Special versions	17. Options	18. Special treatment	19. Positioner		
- without potentiometer 1 1000 Ohm stroke feedback for positioner C 0/4 - 20mA	S Quote for further special versions	- Standard	- Standard	- without positioner 3 positioner 0-10 V N positioner 4-20 mA M positioner 0-20 mA		

Ordering example: 8030/100VMG10-1M1 - - - - - Z2
 GS3-control valve with motor actuator, DN 100, PN 10/40, stainless steel, actuator 2 kN, 24 V AC, PTFE-Packing, carbon-stainless steel 1.4571 coated, linear characteristics, 2 stroke dependent limit switches

Application limitations for GS3 valves in stainless steel

These pressures must not be exceeded for GS-valves from the GS3-series made of stainless steel, even though the actuator power might allow it.

PN40

DN	Sliding unit: carbon/SFC - stainless steel, coated						Sliding unit: STN2					
	max. admissible pressures for GS3-valves in stainless steel						max. admissible pressures for GS3-valves in stainless steel					
	100°C	150°C	200°C	250°C	300°C	350°C	100°C	150°C	200°C	250°C	300°C	350°C
15-32	40	40	40	40	40	40	40	40	40	40	40	40
40	40	40	40	40	40	40	40	40	40	40	40	37
50	40	40	40	40	40	40	40	40	40	40	40	40
65	40	40	40	40	40	40	40	40	40	40	37	32
80	40	40	40	40	40	40	36	34	33	26	22	19
100	33	33	33	33	33	33	32	31	30	24	20	17
125	23	23	23	23	23	23	21	21	19	16	13	11
150	16	16	16	16	16	16	15	15	14	11	9	8
200 (max. PN25)	16	16	15	13	12	11	8	7	6	5	4	3
250 (max. PN25)	10	9	9	8	7	6	5,7	5,4	5,1	4,1	3,4	2,9

Limitation for SFC-sliding discs: 300°C

PN100

DN	Sliding unit: carbon/SFC - stainless steel, coated						Sliding unit: STN2					
	max. admissible pressures for GS3-valves in stainless steel						max. admissible pressures for GS3-valves in stainless steel					
	100°C	150°C	200°C	250°C	300°C	350°C	100°C	150°C	200°C	250°C	300°C	350°C
15	100	100	100	93	84	79	100	100	100	93	84	79
20	100	100	89	81	73	68	100	100	89	81	73	68
25	88	81	70	63	57	54	88	81	70	63	57	54
32	100	93	80	73	65	62	100	93	80	73	65	60
40	88	81	70	63	57	54	72	69	65	53	43	37
50	100	100	100	100	100	94	77	73	70	56	46	40
65	80	80	80	79	71	67	62	59	56	45	37	32
80	48	48	48	48	48	44	36	34	33	26	22	19

Limitation for SFC-sliding discs: 300°C

ANSI150

DN	Sliding unit: carbon/SFC - stainless steel, coated								Sliding unit: STN2							
	max. admissible pressures for GS3-valves in stainless steel								max. admissible pressures for GS3-valves in stainless steel							
	38°C	50°C	100°C	150°C	200°C	250°C	300°C	350°C	38°C	50°C	100°C	150°C	200°C	250°C	300°C	350°C
15-125	19,0	18,4	16,2	14,8	13,7	12,1	10,2	8,4	19,0	18,4	16,2	14,8	13,7	12,1	10,2	8,4
150	16,0	16,0	16,0	14,8	13,7	12,1	10,2	8,4	16,2	16,2	16,2	14,8	13,7	11,8	9,7	8,4
200	16,0	16,0	16,0	14,8	13,7	12,1	10,2	8,4	10,5	10,0	8,3	7,6	6,9	5,5	4,5	3,9
250	10,4	10,4	10,4	9,9	9,4	8,4	7,4	6,8	5,7	5,7	5,7	5,4	5,1	4,1	3,4	2,6

Limitation for SFC-sliding discs: 300°C

ANSI300

DN	Sliding unit: carbon/SFC - stainless steel, coated								Sliding unit: STN2							
	max. admissible pressures for GS3-valves in stainless steel								max. admissible pressures for GS3-valves in stainless steel							
	38°C	50°C	100°C	150°C	200°C	250°C	300°C	350°C	38°C	50°C	100°C	150°C	200°C	250°C	300°C	350°C
15-65	49,6	48,1	42,2	38,5	35,7	33,4	31,6	30,3	49,6	48,1	42,2	38,5	35,7	33,4	31,6	30,3
80	48,0	48,0	42,2	38,5	35,7	33,4	31,6	30,3	36,6	36,6	36,6	34,8	33,0	26,8	22,0	19,0
100	33,0	33,0	33,0	33,0	33,0	33,0	31,6	30,3	33,0	33,0	33,0	31,7	30,1	24,4	20,1	17,3
125	23,0	23,0	23,0	23,0	23,0	23,0	23,0	23,0	22,0	22,0	22,0	21,0	19,9	16,1	13,2	11,5
150	16,0	16,0	16,0	16,0	16,0	16,0	16,0	16,0	16,0	16,0	16,0	15,4	14,6	11,8	9,7	8,4
200	16,0	16,0	16,0	14,8	13,7	12,1	10,2	8,4	10,5	10,0	8,3	7,6	6,9	5,5	4,5	3,9

Limitation for SFC-sliding discs: 300°C

ANSI600

DN	Sliding unit: carbon/SFC - stainless steel, coated								Sliding unit: STN2							
	max. admissible pressures for GS3-valves in stainless steel								max. admissible pressures for GS3-valves in stainless steel							
	38°C	50°C	100°C	150°C	200°C	250°C	300°C	350°C	38°C	50°C	100°C	150°C	200°C	250°C	300°C	350°C
15-20	99,3	96,2	84,4	77,0	71,3	66,8	63,2	60,7	99,3	96,2	84,4	77,0	71,3	66,8	63,2	60,7
25	88,0	88,0	84,4	77,0	70,1	63,7	57,3	54,2	88,0	88,0	84,4	77,0	70,1	63,7	57,3	54,2
32	99,3	96,2	84,4	77,0	71,3	66,8	63,2	60,7	99,3	96,2	84,4	77,0	71,3	66,8	63,2	60,2
40	88,0	88,0	84,4	77,0	70,1	63,7	57,3	54,2	72,5	72,5	72,5	69,0	65,5	53,1	43,6	37,7
50	99,3	96,2	84,4	77,0	71,3	66,8	63,2	60,7	77,7	77,7	77,7	73,9	70,2	56,9	46,7	40,4
65	80,0	80,0	80,0	77,0	71,3	66,8	63,2	60,7	62,5	62,5	41,7	59,5	56,4	45,8	37,6	32,5
80	48,0	48,0	48,0	48,0	48,0	48,0	48,0	44,5	36,6	36,6	36,6	34,8	33,0	26,8	22,0	19,0

Limitation for SFC-sliding discs: 300°C

Application limitations for GS3 valves in carbon steel

These pressure must not be exceeded for GS-valves from the GS3-series made of carbon steel, even though the actuator power might allow it.

PN40

DN	Sliding unit: carbon/SFC - stainless steel, coated						Sliding unit: STN2					
	max. admissible pressures for GS3-valves in carbon steel						max. admissible pressures for GS3-valves in carbon steel					
	100°C	150°C	200°C	250°C	300°C	350°C	100°C	150°C	200°C	250°C	300°C	350°C
15-50	40	40	40	40	40	40	40	40	40	40	40	40
65	40	40	40	40	40	40	40	40	40	37	32	
80	40	40	40	40	40	40	36	34	33	26	22	19
100	33	33	33	33	33	33	33	31	30	24	20	17
125	23	23	23	23	23	23	22	21	19	16	13	11
150	16	16	16	16	16	16	16	15	14	11	9	8
200 (max PN 25)	16	16	15	13	12	11	8	7	6	5	4	3
250 (max PN 25)	10	9	9	8	7	6	5,7	5,4	5,1	4,1	3,4	2,9

Limitation for SFC-sliding discs: 300°C

PN100

DN	Sliding unit: carbon/SFC - stainless steel, coated						Sliding unit: STN2					
	max. admissible pressures for GS3-valves in carbon steel						max. admissible pressures for GS3-valves in carbon steel					
	100°C	150°C	200°C	250°C	300°C	350°C	100°C	150°C	200°C	250°C	300°C	350°C
15 - 20	100	100	100	100	100	100	100	100	100	100	100	100
25	100	100	100	100	100	94	100	100	100	94	87	
32	100	100	100	100	100	100	100	100	84	69	60	
40	100	100	100	100	100	94	72	69	65	53	43	37
50	100	100	100	100	100	94	77	73	70	56	46	40
65	80	80	80	80	80	76	62	59	56	45	37	32
80	48	48	48	48	48	44	36	34	33	26	22	19

Limitation for SFC-sliding discs: 300°C

ANSI150

DN	Sliding unit: carbon/SFC - stainless steel, coated								Sliding unit: STN2							
	max. admissible pressures for GS3-valves in carbon steel								max. admissible pressures for GS3-valves in carbon steel							
	38°C	50°C	100°C	150°C	200°C	250°C	300°C	350°C	38°C	50°C	100°C	150°C	200°C	250°C	300°C	350°C
15-125	19,6	19,2	17,7	15,8	13,8	12,1	10,2	8,4	19,6	19,2	17,7	15,8	13,8	12,1	10,2	8,4
150	16,0	16,0	16,0	15,8	13,8	12,1	10,2	8,4	16,2	16,2	16,2	15,4	13,8	11,8	9,7	8,0
200	16,0	16,0	16,0	15,8	13,8	12,1	10,2	8,4	10,5	10,0	8,3	7,6	6,9	5,5	4,5	3,9
250	10,5	10,5	10,5	9,9	9,4	8,4	7,4	6,0	5,7	5,7	5,7	5,4	5,1	4,1	3,4	2,6

Limitation for SFC-sliding discs: 300°C

ANSI300

DN	Sliding unit: carbon/SFC - stainless steel, coated								Sliding unit: STN2							
	max. admissible pressures for GS3-valves in carbon steel								max. admissible pressures for GS3-valves in carbon steel							
	38°C	50°C	100°C	150°C	200°C	250°C	300°C	350°C	38°C	50°C	100°C	150°C	200°C	250°C	300°C	350°C
15-50	51,1	50,1	46,6	45,1	43,8	41,9	39,8	37,6	51,1	50,1	46,6	45,1	43,8	41,9	39,8	37,6
65	51,1	50,1	46,6	45,1	43,8	41,9	39,8	37,6	41,7	41,7	41,7	39,7	37,6	33,5	37,6	33,0
80	48,0	48,0	46,6	45,1	43,8	41,9	39,8	37,6	36,6	36,6	36,6	34,8	33,0	26,8	22,0	19,0
100	33,0	33,0	33,0	33,0	33,0	33,0	33,0	33,0	33,0	33,0	33,0	31,7	30,1	24,4	20,0	17,5
125	23,0	23,0	23,0	23,0	23,0	23,0	23,0	23,0	22,1	22,1	22,1	21,0	19,9	16,1	13,2	11,5
150	16,0	16,0	16,0	16,0	16,0	16,0	16,0	16,0	16,0	16,0	16,0	15,4	14,6	11,8	9,7	8,4
200	16,0	16,0	16,0	14,8	13,7	12,1	10,2	8,4	10,5	10,0	8,3	7,6	6,9	5,5	4,5	3,9

Limitation for SFC-sliding discs: 300°C

ANSI600

DN	Sliding unit: carbon/SFC - stainless steel, coated								Sliding unit: STN2							
	max. admissible pressures for GS3-valves in carbon steel								max. admissible pressures for GS3-valves in carbon steel							
	38°C	50°C	100°C	150°C	200°C	250°C	300°C	350°C	38°C	50°C	100°C	150°C	200°C	250°C	300°C	350°C
15-25	102,1	100,2	93,2	90,2	87,6	83,9	79,6	75,1	102,1	100,2	93,2	90,2	87,6	83,9	79,6	75,1
32	102,1	100,2	93,2	90,2	87,6	83,9	79,6	75,1	102,1	100,2	93,2	90,2	87,6	83,9	69,6	60,0
40	100,0	100,0	93,2	90,2	87,6	83,9	79,6	75,1	72,5	72,5	72,5	69,0	65,5	53,1	43,6	37,0
50	100,0	100,0	93,2	90,2	87,6	83,9	79,6	75,1	77,7	77,7	77,7	73,9	70,2	56,9	46,7	40,0
65	80,0	80,0	80,0	80,0	80,0	80,0	79,6	75,1	62,5	62,5	62,5	59,5	56,4	45,8	37,6	32,0
80	48,0	48,0	48,0	48,0	48,0	48,0	48,0	44,0	36,6	36,6	36,6	36,8	33,0	26,8	22,0	19,0

Limitation for SFC-sliding discs: 300°C

Dimensions and Weights

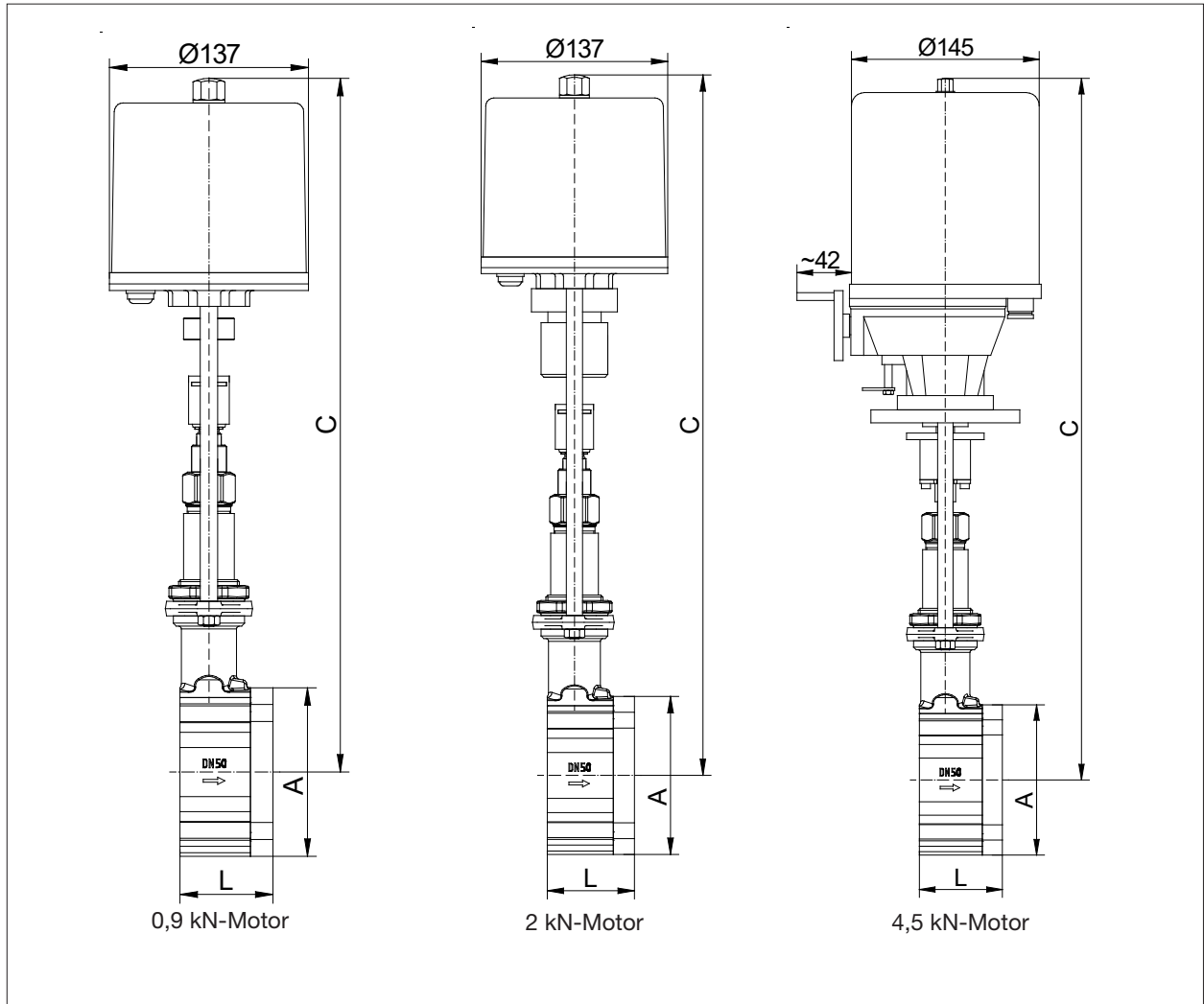

DN	A	C			L	Weight kg			Stroke
		0,9 kN	2 kN	4,5 kN		0,9 kN	2,0 kN	4,5 kN	
15	64	450	487	525	56	4,5	4,8	7,8	6
20	72	455	492	530	56	4,7	5	8	6
25	82	460	497	535	56	5	5,3	8,3	6
32	89	465	502	540	56	5,2	5,5	8,5	6
40	99	470	507	545	56	5,6	5,9	8,9	6
50	116	480	517	555	64	7,1	7,4	10,4	8
65	138	490	527	565	68	8,6	8,9	11,9	8
80	153	495	532	570	70	9,9	10,2	13,2	8
100	184	510	547	585	75	13	13,3	16,3	8,5
125	212	525	562	600	80	15,4	15,7	18,7	8,5
150	242	540	577	615	80	-	19,3	22,3	8,5
200	302	570	607	645	93	-	36	39	8,5
250	360	595	632	670	96	-	41,4	44,4	8,5

dimensions in mm