

Low Temperature Sliding Gate Valve 8026

GS3 series - DN 15 up to DN 100

Pneumatic sliding gate valve optionally with integrated positioner for regulating or shutting off liquid and gaseous media for industrial low temperature applications

- Space saving wafer type construction
- Lowest possible weight
- Quiet operation
- Fast response time
- Control of high differential pressures with small actuators
- Greatly reduced energy consumption rates due to short strokes and low actuating forces on the throttle element
- High Kvs (Cv)-values
- Meets the requirements of TA-Luft 2021



Technical Information

Design	flangeless, wafer-type construction for flanges acc. DIN EN 1092-1 Form B	
Nominal Sizes	DN 15 up to 100 (1/2" - 4")	
Nominal pressure acc. DIN 2401 for flanges with facing type B	PN 40 (fits also to PN 10-25)	DN 15 - DN 100
Nominal pressure acc. ANSI for flanges acc. ASME B 16.5 RF	ANSI 150 ANSI 300	DN 15 - DN 100 DN 15 - DN 100
Nominal pressure acc. JIS for „raised face“ flanges	10K 20K	DN 15 - DN 50 DN 15 - DN 40
Fluid Temperature	down to -200°C	
Ambient temperature*	digital positioner -10°C up to +75°C analog positioner -15°C up to +60°C	
Flange gaskets (customer side)	DIN EN 1514-1 or ANSI B16.21 in the respective nominal pressure rating	
Leakage	Disc pair Carbon-stainless steel	
% of Kvs	< 0,0001	
IEC 60534-4	IV-S1	
EN 12266-1	E	
Marking ATEX non electric	II 2G Ex h IIC T6...T1 X Gb II 2D Ex h IIIC 85°C...530°C X Db	
Spezific leakage rate shaft and body sealing	ISO FE-BH-CC3-SSA0-t(-40°C/+350°C)-PN40-ISO 15848-1	

* Please consider the temperature limitation of the positioner!

* With DN15 with reduction of less than 25%, different leakage rates possible.

K_{vs}-values see data sheet 8001.

Materials

Valve Body	stainless steel 1.4408
Body extension	stainless steel 1.4404
Bodycover	stainless steel 1.4404 or 316L
Diaphragm Casing	aluminium, KTL-coated
Actuator Springs	stainless steel 1.4310
Packung	carbon-filled PTFE (spring 1.4310)
Valve Stem	stainless steel 1.4571, roller burnished
Valve Plate (fixed)	stainless steel, stellite coated
Valve Disc (moving)	special carbon material

Positioner

For technical information of our positioners please refer to the corresponding data sheets.

Admissible Differential Pressures (for temperatures down to -200°C)

digital positioner, Type 8049

(also on-off valves and valves with other side-mounted positioner)

Actuator Size	125 cm ²		250 cm ²		500 cm ²	
Supply air (bar)	4,5	5,5	3,0	4,0	3,0	4,5
DN	max. admissible differential pressure for PN 100-body (bar)					
15	33	33	33	33	33	33
20	33	33	33	33	33	33
25	33	33	33	33	33	33
32	33	33	33	33	33	33
40	33	33	33	33	33	33
50	33	33	33	33	33	33
65	33	33	33	33	33	33
80	23	29	33	33	33	33
100	15	16	25	31	33	33
Spring Configuration	Code 3 (Standard)	Code 4	Code 3 (Standard)	Code 4	Code 6 (Standard)	Code 8

Standard

	Upper limits for admissible pressures in bar			
	PN16	PN40	ANSI150	ANSI 300
P max. stainless steel	16	40	19,0	49,6

p/p- and i/p-positioner, Type 8047

Actuator Size	125 cm ²		250 cm ²		500 cm ²	
Spring Range (bar)	1,5 up to 3,0	1,8 up to 3,8	1,2 up to 2,2	1,5 up to 2,7	1,2 up to 2,2	1,5 up to 2,7
Supply air (bar)	4	5	3	4	3	4,5
DN	max. admissible differential pressure for PN100-body (bar)					
15	33	33	33	33	-	-
20	33	33	33	33	-	-
25	33	33	33	33	33	33
32	33	33	33	33	33	33
40	29	33	33	33	33	33
50	17	21	29	33	33	33
65	14	17	24	29	33	33
80	8	10	14	17	29	33
100	5	6	9	10	18	22
Spring Configuration	Code 3 (Standard)	Code 4	Code 3 (Standard)	Code 4	Code 3 (Standard)	Code 4

Standard

	Upper limits for admissible pressures in bar			
	PN16	PN40	ANSI150	ANSI 300
P max. stainless steel	16	40	19,0	49,6

Application limitations for GS3 valves in stainless steel

These pressure must not be exceeded for GS-valves from the GS3-series made of stainless steel, even though the actuator power might allow it.

PN40

DN	Sliding unit: carbon/SFC - stainless steel, coated						Sliding unit: STN2					
	max. admissible pressures for GS3-valves in stainless steel						max. admissible pressures for GS3-valves in stainless steel					
	100°C	150°C	200°C	250°C	300°C	350°C	100°C	150°C	200°C	250°C	300°C	350°C
15-32	40	40	40	40	40	40	40	40	40	40	40	40
40	40	40	40	40	40	40	40	40	40	40	40	37
50	40	40	40	40	40	40	40	40	40	40	40	40
65	40	40	40	40	40	40	40	40	40	40	37	32
80	40	40	40	40	40	40	36	34	33	26	22	19
100	33	33	33	33	33	33	32	31	30	24	20	17
125	23	23	23	23	23	23	21	21	19	16	13	11
150	16	16	16	16	16	16	15	15	14	11	9	8
200 (only PN16)	16	16	15	13	12	11	8	7	6	5	4	3
250 (only PN16)	10	9	9	8	7	6	-	-	-	-	-	-

Limitation for SFC-sliding discs: 300°C

PN100

DN	Sliding unit: carbon/SFC - stainless steel, coated						Sliding unit: STN2					
	max. admissible pressures for GS3-valves in stainless steel						max. admissible pressures for GS3-valves in stainless steel					
	100°C	150°C	200°C	250°C	300°C	350°C	100°C	150°C	200°C	250°C	300°C	350°C
15	100	100	100	93	84	79	100	100	100	93	84	79
20	100	100	89	81	73	68	100	100	89	81	73	68
25	88	81	70	63	57	54	88	81	70	63	57	54
32	100	93	80	73	65	62	100	93	80	73	65	60
40	88	81	70	63	57	54	72	69	65	53	43	37
50	100	100	100	100	100	94	77	73	70	56	46	40
65	80	80	80	79	71	67	62	59	56	45	37	32
80	48	48	48	48	48	44	36	34	33	26	22	19

Limitation for SFC-sliding discs: 300°C

ANSI150

DN	Sliding unit: carbon/SFC - stainless steel, coated								Sliding unit: STN2							
	max. admissible pressures for GS3-valves in stainless steel								max. admissible pressures for GS3-valves in stainless steel							
	38°C	50°C	100°C	150°C	200°C	250°C	300°C	350°C	38°C	50°C	100°C	150°C	200°C	250°C	300°C	350°C
15-125	19,0	18,4	16,2	14,8	13,7	12,1	10,2	8,4	19,0	18,4	16,2	14,8	13,7	12,1	10,2	8,4
150	16,0	16,0	16,0	14,8	13,7	12,1	10,2	8,4	16,2	16,2	16,2	14,8	13,7	11,8	9,7	8,4
200	16,0	16,0	16,0	14,8	13,7	12,1	10,2	8,4	10,5	10,0	8,3	7,6	6,9	5,5	4,5	3,9
250	10,4	10,4	10,4	9,9	9,4	8,4	7,4	6,8	-	-	-	-	-	-	-	-

Limitation for SFC-sliding discs: 300°C

ANSI300

DN	Sliding unit: carbon/SFC - stainless steel, coated								Sliding unit: STN2							
	max. admissible pressures for GS3-valves in stainless steel								max. admissible pressures for GS3-valves in stainless steel							
	38°C	50°C	100°C	150°C	200°C	250°C	300°C	350°C	38°C	50°C	100°C	150°C	200°C	250°C	300°C	350°C
15-65	49,6	48,1	42,2	38,5	35,7	33,4	31,6	30,3	49,6	48,1	42,2	38,5	35,7	33,4	31,6	30,3
80	48,0	48,0	42,2	38,5	35,7	33,4	31,6	30,3	36,6	36,6	36,6	34,8	33,0	26,8	22,0	19,0
100	33,0	33,0	33,0	33,0	33,0	33,0	31,6	30,3	33,0	33,0	33,0	31,7	30,1	24,4	20,1	17,3
125	23,0	23,0	23,0	23,0	23,0	23,0	23,0	23,0	22,0	22,0	22,0	21,0	19,9	16,1	13,2	11,5
150	16,0	16,0	16,0	16,0	16,0	16,0	16,0	16,0	16,0	16,0	16,0	15,4	14,6	11,8	9,7	8,4
200	16,0	16,0	16,0	14,8	13,7	12,1	10,2	8,4	10,5	10,0	8,3	7,6	6,9	5,5	4,5	3,9

Limitation for SFC-sliding discs: 300°C

ANSI600

DN	Sliding unit: carbon/SFC - stainless steel, coated								Sliding unit: STN2							
	max. admissible pressures for GS3-valves in stainless steel								max. admissible pressures for GS3-valves in stainless steel							
	38°C	50°C	100°C	150°C	200°C	250°C	300°C	350°C	38°C	50°C	100°C	150°C	200°C	250°C	300°C	350°C
15-20	99,3	96,2	84,4	77,0	71,3	66,8	63,2	60,7	99,3	96,2	84,4	77,0	71,3	66,8	63,2	60,7
25	88,0	88,0	84,4	77,0	70,1	63,7	57,3	54,2	88,0	88,0	84,4	77,0	70,1	63,7	57,3	54,2
32	99,3	96,2	84,4	77,0	71,3	66,8	63,2	60,7	99,3	96,2	84,4	77,0	71,3	66,8	63,2	60,2
40	88,0	88,0	84,4	77,0	70,1	63,7	57,3	54,2	72,5	72,5	72,5	69,0	65,5	53,1	43,6	37,7
50	99,3	96,2	84,4	77,0	71,3	66,8	63,2	60,7	77,7	77,7	77,7	73,9	70,2	56,9	46,7	40,4
65	80,0	80,0	80,0	77,0	71,3	66,8	63,2	60,7	62,5	62,5	41,7	59,5	56,4	45,8	37,6	32,5
80	48,0	48,0	48,0	48,0	48,0	48,0	48,0	44,5	36,6	36,6	36,6	34,8	33,0	26,8	22,0	19,0

Limitation for SFC-sliding discs: 300°C

Low Temperature Sliding Gate Valve 8026-GS3

with integrated digital positioner Type 8049

Dimensions and Weights

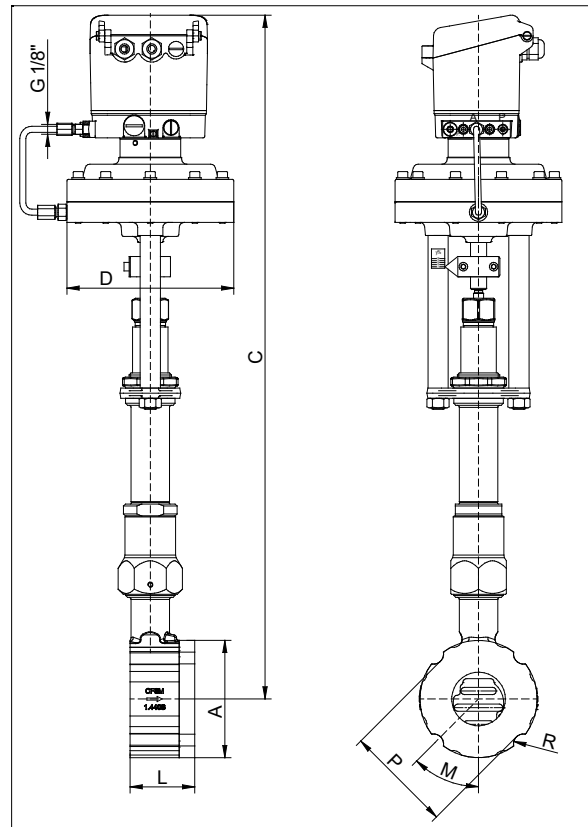

digital positioner
Type 8049

DN	Ø A	C	K	Ø D for actuator		PN 40		ANSI 150		ANSI 300		R	L	Stroke	Weight (kg) for actuator	
15	64	655	595	165	222	53	45	48,8	45	53	45	8	56	6	11,0	13,2
20	72	660	599,5	165	222	63	45	58,2	45	68	45	10	56	6	11,2	13,4
25	82	665	604	165	222	73	45	67,6	45	73	45	10	56	6	11,6	13,8
32	89	670	606,5	165	222	83	45	77	45	83	45	10	56	6	12,0	14,2
40	99	675	612	165	222	94	45	87	45	94	45	10	56	6	12,4	14,6
50	116	685	620,5	165	222	115	45	106	45	112	22,5	10	64	8	14,0	16,2
65	138	695	629,5	165	222	129	22,5	125	45	129	22,5	10	68	8	15,8	18,0
80	153	705	638	165	222	144	22,5	138	45	150	22,5	10	70	8	16,9	19,1
100	184	715	651,3	165	222	164	22,5	176	22,5	182	22,5	10	75	8,50	20,4	22,6

Dimensions in mm

Low Temperature Sliding Gate Valve 8026-GS3

with integrated i/p and p/p - positioner Type 8047

Dimensions and Weights

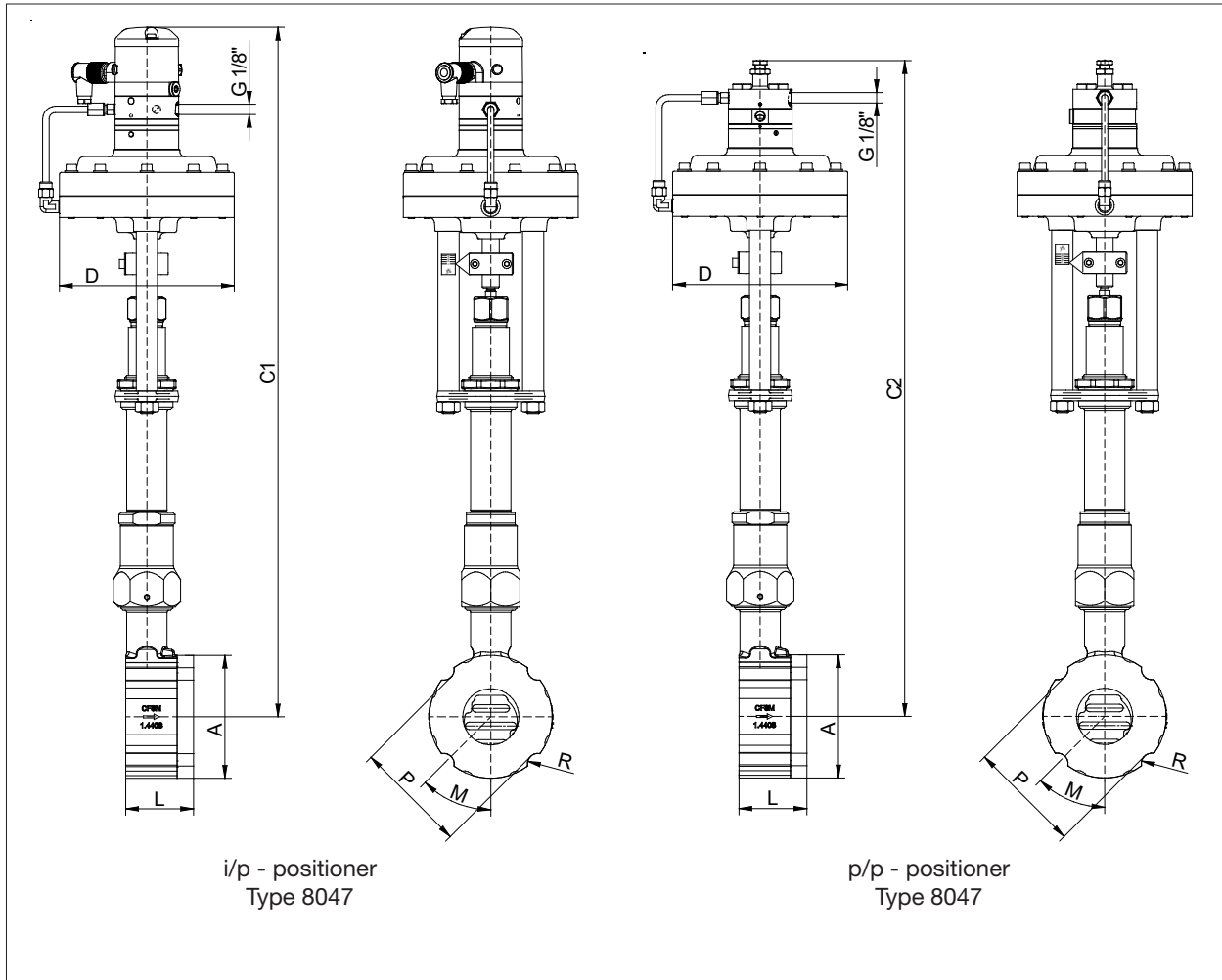

DN	Ø A	C1	C2	Ø D for actuator		PN 40	ANSI 150		ANSI 300		R	L	Stroke	Weight (kg) for actuator		
15	64	625	590	165	222	53	45	48,8	45	53	45	8	56	6	11,0	13,2
20	72	630	595	165	222	63	45	58,2	45	68	45	10	56	6	11,2	13,4
25	82	635	600	165	222	73	45	67,6	45	73	45	10	56	6	11,6	13,8
32	89	640	605	165	222	83	45	77	45	83	45	10	56	6	12,0	14,2
40	99	645	610	165	222	94	45	87	45	94	45	10	56	6	12,4	14,6
50	116	655	620	165	222	106	45	106	45	112	22,5	10	64	8	14,0	16,2
65	138	665	630	165	222	129	22,5	125	45	129	22,5	10	68	8	15,8	18,0
80	153	675	640	165	222	144	22,5	138	45	150	22,5	10	70	8	16,9	19,1
100	184	685	650	165	222	164	22,5	176	22,5	182	22,5	10	75	8,5	20,4	22,6

Dimensions in mm