

# 3/2 - Way Control Valve 7082

with integrated positioner  
1/2" up to 2" 580 psi



**Pneumatically operated 3/2-way control valve in stainless steel with integrated positioner for the control of neutral and aggressive media.**

- Compact design
- All parts in contact with medium made from stainless steel
- For temperatures from -58°F up to +428°F
- Working pressure up to 235 psi
- No moving parts accessible from the exterior
- Non-contact stroke feedback (inductive sensor)
- Operation independent of position and control pressure
- Insensitive to vibration
- Instrument quality air not required for the feed air
- Flexible selection of characteristics using software



## Technical Information

Body material	Stainless steel 1.4408
Nominal sizes	1/2" up to 2"
Connections	NPT thread: 1/2" up to 2"
Nominal pressure	580 psi
Fluid temperature	-22°F up to + 392°F, opt. -58°F up to +428°F
Ambient temperature	digital positioner +14°F up to +167°F analog positioner +5°F up to +140°F

\*: Please consider further temperature versions and limits in technical bulletin 32

## Materials

Body	Stainless steel CF8M
Seating seal	PTFE
Bonnet	Brass chrome plated (actuator Ø 3") Aluminium (actuator Ø 5")
Diaphragm actuator	stainless steel 1.4301
Actuator springs	Stainless steel ASTM A313 302 (actuator Ø 3", 10") Spring steel wire C, zinc coated (actuator Ø 5")
Packing	PTFE (carbon filled), spring ASTM A313 302
Valve stem	Stainless steel 316 Ti, roller burnished
Position indicator	PA Trogamid (clear)

# 3/2 - Way Control Valve in stainless steel 7082 with integrated positioner

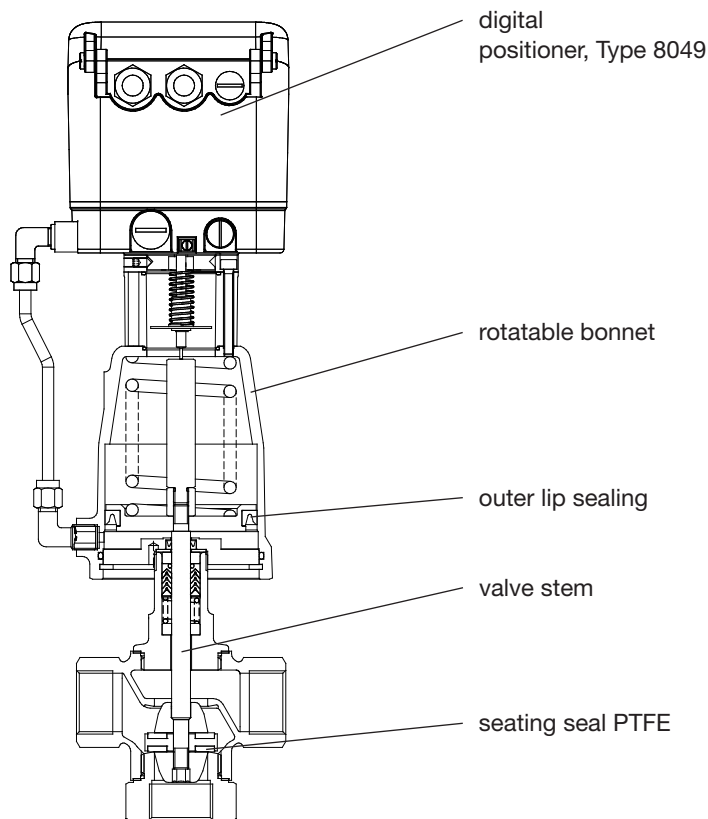

## Cv-Values

Size	Cv - values			
	diverting function		mixing function	
	P-A	P-B	P1-A	P2-A
1/2"	8.7	6.4	6.4	8.7
3/4"	11.6	7.5	7.5	11.6
1"	16.2	11.6	11.6	16.2
1 1/4"	20.9	17.4	17.4	20.9
1 1/2"	52.2	31.3	31.3	52.2
2"	66.1	47.6	47.6	66.1

## Positioner

For technical information of our positioners please refer to the corresponding data sheets.

# 3/2 - Way Control Valve in stainless steel 7082 with integrated positioner



## Admissible Pressures

### Diverting function

digital positioner Type 8049

Size	Differential pressure psi	Supply pressure range psi	Piston Ø inch	Springs Number
1/2" / 3/4"	116	75 - 90	3"	2
1"	116	75 - 90	5"	3
1 1/4"	116	75 - 90	5"	3
1 1/2"	58	65 - 90	10"	4
1 1/2"	87	45 - 65	10"	6
2"	44	60 - 70	10"	6

### Attention:

The maximum pilot pressure must not be exceeded since otherwise the piston rod would be damaged.

### Recommendation:

In order to avoid a damage on the valve because of a too high supply air pressure, we recommend the use of a supply air pressure regulator.

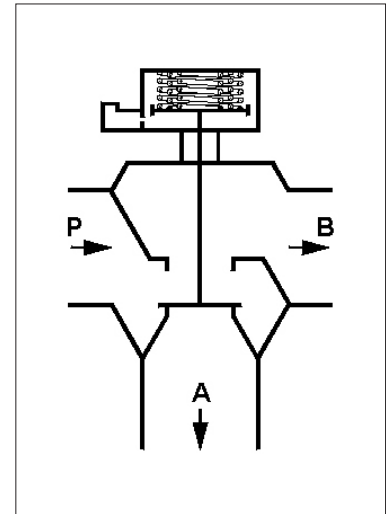

splitting function

### Mixing function

digital positioner Type 8049

Size	Differential pressure psi	Supply pressure range psi	Piston Ø inch	Springs Number
1/2" / 3/4"	218	75 - 90	3"	1
1/2" / 3/4"	232	45 - 50	5"	2
1"	123	75 - 90	3"	1
1"	232	45 - 50	5"	2
1 1/4"	73	75 - 90	3"	1
1 1/4"	160	50 - 55	5"	2
1 1/2"	160	65 - 90	5"	3
1 1/2"	189	45 - 65	10"	6
2"	87	75 - 90	5"	3
2"	131	60 - 70	10"	8

### Attention:

The maximum pilot pressure must not be exceeded since otherwise the piston rod would be damaged.

### Recommendation:

In order to avoid a damage on the valve because of a too high supply air pressure, we recommend the use of a supply air pressure regulator.

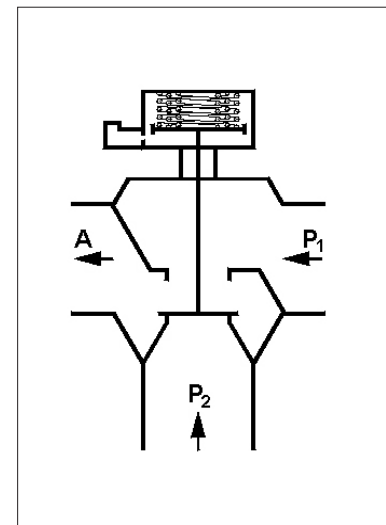

mixing function

# 3/2 - Way Control Valve in stainless steel 7082 with integrated positioner



## Dimensions and Weights

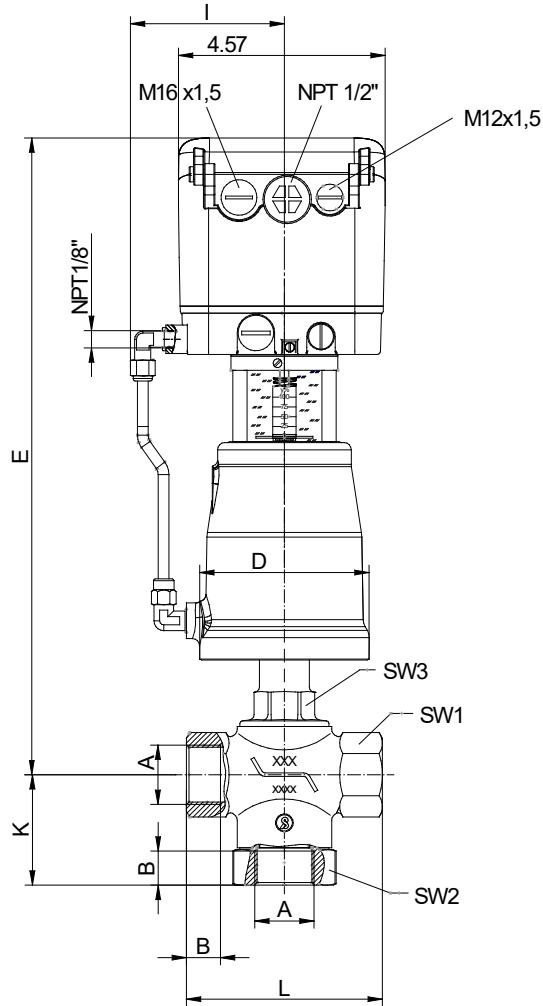

digital positioner Type 8049

Size	Actuator	A NPT	B	B NPT	D	K	L	I Type 8049	E Type 8049	Stroke	SW1	SW2	SW3	Weight (lbs) Type 8049
1/2"	3"	1/2"	0.59	0.57	3.78	2.44	3.54	3.54	13.62	0.55	1.02	1.61	1.18	10.3
1/2"	5"	1/2"	0.59	0.57	5.75	2.44	3.54	4.13	14.41	0.55	1.02	1.61	1.18	14.5
3/4"	3"	3/4"	0.64	0.59	3.78	2.44	3.54	3.54	13.62	0.55	1.26	1.61	1.18	10.3
3/4"	5"	3/4"	0.64	0.59	5.75	2.44	3.54	4.13	14.41	0.55	1.26	1.61	1.18	14.5
1"	3"	1"	0.75	0.71	3.78	2.48	4.33	3.54	14.09	0.55	1.61	2.17	1.18	11.2
1"	5"	1"	0.75	0.71	5.75	2.48	4.33	4.13	14.88	0.55	1.61	2.17	1.18	15.4
1 1/4"	3"	1 1/4"	0.84	0.72	3.78	2.91	5.12	3.54	14.25	0.59	1.89	2.56	1.18	12.5
1 1/4"	5"	1 1/4"	0.84	0.72	5.75	2.91	5.12	4.13	15.04	0.59	1.89	2.56	1.18	16.7
1 1/2"	5"	1 1/2"	0.84	0.72	5.75	3.46	5.51	4.13	15.63	0.91	2.28	2.95	1.26	18.7
2"	5"	2"	1.01	0.75	5.75	3.74	7.09	4.13	16.14	0.91	3.35	3.54	1.42	25.7

Dimensions in inch

# 3/2 - Way Control Valve in stainless steel 7082 with integrated positioner



## Dimensions and Weights

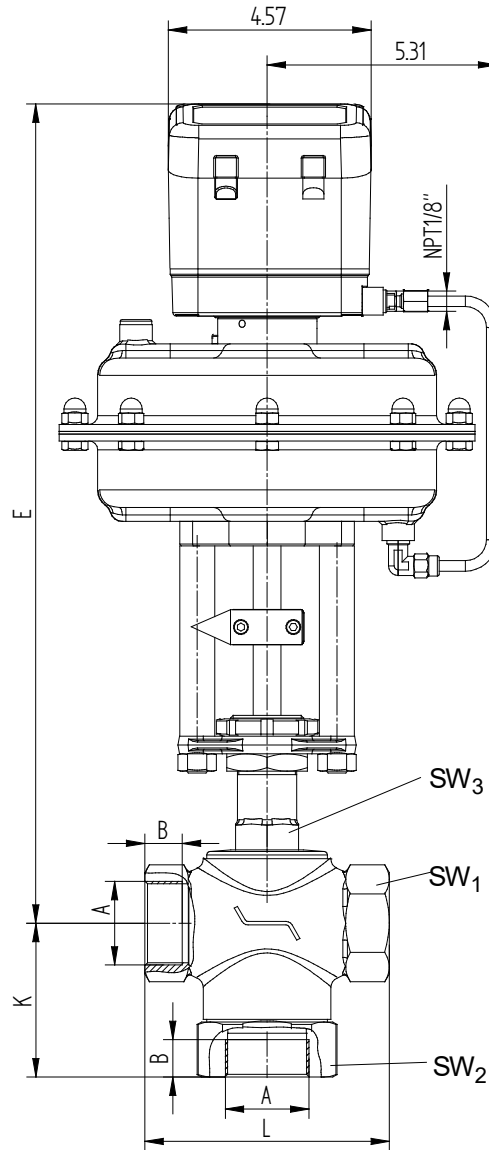

diaphragm actuator  
with digital positioner Type 8049

Size	Actuator	A NPT	B	B NPT	D	K	L	E	Stroke	SW1	SW2	SW3	Weight (lbs)
1 1/2"	10"	1 1/2"	0.84	0.72	9.45	3.46	5.51	18.5	0.91	2.28	2.95	1.26	30.8
2"	10"	2"	1.01	0.75	9.45	3.74	7.09	18.9	0.91	3.35	3.54	1.42	37.8

Dimensions in inch

Text and pictures are not binding. We reserve the right to alter the equipment.