

Flanged Control Valve 7036

DN 15 up to DN 80



Pneumatically operated control valve with integrated positioner for the control of neutral, slightly aggressive and highly aggressive media.

- Unaffected by lightly contaminated media
- Body completely stainless steel
- Integrated positioner
 - pneumatic or
 - electro-pneumatic
 - digital
- Working pressure up to 40 bar
- For temperatures from -100°C up to +220°C



Technical Information

Nominal size	DN 15 up to DN 80, PN40
Connections	flange acc. DIN EN 1092-1 flange acc. ANSI #150 flange acc. ANSI #300
Nominal pressure	PN 40 / ANSI #150 / ANSI #300
Max. fluid temperature:	
with metal bonnet	-30°C up to +200°C, opt. -100°C up to +220°C
with plastic bonnet	-30°C up to +135°C
with diaphragm actuator	-30°C up to +200°C, opt. -30°C up to +220°C
Ambient temperature	analog positioner: -15°C up to +60°C digital positioner: -10°C up to +75°C
Viscosity of the fluid	maximum 600 mm ² /s (600cSt, 80°E)
Vacuum	maximum 0,001 bar abs
Working pressure for packing underneath	maximum 12 bar
Body dimensions	L acc. DIN EN 558-92 (old: DIN 3202-F3)

*: Please consider further temperature versions and limits in technical bulletin 32

Materials

Body	Stainless steel 1.4408
Bonnet	Brass chrome plated (actuator Ø 80 mm) Aluminium corrosion protected (actuator Ø 125 mm)
Diaphragm actuator	Stainless steel 1.4301/1.4305
Actuator springs	Stainless steel 1.4310 (actuator Ø 80 mm, diaphr.act.) Spring steel wire C, zinc coated (actuator Ø 125 mm)
Packing	PTFE (carbon filled), spring 1.4310
Valve stem	Stainless steel 1.4571, roller burnished
Position indicator	PA Trogamid (clear)

Positioner

For technical information of our positioners please refer to the corresponding data sheets.

Flanged Control Valve 7036



with integrated positioner

Kvs-Value

DN	linear					equal percentage				
	15	20	25	32	40	15	20	25	32	40
100 %	3,8	8,8	14	20	27	3	6	10	16	25
40 %	1,5	3,5	5,8	8	11	1,2	2,4	4	6	10
25 %	0,93	2,2	3,6	-	-	0,8	1,5	2,6	-	-
15 %	-	-	-	-	-	0,46	-	-	-	-
10 %	0,4	-	-	-	-	-	-	-	-	-
7,5 %	-	-	-	-	-	0,23	-	-	-	-

Admissible Pressure Difference

digital positioner

DN	Differential pressure	Pilot pressure	Piston Ø	Springs
	bar	bar	mm	Number
15	17	4 bis 6	80	2
20	17	4 bis 6	80	2
25	17	4 bis 6	80	1
32	10	4 bis 6	80	1
32	17	3 bis 6	125	2
40	6	4 bis 6	80	1
40	17	4 bis 6	125	3

p/p-positioner i/p-positioner

DN	Differential pressure	Pilot pressure	Piston Ø	Springs
	bar	bar	mm	Number
15	17	4 - 6	80	2
20	17	4 - 6	80	2
25	12	4 - 6	80	1
32	7	4 - 6	80	1
32	13	3 - 6	125	2
40	4	4 - 6	80	1
40	11	4 - 6	125	3

diaphragm actuator, direct pressure range

DN	Differential pressure (bar)		Supply air (bar)		Diaphragm area (mm ²)
	spring range		spring range		
	0,2 - 1 bar	0,4 - 2 bar	0,2 - 1 bar	0,4 - 2 bar	
15	17	17	1,2	2,4	250
20	17	17	1,2	2,4	250
25	9	17	1,2	2,4	250
32	5	15	1,2	2,4	250
40	3	10	1,2	2,4	250
50	2	6	1,2	2,4	250

Flanged Control Valve 7036, reinforced design with integrated positioner

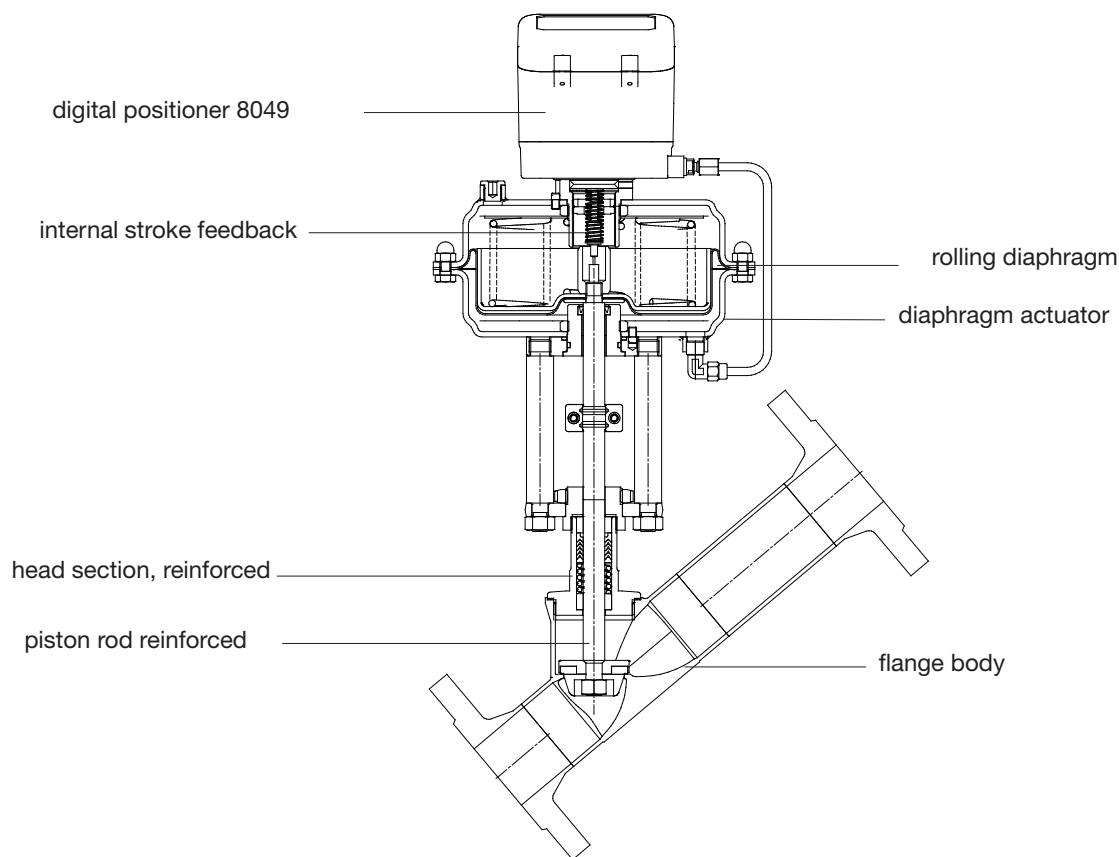

Admissible Pressure Difference

digital positioner

DN	Differential pressure (bar)		Supply pressure range (bar)	Piston Ø (mm)	Springs (number)
	PTFE	PEEK			
50	3	-	4 - 6	80	1
50	11	4	4 - 6	125	3
50	12	5	3 - 6	250	6
50	17	10	4 - 6	250	8 *
50	17	17	4 - 6	250	12
65	5	-	4 - 6	125	3
65	13	8	4 - 6	250	12
80	3	-	4 - 6	125	3
80	9	5	4 - 6	250	12

p/p-positioner i/p-positioner

DN	Differential pressure (bar)	Supply pressure range (bar)	Piston Ø (mm)	Springs (number)
	PTFE			
50	2	4 - 6	80	1
50	6	4 - 6	125	3
50	13	4 - 6	250	10
50	16,9	4 - 6	250	12 *
65	9,3	4 - 6	250	12
80	6,3	4 - 6	250	12

* spring configuration, standard

Kvs-Value

DN	linear			equal percentage		
	50	65	80	50	65	80
100%	43	52	69	34	44	59
63%	26	32	-	23	29	-

Angle Seat Control Valve 7036

Pressure balanced design with integrated positioner

DN50 up to DN80, PN40

Admissible Differential Pressures

digital positioner

DN	Differential pressure (PTFE)	Supply pressure range	Piston Ø	Springs
	bar	bar		
50	17	4 - 6	125	3
65	17	4 - 6	125	3
80	17	4 - 6	125	3

p/p- and i/p-positioner

DN	Differential pressure (PTFE)	Supply pressure range	Piston Ø	Springs
	bar	bar		
50	17	4 - 6	125	3
65	17	4 - 6	125	3
80	17	4 - 6	125	3

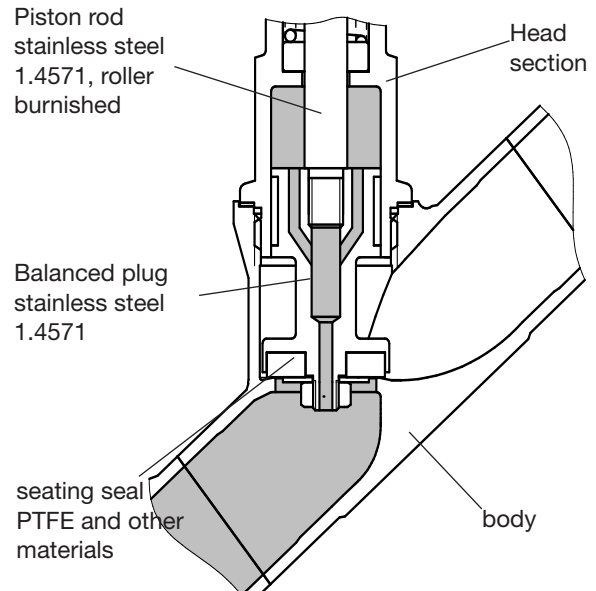

Flanged Control Valve 7036

with integrated positioner

Dimensions and Weights

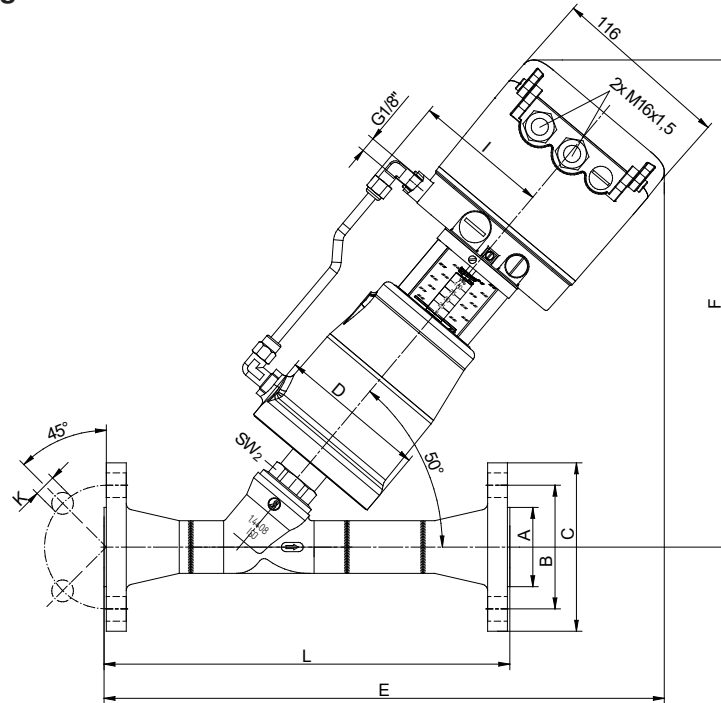

digital positioner Type 8049

PN40

DN	Actuator	I	A	B	C	D	K	Number of borings	L	E	F	SW2	Weight (kg)
15	80	80	45	65	95	98	14	4	230	350	305	30	6
20	80	80	58	75	105	98	14	4	260	355	310	30	6,8
25	80	80	68	85	115	98	14	4	260	360	315	30	7,5
32	80	80	78	100	140	98	18	4	300	375	315	30	8,7
32	125	105	78	100	140	146	18	4	300	405	345	30	11,6
40	80	80	88	110	150	98	18	4	300	380	320	30	9,8
40	125	105	88	110	150	146	18	4	300	410	350	30	12,4

reinforced design:

DN	Actuator	I	A	B	C	D	K	Number of borings	L	E	F	SW2	pressure balanced			Weight (kg)
													E	F	SW2	
50	80	80	102	125	165	98	18	4	350	395	345	32	-	-	-	11,8
50	125	105	102	125	165	146	18	4	350	425	375	32	-	-	-	14,4
65	125	105	122	145	185	146	18	8	400	455	380	41	-	-	-	17,4
80	125	105	138	160	200	146	18	8	450	500	375	41	-	-	-	19,6

ANSI150

DN	Actuator	I	A	B	C	D	K	Number of borings	L	E	F	SW2	Weight (kg)
15	80	80	34,9	60,3	90	98	15,8	4	230	350	305	30	6
20	80	80	42,9	69,9	100	98	15,8	4	260	355	310	30	6,8
25	80	80	50,8	79,4	110	98	15,8	4	260	360	315	30	7,5
32	80	80	63,5	88,9	115	98	15,8	4	300	375	315	30	8,7
32	125	105	63,5	88,9	115	146	15,8	4	300	405	345	30	11,6
40	80	80	73	98,6	125	98	15,8	4	300	380	320	30	9,8
40	125	105	73	98,6	125	146	15,8	4	300	410	350	30	12,4

reinforced design:

DN	Actuator	I	A	B	C	D	K	Number of borings	L	E	F	SW2	pressure balanced			Weight (kg)
													E	F	SW2	
50	80	80	92,1	120,7	150	98	19,1	4	350	395	345	32	-	-	-	11,8
50	125	105	92,1	120,7	150	146	19,1	4	350	425	375	32	-	-	-	14,4
65	125	105	104,8	139,7	180	146	19,1	4	400	455	380	41	-	-	-	17,4
80	125	105	127	152,4	190	146	19,1	4	450	500	375	41	-	-	-	19,6

Dimensions in mm

Flanged Control Valve 7036

with integrated positioner

Dimensions and Weights

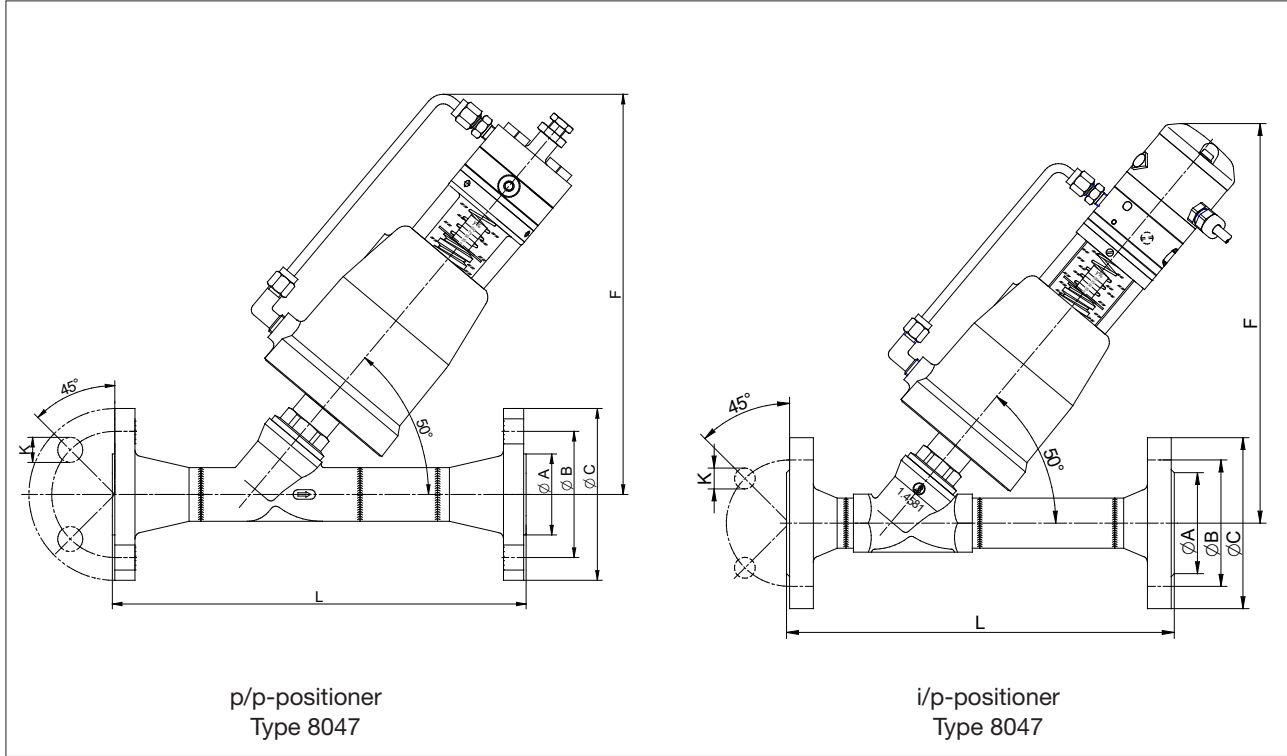

PN40

DN	Actuator	A	B	C	D	K	Number of borings	L	F		H stroke	Weight (kg)	
									p/p	i/p		p/p	i/p
15	80	45	65	95	98	14	4	230	245	260	7	5,3	5,6
20	80	58	75	105	98	14	4	260	245	260	12	6,1	6,4
25	80	68	85	115	98	14	4	260	255	270	16	6,8	7,1
32	80	78	100	140	98	18	4	300	270	285	20	8,4	8,6
32	125	78	100	140	146	18	4	300	300	315	20	10,9	11,2
40	80	88	110	150	98	18	4	300	275	290	23	9,1	9,4
40	125	88	110	150	146	18	4	300	305	320	23	11,7	12

reinforced design:

DN	Actuator	A	B	C	D	K	Number of borings	L	F		H stroke	F		Weight (kg)	
									p/p	i/p		p/p	i/p	p/p	i/p
50	80	102	125	165	98	18	4	350	280	295	29	-	-	11,1	11,4
50	125	102	125	165	146	18	4	350	310	325	29	315	345	13,7	14
65	125	122	145	185	146	18	8	400	305	335	29	325	355	16,7	17
80	125	138	160	200	146	18	8	450	295	335	29	350	380	18,9	19,2

ANSI 150

DN	Actuator	A	B	C	D	K	Number of borings	L	F		H stroke	Weight (kg)	
									p/p	i/p		p/p	i/p
15	80	34,9	60,3	90	98	15,75	4	230	245	260	7	5,3	5,6
20	80	42,9	69,9	100	98	15,75	4	260	245	260	12	6,1	6,4
25	80	50,8	79,4	110	98	15,75	4	260	255	270	16	6,8	7,1
32	80	63,5	88,9	115	98	15,75	4	300	270	285	20	8,4	8,6
32	125	63,5	88,9	115	146	15,75	4	300	300	315	20	10,9	11,2
40	80	73	98,6	125	98	15,75	4	300	275	290	23	9,1	9,4
40	125	73	98,6	125	146	15,75	4	300	305	320	23	11,7	12

reinforced design:

DN	Actuator	A	B	C	D	K	Number of borings	L	F		H stroke	F		Weight (kg)	
									p/p	i/p		p/p	i/p	p/p	i/p
50	80	92,1	120,7	150	98	19,05	4	350	280	295	29	-	-	11,1	11,4
50	125	92,1	120,7	150	146	19,05	4	350	310	325	29	315	345	13,7	14
65	125	104,8	139,7	180	146	19,05	4	400	305	335	29	325	355	16,7	17
80	125	127	152,4	190	146	19,05	4	450	295	335	29	350	380	18,9	19,2

Dimensions in mm

Flanged Control Valve 7036

reinforced design with integrated positioner

Dimensions and Weights

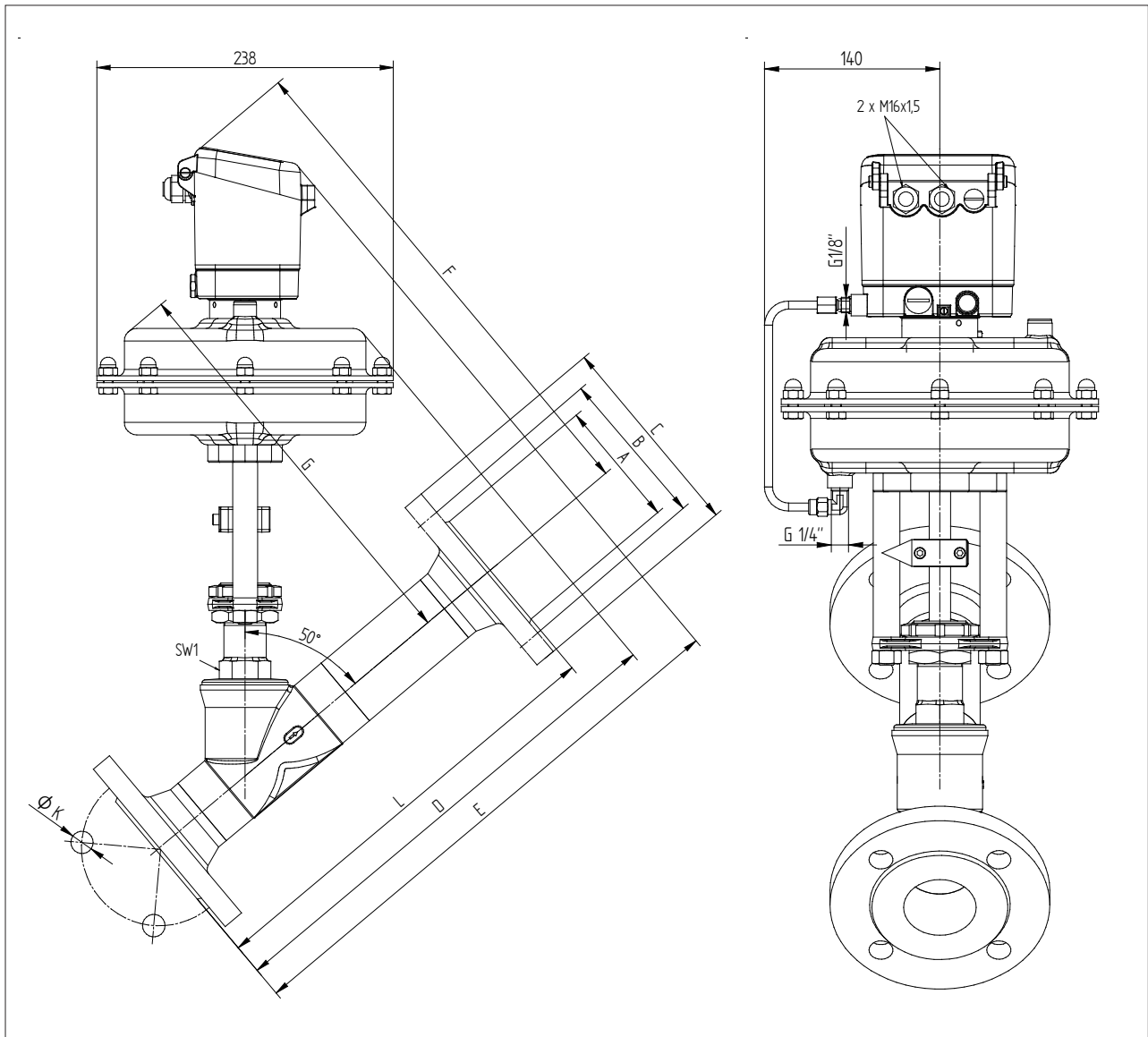

diaphragm actuator with digital positioner 8049

PN40

DN	A	B	C	D	K	number of borings	L	D	G	E	F	SW1	Weight (kg)
15	45	65	95	98	14	4	230	330	280	385	350	30	18,7
20	58	75	105	98	14	4	260	340	290	395	360	30	18,8
25	68	85	115	98	14	4	260	345	300	400	370	30	19
32	78	100	140	146	18	4	300	360	310	415	385	30	19,1
40	88	110	150	146	18	4	300	370	320	425	395	30	19,3
50	102	125	165	146	18	4	350	400	335	445	385	36	19,6
65	122	145	185	146	18	8	400	420	350	465	400	36	20
80	138	160	200	146	18	8	450	470	347	530	415	41	23

ANSI150

DN	A	B	C	D	K	number of borings	L	D	G	E	F	SW1	Weight (kg)
15	35	61	89	98	16	4	230	330	280	385	350	30	18,7
20	43	70	99	98	16	4	260	340	290	395	360	30	18,8
25	51	79	108	98	16	4	260	345	300	400	370	30	19,0
32	64	89	117	146	16	4	300	360	310	415	385	30	19,1
40	73	99	127	146	16	4	300	370	320	425	395	30	19,3
50	92	121	152	146	19	4	350	400	335	450	385	36	19,6
65	107	140	178	146	19	4	400	420	350	490	400	36	20
80	127	152	191	146	19	4	450	470	347	535	415	41	23

Dimensions in mm

Text and pictures are not binding. We reserve the right to alter the equipment.