

Flanged Valve with bellows 7032



1/2" up to 2" 580 psi

Pneumatically operated flanged valves for the control of neutral, lightly and highly aggressive fluids.

- Bellows in stainless steel
- Unaffected by lightly contaminated media
- For temperatures from -148° F up to +428°F
- Working pressures up to 232 psi bars
- Also without bellows, only with lengthened head section available

Technical Information

Nominal sizes	1/2" up to 2"
Body material	1.4408 and 1.4436
Bellows	1.4571
Connection	Flanges acc. DIN EN 1092-1
Dimensions	Acc. DIN EN 558-1 Row 1
Nominal pressure	
with bellow	ANSI 150
without bellow	ANSI 300
Media temperature	
with bellow	-148°F up to +392°F, opt. -148°F up to 428°F
without bellow	-94°F up to +392°F, opt. -94°F up to +428°F
Ambient temperature	-22°F up to +140°F
Working pressure	See tables and diagrams, limitation for dangerous gases acc. Pressure equipment directive 2014/68/EU (category I): PS x DN < 1000
Viscosity of the fluid	maximum 600cSt (600 mm ² /s , 80°E)
Vakuum	maximum 0,015 psi abs
Leakage acc. EN 12266-1	leakage class A

*: Please consider further temperature versions and limits in technical bulletin 32



Options

- e.g.:
- Limit switches
 - inductive proximity switch
 - electrical contact switch
 - pneumatical switch
 - Solenoid valve
 - Additional manual operation
 - Oil and grease free version

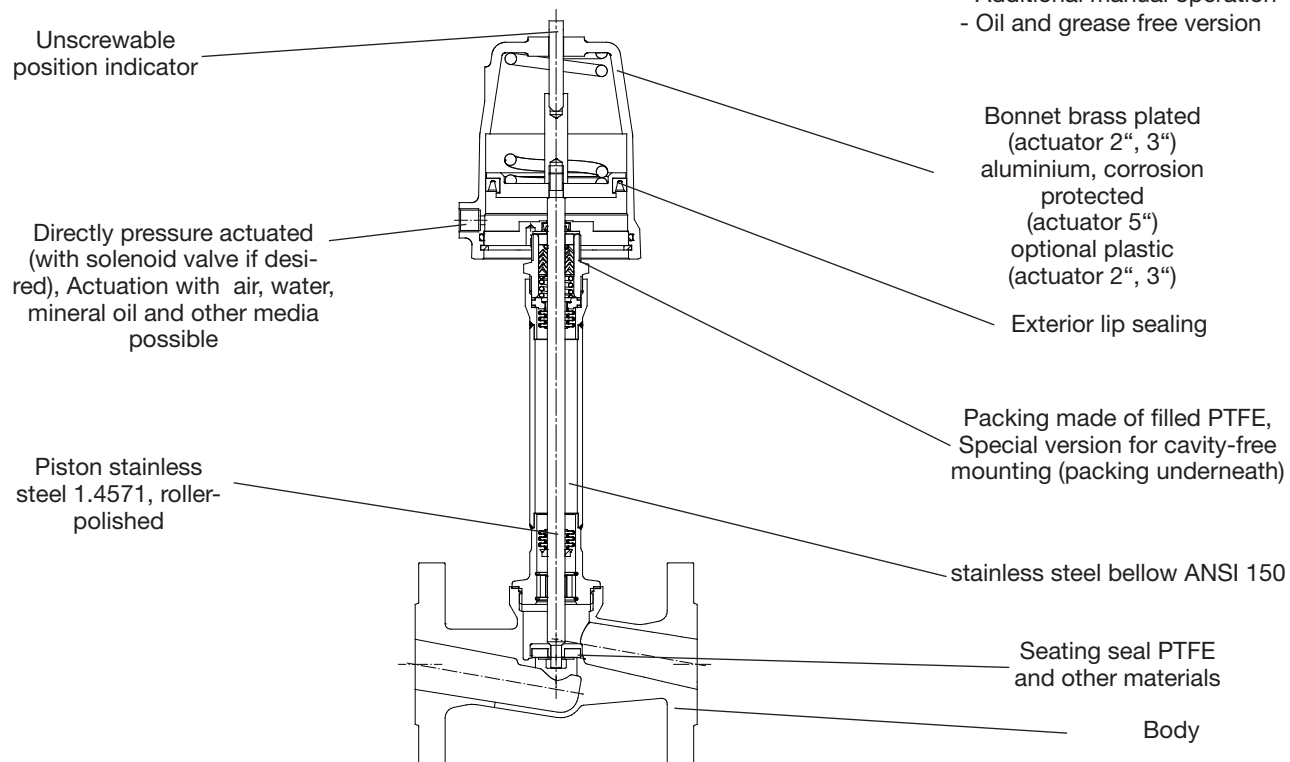

Stress Reversals

Valve		calculated stress reversals at 390°F		
Nom. Size	Actuator	232 psi	145 psi	14,5 psi
1/2"	2	1.000.000	1.000.000	1.000.000
3/4"	2	360.000	900.000	1.000.000
1"	2	340.000	400.000	1.000.000
1"	3	130.000	180.000	200.000
1 1/4"	3	90.000	130.000	170.000
1 1/2"	3	45.000	60.000	75.000
2"	3	40.000	55.000	70.000

At an operating temperature of 20 °C the expected life of the valve will be increased by approx. 30% .

Spring closes NC (closing with flow)

Flanged valves, closing with flow, NO, preferred usage with gaseous media, with liquids closure strokes may occur.

Actuator diameter 2"

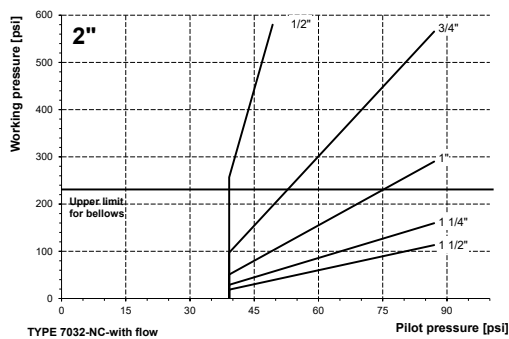

Spring opens NO (closing against flow)

Normally open flanged valves, closing against the flow.

Actuator diameter 2"

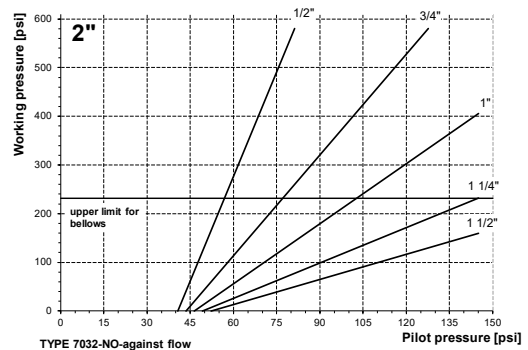

Actuator diameter 3"

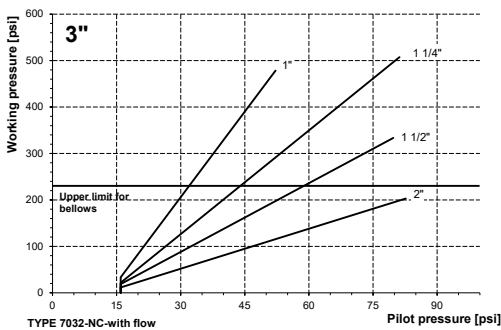

Actuator diameter 3"

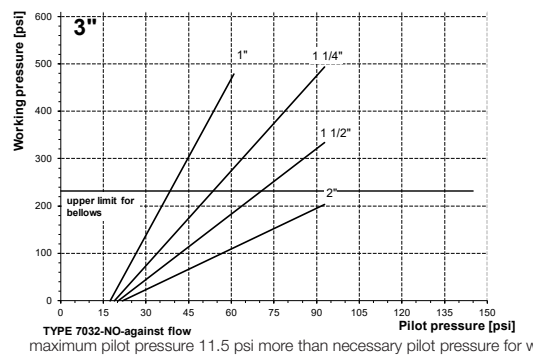

Actuator diameter 5"

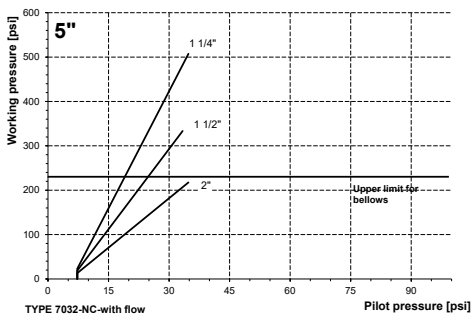

Actuator diameter 5"

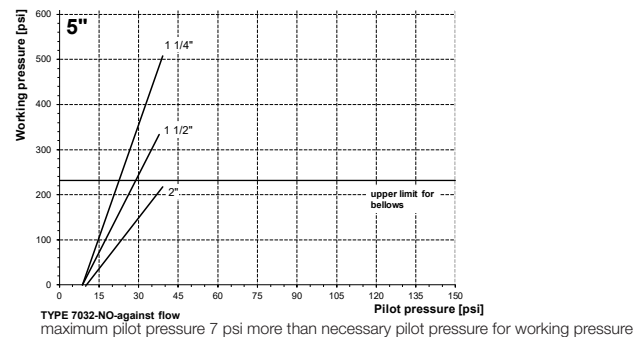

Spring to closed (closing against the flow)

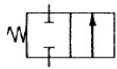

flanged valve, normally closed - closing against the flow, for use with liquid and gaseous media

Nominal size	Working pressure max. (differential pressure) psi	Pilot pressure psi	Piston Ø mm	Springs
1/2"	145	51 - 145	2,0	1
1/2"	247	65 - 145	2,0	2
3/4"	74	51 - 145	2,0	1
3/4"	145	65 - 145	2,0	2
3/4"	232	83 - 145	2,0	3
1"	33	51 - 145	2,0	1
1"	81	65 - 145	2,0	2
1"	129	83 - 145	2,0	3
1"	290	51 - 145	3,1	1
1 1/4"	45	65 - 145	2,0	2
1 1/4"	74	83 - 145	2,0	3
1 1/4"	160	51 - 145	3,1	1
1 1/4"	232	64 - 145	3,1	2
1 1/4"	305	81 - 145	3,1	3
1 1/4"	145	19 - 145	4,9	1
1 1/4"	319	32 - 145	4,9	2

Nominal size	Working pressure max. (differential pressure) psi	Pilot pressure bar	Piston Ø inch	Springs
1 1/2"	28	4,5 - 10	2,0	2
1 1/2"	49	5,7 - 10	2,0	3
1 1/2"	99	3,5 - 10	3,1	1
1 1/2"	139	4,4 - 10	3,1	2
1 1/2"	174	5,6 - 10	3,1	3
1 1/2"	91	1,3 - 10	4,9	1
1 1/2"	203	2,2 - 10	4,9	2
1 1/2"	290	3,1 - 10	4,9	3
2"	58	3,5 - 10	3,1	1
2"	86	4,4 - 10	3,1	2
2"	112	5,6 - 10	3,1	3
2"	126	2,2 - 10	4,9	2
2"	174	3,1 - 10	4,9	3

limitation with bellow nominal pressure 232 psi

Standard (2 Springs)

Ordering Number System

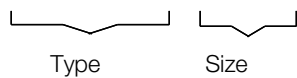
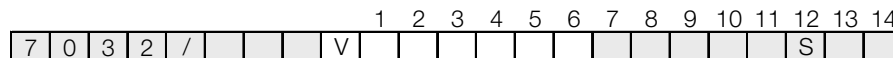

Symbol: "V": Valve
 "A": Actuator (valve without body)
 "R": Repair kit (sealings)

1 - 6 : Please quote all 6 sections.
 7 - 14: Quote only if required.

1. Body type	2. Connection	3. Body material	4. Seating seal	5. Pilot function	6. Actuator	7. Springs
9 flanged valve	1 flange acc. DIN EN 1092-1	2 stainless steel	0 PTFE (Teflon) 1 FKM (Viton) 2 EPDM 3 NBR (standard quality)	0 NC (closing with flow) 1 NO (closing against flow) 2 NC (closing against flow) 3 Universal, double acting	0 piston Ø 2" 1 piston Ø 3,2" 2 piston Ø 4,9" K piston Ø 2" with plastic bonnet M piston Ø 3,2" with plastic bonnet	- standard 1 1 spring 2 2 springs
8.	9. Packing	10. Temperature version	11. Accessories	12. Special versions	13. Other special	13. Head section
-	- standard	- standard H high temperature version +390°F B high temperature HT220	- no accessories 1 electrical position indicator with one switch 2 as above but with two switches 3 manual emergency operation 4 additional manual operation 5 stroke limitation 6 pilot valve DN 2, 230 V AC 7 pilot valve DN 2, 24 V DC K electr. position indicator compact M position indicator with two ind. switches 10 - 36 V DC (PNP) P position indicator with one ind. switches 10 - 36 V DC (PNP) T position indicator compact, inductive 10 - 30 V DC (PNP)	S Special versions M Position indicator with cable bushing N Position indicator with plug connection	-	F lengthened head section with bellows 6 lengthened head section

Ordering example:

7032/050V912021- - - - 5S-F

Flanged valve type 7032, 2", connection DIN flange, body material stainless steel, seating seal PTFE, NC closing against flow, actuator 3", stroke limitation, lengthened head section with bellows

Dimensions and Weights

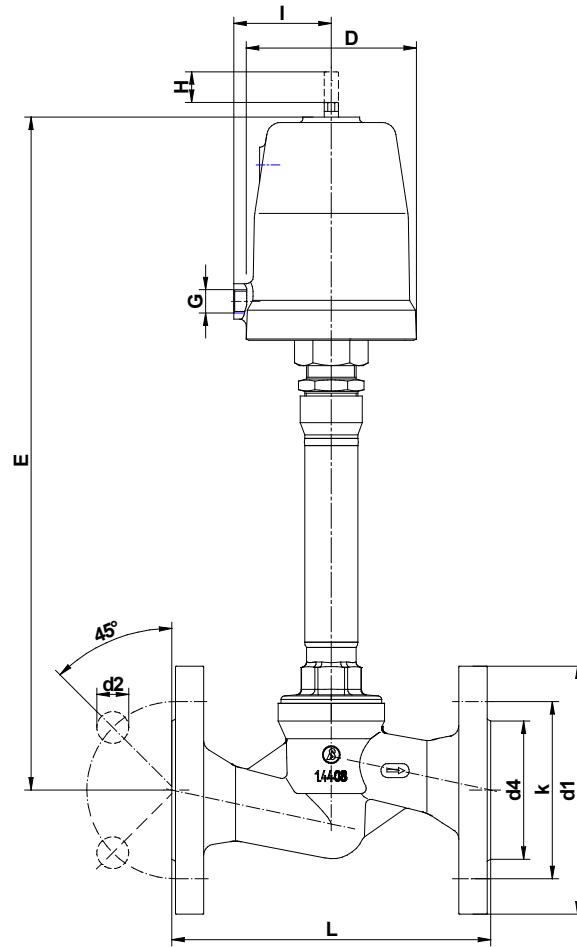

	Actuator	L	D	d1	d2	d4	k	E	G	Stroke	I
1/2"	2	5,1	2,4	3,7	0,6	1,8	2,6	11,8	1/8"	0,5	1,4
3/4"	2	5,9	2,4	4,1	0,6	2,3	3,0	12,0	1/8"	0,6	1,4
1"	2	6,3	2,4	4,5	0,6	2,7	3,3	12,5	1/8"	0,6	1,4
1"	3	6,3	3,9	4,5	0,6	2,7	3,3	14,0	1/4"	0,8	2,2
1 1/4"	3	7,1	3,9	5,5	0,7	3,1	3,9	14,2	1/4"	0,9	2,2
1 1/4"	5	7,1	5,7	5,5	0,7	3,1	3,9	15,2	1/4"	0,9	2,2
1 1/2"	3	7,9	3,9	5,9	0,7	3,5	4,3	14,4	1/4"	1,1	2,2
1 1/2"	5	7,9	5,7	5,9	0,7	3,5	4,3	15,4	1/4"	1,1	2,2
2"	3	9,1	3,9	6,5	0,7	4,0	4,9	15,3	1/4"	1,2	2,2
2"	5	9,1	5,7	6,5	0,7	4,0	4,9	16,3	1/4"	1,2	2,2

Dimensions in mm