

# Angle Seat Manual Valve 7011

DN 15 up to DN 50, PN 40



**Manually operated valve for neutral up to highly aggressive media**

- Not sensitive against slightly contaminated fluids
- All parts contacting the fluid made from stainless steel and plastic
- Backsealing to unburden the stuffing box when the valve is opened
- For temperatures from -40°C up to +200°C

## Technical Information

Orifice sizes	DN 15 up to DN 50 (1/2" - 2")
Connections	BSP thread acc. ISO 228-1 G 1/2" - G 2"
	NPT thread 1/2" - 2"
	Without thread
	Welding ends acc. ISO Welding ends acc. DIN
Body material	Stainless steel mat. no. 1.4408
Nominal pressure	PN 40
Pressure limitation	limitation for dangerous gases acc. Pressure equipment directive 2014/68/EU (category I): PS x DN < 1000
Fluid temperature	-30°C up to +200°C (special versions from -40°C up to +200°C)
Ambient temperature	-20°C up to +100°C (special versions from -40°C up to +100°C)

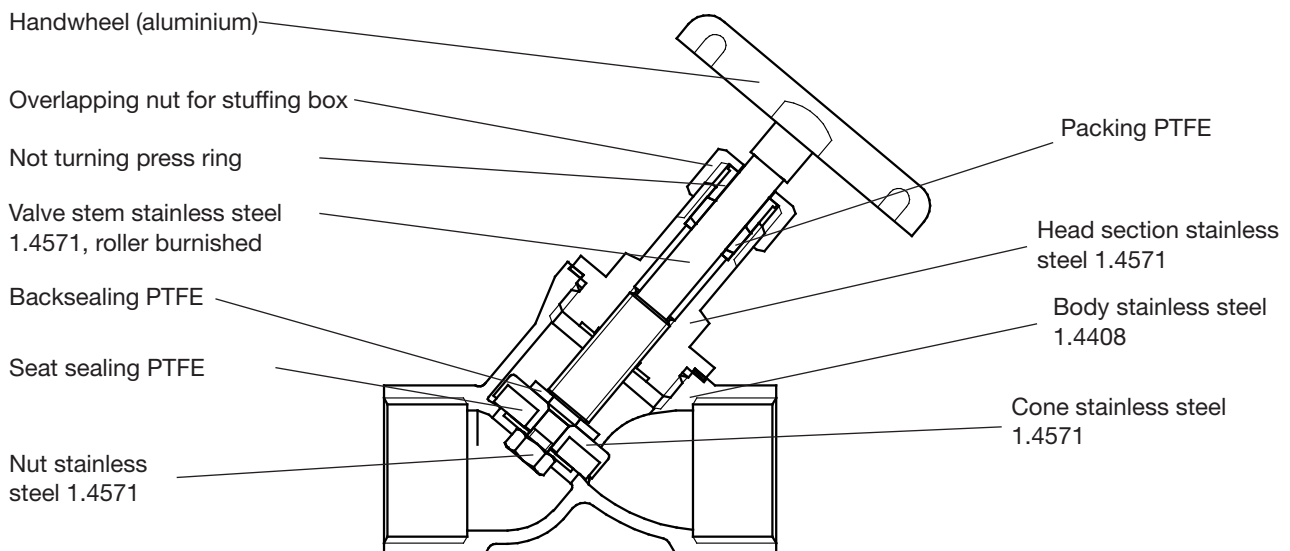
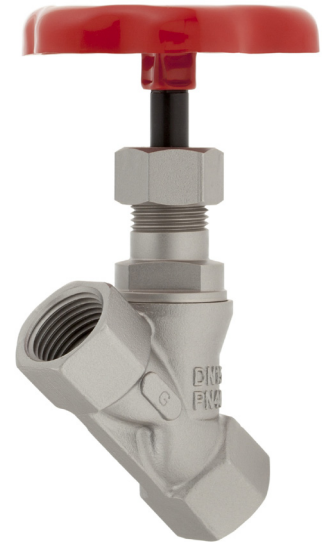

## Dimensions and Weights

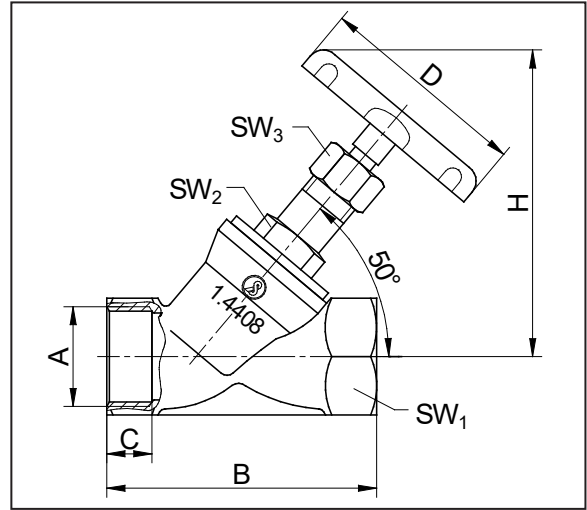
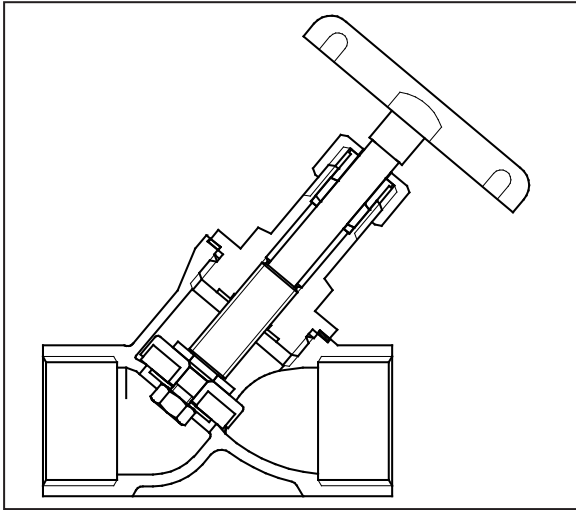

DN	A G/NPT	B	C	D	E		SW1	SW2	SW3	Kvs- Value	Weight (kg)
					opened	closed					
15	1/2"	65	12	60	80	73	25	22	20	3,9	0,190
20	3/4"	75	13	70	96	86	31	22	20	9,6	0,270
25	1"	90	15	70	110	96	39	30	20	17	0,460
32	1 1/4"	110	17	80	132	116	48	30	24	28	0,770
40	1 1/2"	120	19	80	141	122	55	30	24	39	1,160
50	2"	150	21	100	169	144	68	30	27	62	1,720

Dimensions in mm

## Dimensions and weights with weld neck flanges or Tri-Clamp connection

Weld neck flange DIN/ANSI

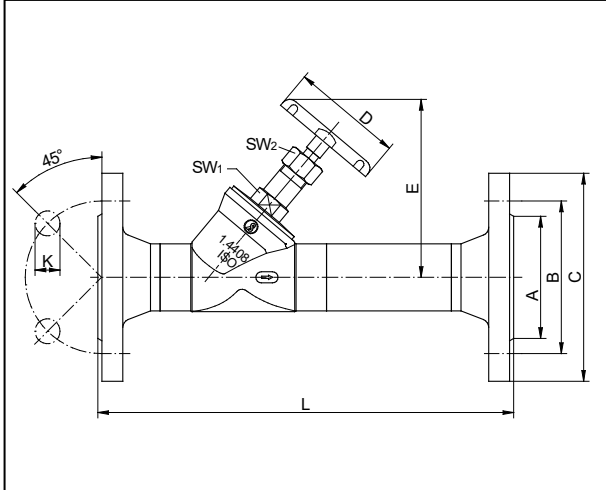

Tri-Clamp connection (Inch)

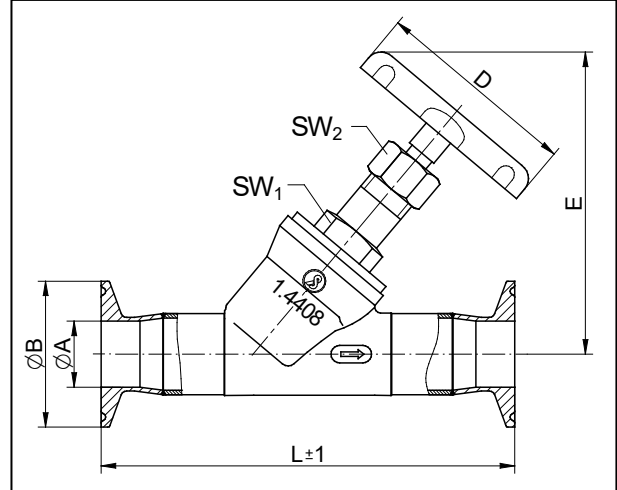

DN	weld neck flange acc. to DIN 2635				weld neck flange acc. to ANSI 150				Tri-Clamp con- nection (Inch)			D	E		SW1	SW2	Kvs- Value	Weight (ca. kg)
	A	B	C	L	A	B	C	L	A	B	L		open	closed				
15	45	65	95	230	35,1	60,5	88,9	230	9,5	25	120	60	80	73	22	19	3,9	0,190
20	58	75	105	260	43	69	98,6	260	15,8	25	130	70	96	86	22	19	9,6	0,270
25	68	85	115	260	50,8	79	108	260	22,9	50,5	142	70	110	96	30	19	17	0,460
32	78	100	140	300	63,5	88,9	117,4	300	31,8	50,5	166	80	132	116	30	24	28	0,770
40	88	110	150	300	73,2	98,6	127	300	35,1	50,5	162	80	141	122	30	24	39	1,160
50	102	125	165	350	92	120,7	152,4	350	47,8	64	192	100	169	144	30	27	62	1,720

Dimensions in mm