

# Angle Seat Valve 7010

1/4" up to 3"; 235 psi up to 580 psi

**Pneumatically operated angle seat valve for the control of neutral, slightly aggressive and highly aggressive media.**

- Compact design
- Unaffected by lightly contaminated media
- For temperatures from -148°F up to +428°F
- Working pressure up to 580 psi
- Versatile actuator options

## Technical Information

Body material	Brass CC754S	Bronze	SST CF8M
Nominal size	2 1/2" and 3"	1/2" - 2"	1/4" - 3"
Connections:			
NPT thread, Tri clamp	2 1/2" and 3"	1/2" - 2"	1/4" - 3"
Welding ends (ISO/SAE), Tube ends	2 1/2" and 3"	1/2" - 2"	1/4" - 3"
Clamp connections			1/2" - 3"
Nominal pressure	235 psi	235 psi	580 psi
Max. fluid temperature*:			
with metal bonnet	-22°F up to 338°F	-22°F up to 338°F	-22°F up to 338°F opt. 86°F up to +390°F
with plastic bonnet diaphragm act., stainless steel	-22°F up to 275°F	opt. -22°F up to +428°F -22°F up to 275°F	-22°F up to 275°F -22°F up to 390°F opt. -22°F up to +428°F
Ambient temperature*	-5°F up to +140°F (versions from -40°F to +212°F possible)		
Vacuum	maximum 0.0295 mercury (Hg)		
Working pressure for packing underneath	maximum 175 psi		
Working pressure for Tri-Clamp connection	maximum 235 psi		
Packing Leakage	ISO FE BH-CC3-SSA1-t(-30°C, +80°C) Test pressure 40 bar		
Leakage acc. EN 12266-1	leakage class A		

\*: Please consider further temperature versions and limits in technical bulletin 32

## Options and accessories

- Stroke limitation
- Manual emergency operation
- El. position indicator with inductive or mechanical limit switches
- Solenoid valves
- AS-I control head
- Oil- and greasefree version, PTFE-free version, siliconfree version
- Versions for oxygen or ozon applications
- FDA-compliant version
- Offshore-version
- Mounting bracket for inductive limit switches
- Version for higher pilot pressures
- Version for under water use
- ...



# Angle Seat Valve 7010

## Build up and function

### Spring closes

The function „spring closes“ may be applied closing against or closing with the flow. In the configuration closing with the flow the valve should only be used for gaseous fluids. If used for liquids, water hammers may occur.

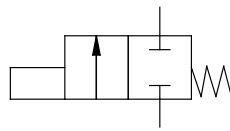

Removable position indicator

Bonnet can be rotated as required (compressed air connection)

Direct pressure control (with a pilot valve if required) actuation by air, water, mineral oil and other media

Head Section

Piston rod stainless steel

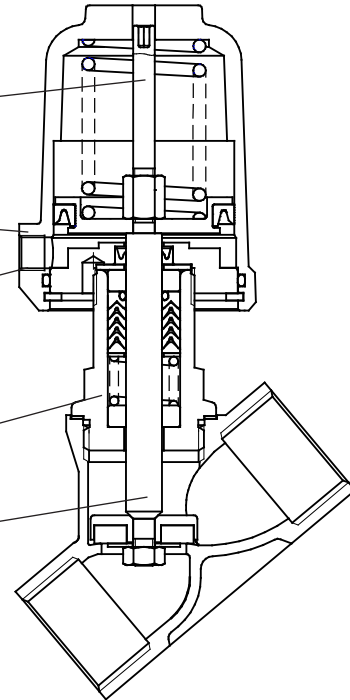

### Spring opens

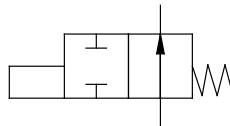

Bonnet material chrome plated brass, plastic, stainless steel or Aluminium

Exterior lip seal

Leak detector

PTFE packing, special version free or (packing underneath)

Seating seal in PTFE or other materials

body with various connection types

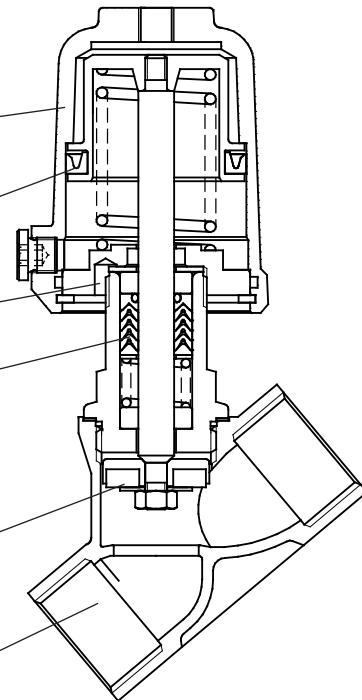

# Angle Seat Valve 7010

## Pilot and operating pressures

### Function „spring closes“, closing against flow

Nominal size	Version	Actuator	Springs	Max. differential pressure [psi]				Pilot pressure [psi]
				Red brass	Stainless steel	Stainless steel	Stainless steel	
				PTFE	PTFE	PEEK 7	PEEK 8	
1/4"	Standard	2"	1	-	580	580	580	51 - 145
3/8"	Standard	2"	1	-	580	140	520	51 - 145
			2	-	580	505	580	66 - 145
			3	-	580	580	580	83 - 145
1/2"	Standard	2"	1	230	310	-	245	51 - 145
			2	230	500	165	435	66 - 145
			3	230	580	375	580	83 - 145
		3"	1	230	580	580	580	51 - 145
			1	100	100	-	53	51 - 145
			2	180	180	-	135	66 - 145
3/4"	Standard	2"	3	230	275	42	220	83 - 145
			1	230	580	360	550	51 - 145
			2	230	580	555	580	64 - 145
		3"	3	230	580	580	580	82 - 145
			1	34	34	-	-	51 - 145
			2	82	82	-	46	66 - 145
1"	Standard	2"	3	130	130	-	95	83 - 145
			1	230	315	140	280	51 - 145
			2	230	435	250	395	64 - 145
		3"	3	230	565	390	525	82 - 145
			1	230	275	97	235	19 - 145
			2	230	580	405	550	33 - 145
		5"	3	230	580	580	580	45 - 145
			1	14	14	-	-	51 - 145
			2	44	44	-	15	66 - 145
1 1/4"	Standard	2"	3	73	73	-	44	83 - 145
			1	180	180	39	150	51 - 145
			2	230	245	105	215	64 - 145
		3"	3	230	315	180	295	82 - 145
			1	150	150	15	125	19 - 145
			2	230	340	200	310	33 - 145
		5"	3	230	485	345	455	45 - 145
			4	230	565	425	535	58 - 145
			8	-	580	580	580	40 - 87
	pressure balanced	2"	2	-	580	-	580	66 - 145
			1	-	580	580	580	51 - 145
			2	-	580	580	580	64 - 145
1 1/2"	Standard	2"	2	27	27	-	-	66 - 145
			3	47	47	-	23	83 - 145
			1	110	110	-	89	51 - 145
		3"	2	155	155	40	130	64 - 145
			3	200	200	89	180	82 - 145
			1	100	100	-	72	19 - 145
	5"	2	220	220	105	200	33 - 145	
		3	230	315	200	295	45 - 145	
		4	-	360	235	340	58 - 145	
	d16	10"	8	-	460	345	435	40 - 87
			12	-	580	525	580	54 - 87
			1	-	500	-	-	51 - 145
pressure balanced	2"	2	-	580	-	275	65 - 145	
		3	-	580	-	580	83 - 145	
		1	-	580	-	580	51 - 145	
	3"	2	-	580	580	580	64 - 145	

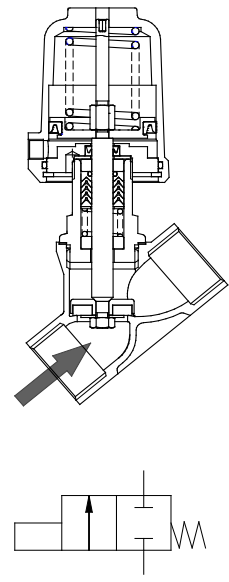

= Standard spring configuration  
 d16: reinforced design with 16mm (0.63") piston rod  
 PEEK 7: Seating seal made of PEEK for use below 320°F  
 PEEK 8: Seating seal made of PEEK for use above 320°F  
 For soft seals such as EPDM, FKM, NBR or Vulkolan the same values as with PTFE are valid

## Pilot and operating pressures

### Function „spring closes“, closing against flow

Nominal size	Version	Actuator	Springs	Max. differential pressure pressure [psi]				Pilot pressure [psi]	
				Red brass	Stainless steel	Stainless steel	Stainless steel		
Body material				PTFE	PTFE	PEEK 7	PEEK 8		
Seating seal									
2"	Standard	2"	2	14	14	-	-	66 - 145	
			3	27	27	-	-	83 - 145	
		3"	1	59	59	-	40	51 - 145	
			2	87	87	-	66	64 - 145	
			3	110	110	17	94	82 - 145	
		5"	1	55	55	-	36	19 - 145	
			2	125	125	34	110	33 - 145	
			3	180	180	87	155	45 - 145	
		d16	5"	3	-	181	87	160	46 - 145
	4			-	185	98	170	58 - 145	
	10"		8	-	280	185	260	40 - 87	
			12	-	395	300	375	54 - 87	
	pressure balanced		2"	2	-	455	-	-	66 - 145
		3		-	580	-	-	83 - 145	
		3"	2	-	580	155	580	64 - 145	
			3	-	580	580	580	82 - 145	
		5"	2	-	580	580	580	33 - 145	
	2 1/2"	Standard	3"	3	60 *	60	-	46	82 - 145
1				24 *	27	-	-	19 - 145	
5"			2	70 *	69	-	56	33 - 145	
			3	100 *	100	29	87	45 - 145	
			3	-	100	29	87	45 - 145	
d16		5"	4	-	105	36	94	58 - 145	
			8	-	155	87	145	40 - 87	
		10"	12	-	215	145	200	54 - 87	
			2	-	300	-	-	66 - 145	
pressure balanced		3"	2	-	360	-	360	64 - 145	
			2	-	360	-	360	33 - 145	
		5"	2	-	360	360	360	45 - 145	
			3	-	360	360	360	45 - 145	
3"		Standard	3"	3	37 *	**	**	**	82 - 145
				1	15 *	**	**	**	19 - 145
	5"		2	43 *	**	**	**	33 - 145	
			3	71 *	**	**	**	45 - 145	
			3	-	68	-	56	46 - 145	
	d16	5"	4	-	72	-	60	58 - 145	
			8	-	105	49	97	40 - 87	
		10"	12	-	150	92	140	54 - 87	
			2	-	360	-	260	67 - 145	
	pressure balanced	3"	3	-	360	-	360	82 - 145	
			2	-	360	-	360	33 - 145	
		5"	2	-	360	-	360	33 - 145	
			3	-	360	88	360	46 - 145	

= Standard spring configuration

\* brass body

\*\* only in reinforced design d16

d16: reinforced design with 16mm (0.63") piston rod

PEEK 7: Seating seal made of PEEK for use below 320°F

PEEK 8: Seating seal made of PEEK for use above 320°F

For soft seals such as EPDM, FKM, NBR or Vulkolan the same values as with PTFE are valid

# Angle Seat Valve 7010

## Pilot and operating pressures

Function „spring opens“, closing against flow

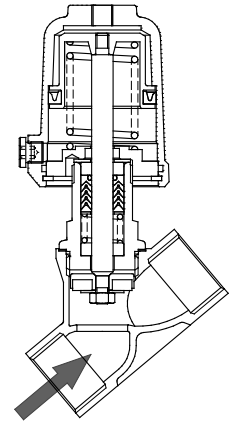

Seating seal PTFE, EPDM, FKM, NBR or Vulkolan

Nominal size	Version	Actuator ø	Max. differential pressure [psi] at available pilot pressure [psi]												
			20	30	40	50	60	70	80	90	100	110	120	130	140
1/4"	Standard	2"	0	0	245	580	580	-	-	-	-	-	-	-	-
3/8"	Standard	2"	0	0	94	380	580	580	-	-	-	-	-	-	-
1/2"	Standard	2"	0	0	47	185	325	465	580	580	-	-	-	-	-
		3"	310	580	-	-	-	-	-	-	-	-	-	-	-
3/4"	Standard	2"	0	0	0	54	120	190	260	330	400	470	540	580	580
		3"	115	300	480	480	580	-	-	-	-	-	-	-	-
1"	Standard	2"	0	0	0	15	56	97	135	180	220	260	300	345	385
		3"	53	160	270	375	485	580	580	-	-	-	-	-	-
1 1/4"	Standard	2"	0	0	0	2	28	54	79	105	130	155	180	205	230
		3"	21	89	155	220	290	355	425	560	580	-	-	-	-
		5"	205	370	535	-	-	-	-	-	-	-	-	-	-
1 1/2"	Standard	2"	0	0	0	0	16	33	51	69	87	105	120	140	155
		3"	8	55	100	145	195	240	290	335	380	430	475	525	570
		5"	135	250	365	480	580	-	-	-	-	-	-	-	-
2"	Standard	2"	0	0	0	0	6	18	30	41	52	64	76	87	99
		3"	0	27	58	88	115	145	175	205	235	270	300	330	360
		5"	80	155	230	300	375	450	525	580	-	-	-	-	-
2 1/2"	Standard	3"	0	12	29	46	63	81	98	115	130	145	165	180	200
		5"	42	84	125	165	210	250	295	335	360	-	-	-	-
	d16	5"	41	83	125	165	205	250	290	330	360	-	-	-	-
3"	Standard*	3"	0	6	18	30	42	54	66	78	90	100	110	125	135
		5"	27	57	86	115	145	170	200	230	-	-	-	-	-
	d16	5"	26	56	85	110	140	170	200	230	260	285	315	345	360

\* brass body

d16: reinforced design with 16mm (0.63") piston rod

Actuator 2": max. pilot pressure 15 psi above the required pilot pressure

Actuator 3": max. pilot pressure 12 psi above the required pilot pressure

Actuator 5" and 10": max. pilot pressure 7 psi above the required pilot pressure

## Pilot and operating pressures

### Function „spring opens“, closing against flow

Seating seal PEEK-8			Max. differential pressure [psi] at available pilot pressure [psi]												
Nominal size	Version	Actuator	20	30	40	50	60	70	80	90	100	110	120	130	140
1/4"	Standard	2"	0	0	115	580	580	-	-	-	-	-	-	-	-
3/8"	Standard	2"	0	0	0	285	575	580	-	-	-	-	-	-	-
1/2"	Standard	2"	0	0	0	120	260	400	540	580	-	-	-	-	-
		3"	245	580	580	-	-	-	-	-	-	-	-	-	-
3/4"	Standard	2"	0	0	0	7	77	145	215	285	350	420	490	560	580
		3"	71	250	435	580	-	-	-	-	-	-	-	-	-
1"	Standard	2"	0	0	0	0	20	61	100	140	185	225	265	305	350
		3"	17	125	230	340	450	555	580	-	-	-	-	-	-
1 1/4"	Standard	2"	0	0	0	0	0	25	51	76	100	125	150	175	205
		3"	0	60	125	195	260	325	395	460	530	580	-	-	-
		5"	175	340	505	580	-	-	-	-	-	-	-	-	-
1 1/2"	Standard	3"	0	31	78	125	170	215	265	310	360	405	450	500	545
		5"	110	225	345	460	575	-	-	-	-	-	-	-	-
2"	Standard	3"	0	8	39	69	99	125	160	190	220	250	280	310	340
		5"	61	135	210	285	360	435	505	580	-	-	-	-	-
2 1/2"	Standard	3"	0	0	15	32	49	66	83	100	115	135	150	165	185
		5"	28	70	110	150	195	235	280	320	360	-	-	-	-
	d16	10"	0	81	165	255	340	-	-	-	-	-	-	-	-
3"	d16	3"	0	0	4	16	27	39	51	62	74	86	97	105	120
		5"	14	44	73	100	130	160	185	215	245	275	305	335	360
		10"	0	52	110	170	230	290	350	-	-	-	-	-	-

Seating seal PEEK-7			Max. differential pressure [psi] at available pilot pressure [psi]												
Nominal size	Version	Actuator	20	30	40	50	60	70	80	90	100	110	120	130	140
1/4"	Standard	2"	0	0	245	580	580	-	-	-	-	-	-	-	-
3/8"	Standard	2"	0	0	94	380	580	580	-	-	-	-	-	-	-
1/2"	Standard	2"	0	0	47	185	325	465	580	580	-	-	-	-	-
		3"	310	580	-	-	-	-	-	-	-	-	-	-	-
3/4"	Standard	2"	0	0	0	54	120	190	260	330	400	470	540	580	580
		3"	115	300	480	580	-	-	-	-	-	-	-	-	-
1"	Standard	3"	53	160	270	375	485	580	580	-	-	-	-	-	-
		5"	350	580	-	-	-	-	-	-	-	-	-	-	-
1 1/4"	Standard	3"	21	89	155	220	290	355	425	490	560	580	-	-	-
		5"	205	370	535	-	-	-	-	-	-	-	-	-	-
1 1/2"	Standard	3"	8	55	100	145	195	240	290	335	380	430	475	525	570
		5"	135	250	365	480	580	-	-	-	-	-	-	-	-
2"	Standard	3"	0	27	58	88	115	145	175	205	235	270	300	330	360
		5"	80	155	230	300	375	450	525	580	-	-	-	-	-
		10"	22	175	325	480	-	-	-	-	-	-	-	-	-
2 1/2"	Standard	5"	42	84	125	165	210	250	295	335	360	-	-	-	-
	d16	10"	9	96	180	265	355	-	-	-	-	-	-	-	-
3"	d16	5"	26	56	85	110	140	170	200	230	260	285	315	345	360
		10"	4	64	125	185	245	305	360	-	-	-	-	-	-

d16: reinforced design with 16mm (0.63") piston rod

PEEK 7: Seating seal made of PEEK for use below 320°F

PEEK 8: Seating seal made of PEEK for use above 320°F

Actuator 2": max. pilot pressure 15 psi above the required pilot pressure

Actuator 3": max. pilot pressure 12 psi above the required pilot pressure

Actuator 5" and 10": max. pilot pressure 7 psi above the required pilot pressure

# Angle Seat Valve 7010

## Pilot and operating pressures

### Function „spring closes“, closing with flow

- Angled seat valve closing with the flow, spring closes
- Use preferably for gaseous fluids
- With liquids waterhammers are possible

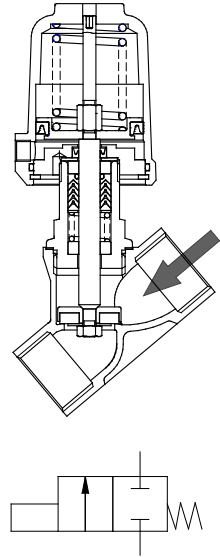

Seating seal PTFE, EPDM, FKM, NBR or Vulkolan

Nominal Size	Version	Actuator	Max. differential pressure [psi] at available pilot pressure [psi]												
			20	30	40	50	60	70	80	90	100	110	120	130	140
1/4"	Standard	2"	0	0	580	580	580	580	580	580	580	580	580	580	580
3/8"	Standard	2"	0	0	580	580	580	580	580	580	580	580	580	580	580
1/2"	Standard	2"	0	0	195	530	580	580	580	580	580	580	580	580	580
3/4"	Standard	2"	0	0	92	185	285	380	480	580	580	580	580	580	580
		3"	145	400	580	580	580	580	580	580	580	580	580	580	580
1"	Standard	2"	0	0	58	105	155	205	255	305	355	405	455	475	475
		3"	80	210	340	470	475	475	475	475	475	475	475	475	475
1 1/4"	Standard	2"	0	0	34	62	91	120	145	175	205	230	260	275	275
		3"	49	120	200	275	350	425	500	505	505	505	505	505	505
		5"	250	435	505	505	505	505	505	505	505	505	505	505	505
1 1/2"	Standard	2"	0	0	34	62	91	120	145	175	205	230	260	275	275
		3"	0	43	94	140	195	245	295	330	330	330	330	330	330
		5"	70	195	320	330	330	330	330	330	330	330	330	330	330
	d16	5"	67	190	315	435	560	580	580	580	580	580	580	580	
2"	Standard	2"	0	0	0	0	32	44	56	69	81	93	105	115	115
		3"	0	33	65	97	125	160	190	215	215	215	215	215	215
		5"	50	125	205	215	215	215	215	215	215	215	215	215	215
		d16	49	125	200	280	355	435	510	550	550	550	550	550	550
2 1/2"	Standard	3"	0	18	35	53	71	88	105	120	140	155	170	170	170
		5"	27	71	110	155	170	170	170	170	170	170	170	170	170
		d16	26	69	110	155	195	240	280	290	290	290	290	290	290
3"	Standard *	3"	0	12	24	36	49	61	73	85	97	110	120	130	130
		5"	19	49	79	105	130	130	130	130	130	130	130	130	130
	d16	3"	0	0	0	0	29	41	53	65	77	88	100	110	120
		5"	18	48	77	105	135	165	185	185	185	185	185	185	185
		10"	0	0	135	185	185	185	185	185	185	-	-	-	-

\* brass body

d16: reinforced design with 16mm (0.63") piston rod

# Angle Seat Valve 7010



## Pilot and operating pressures

### Function „spring closes“, closing with flow

Seating seal PEEK-8

Nominal Size	Version	Actuator	Springs	Max. differential pressure [psi] at available pilot pressure [psi]												
				20	30	40	50	60	70	80	90	100	110	120	130	140
1/4"	Standard	2"	1	0	0	0	580	580	580	580	580	580	580	580	580	580
3/8"	Standard	2"	1	0	0	0	580	580	580	580	580	580	580	580	580	580
1/2"	Standard	2"	2	0	0	0	0	125	460	580	580	580	580	580	580	580
3/4"	Standard	2"	2	0	0	0	9	105	200	300	395	495	580	580	580	580
		3"	1	0	0	0	190	445	580	580	580	580	580	580	580	580
		5"	1	260	580	580	580	580	580	580	580	580	580	580	580	580
1"	Standard	2"	2	0	0	0	27	77	125	175	225	275	325	375	425	475
		3"	1	0	0	0	125	255	385	475	475	475	475	475	475	475
		5"	1	260	580	580	580	580	580	580	580	580	580	580	580	580
1 1/4"	Standard	2"	2	0	0	0	17	45	74	100	130	160	185	215	245	275
		3"	1	0	0	12	88	160	235	310	385	460	505	505	505	505
		5"	1	95	280	465	505	505	505	505	505	505	505	505	505	505
1 1/2"	Standard	3"	1	0	0	17	68	115	170	220	270	320	330	330	330	330
		5"	2	0	59	185	310	330	330	330	330	330	330	330	330	330
	d16	5"	2	0	56	180	300	425	550	580	580	580	580	580	580	580
2"	Standard	3"	2	0	0	0	25	57	89	120	150	180	215	215	215	215
		5"	2	0	50	125	205	215	215	215	215	215	215	215	215	215
	d16	5"	2	0	47	125	200	280	355	435	510	550	550	550	550	550
		10"	6	41	200	360	520	550	550	550	550	-	-	-	-	-
2 1/2"	Standard	5"	2	0	27	70	110	155	170	170	170	170	170	170	170	
		5"	2	0	25	68	110	150	195	240	280	290	290	290	290	
	d16	10"	6	23	110	200	290	290	290	290	290	-	-	-	-	
3"	d16	5"	2	0	17	47	77	105	135	165	185	185	185	185	185	
		10"	6	15	77	135	185	185	185	185	185	-	-	-	-	

# Angle Seat Valve 7010



## Pilot and operating pressures

### Function „spring closes“, closing with flow

Seating seal PEEK-7

Nominal Size	Version	Actuator	Springs	Max. differential pressure [psi] at available pilot pressure [psi]												
				20	30	40	50	60	70	80	90	100	110	120	130	140
1/4"	Standard	2"	1	0	0	0	580	580	580	580	580	580	580	580	580	580
3/8"	Standard	2"	1	0	0	0	580	580	580	580	580	580	580	580	580	580
1/2"	Standard	2"	2	0	0	0	0	125	460	580	580	580	580	580	580	580
3/4"	Standard	3"	1	0	0	0	190	445	580	580	580	580	580	580	580	580
			1	260	580	580	580	580	580	580	580	580	580	580	580	
1"	Standard	3"	1	0	0	0	125	255	385	475	475	475	475	475	475	475
			1	150	470	475	475	475	475	475	475	475	475	475	475	475
1 1/4"	Standard	3"	2	0	0	0	12	88	160	235	310	385	460	505	505	505
		5"	1	95	280	465	505	505	505	505	505	505	505	505	505	505
1 1/2"	Standard	3"	2	0	0	0	20	70	120	170	220	270	325	330	330	330
		5"	2	0	59	185	310	330	330	330	330	330	330	330	330	330
	d16	5"	2	0	56	180	300	425	550	580	580	580	580	580	580	580
2"	Standard	5"	2	0	50	125	205	215	215	215	215	215	215	215	215	215
		5"	2	0	47	125	200	280	355	435	510	550	550	550	550	
	d16	10"	6	41	200	360	520	550	550	550	550	-	-	-	-	
2 1/2"	Standard	5"	3	0	0	39	82	125	165	170	170	170	170	170	170	170
		5"	3	0	0	37	80	120	165	205	250	290	290	290	290	
	d16	10"	6	23	110	200	290	290	290	290	290	290	290	290	290	
3"	d16	5"	2	0	17	47	77	105	135	165	185	185	185	185	185	185
		10"	6	15	77	135	185	185	185	185	185	-	-	-	-	

d16: reinforced design with 16mm (0.63") piston rod

PEEK 7: Seating seal made of PEEK for use below 320°F

PEEK 8: Seating seal made of PEEK for use above 320°F

# Angle Seat Valve 7010



standard design

## Dimensions and Weights

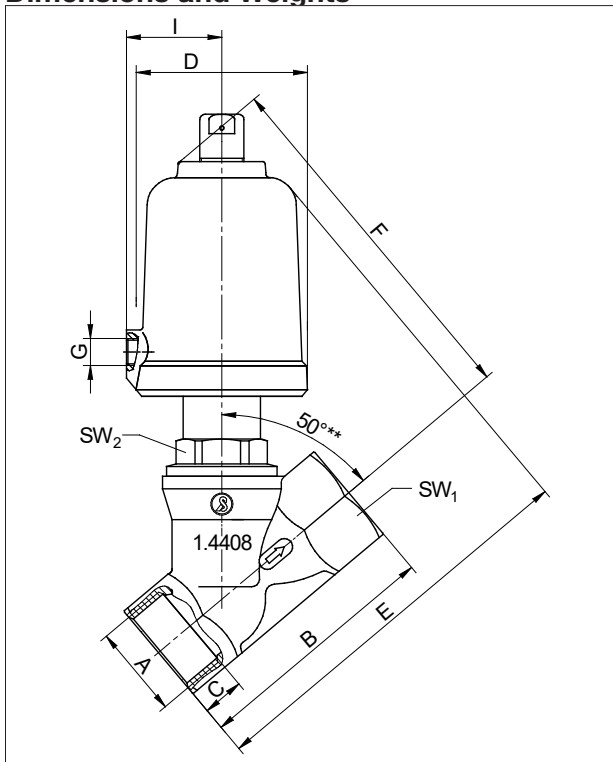

Normal closed

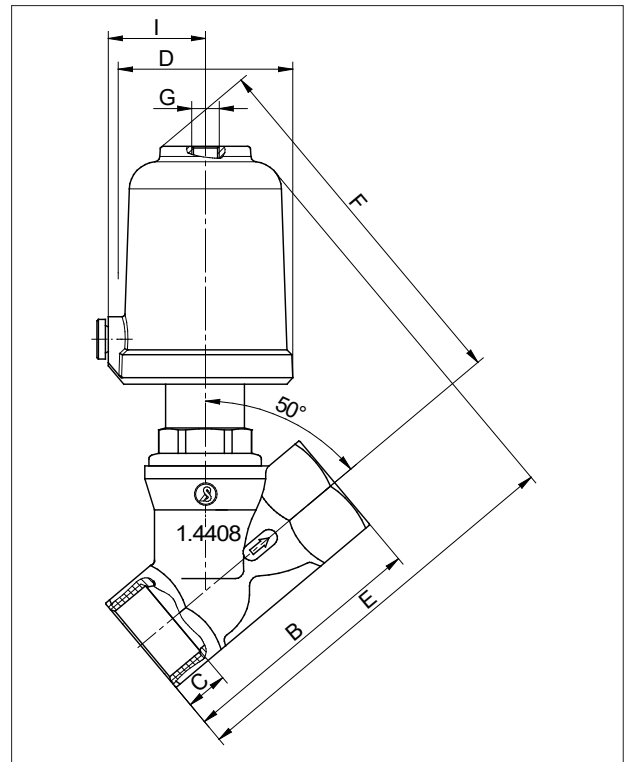

Normal open

\*\* <= 45° for size 2.5", brass body for 3" and stainless steel body for 3"

Size	actuator	A		B		C	D		E		F	G	H (stroke)	I	SW1		SW2		Cv-values		weight (lbs)
		G/ NPT	bronze/ SST	bronze/ SST	brass		bronze/ SST	brass	bronze/ SST	brass					stand.	reinfor.	bronze/ SST	brass			
1/4"	2"	1/4"	2.35	-	0.45	2.45	5.1	-	4.85	G1/8"	0.33	1.35	0.8	-	1.2	-	1.1	-	2.2		
3/8"	2"	3/8"	2.35	-	0.45	2.45	5.1	-	4.85	G1/8"	0.35	1.35	0.9	-	1.2	-	1.9	-	2.31		
1/2"	2"	1/2"	2.55	-	0.6	2.45	5.3	-	4.7	G1/8"	0.28	1.35	1	-	1.2	-	4.1	-	2.42		
3/4"	2"	3/4"	2.95	-	0.65	2.45	5.3	-	4.9	G1/8"	0.47	1.35	1.2	-	1.2	-	9.3	-	2.64		
1"	2"	1"	3.55	-	0.75	2.45	5.7	-	5.1	G1/8"	0.63	1.35	1.55	-	1.2	-	17.4	-	3.08		
1"	3"	1"	3.55	-	0.75	3.8	7.3	-	6.7	G1/4"	0.63	2.15	1.55	-	1.2	-	18.6	-	6.6		
1 1/4"	2"	1 1/4"	4.35	-	0.85	2.45	6.3	-	5.7	G1/8"	0.63	1.35	1.9	-	1.2	-	24.4	-	3.96		
1 1/4"	3"	1 1/4"	4.35	-	0.85	3.8	7.85	-	7.5	G1/4"	0.79	2.15	1.9	-	1.2	-	27.8	-	7.26		
1 1/4"	5"	1 1/4"	4.35	-	0.85	5.75	9.05	-	8.45	G1/4"	0.79	3.15	1.9	-	1.2	-	27.8	-	12.1		
1 1/2"	2"	1 1/2"	4.7	-	0.85	2.45	6.5	-	5.9	G1/8"	0.63	1.35	2.15	-	1.2	-	34.8	-	4.62		
1 1/2"	3"	1 1/2"	4.7	-	0.85	3.8	8.05	-	7.7	G1/4"	0.91	2.15	2.15	-	1.2	-	40.6	-	7.92		
1 1/2"	5"	1 1/2"	4.7	-	0.85	5.75	9.25	-	8.65	G1/4"	0.91	3.15	2.15	-	1.2	-	40.6	-	12.76		
2"	2"	2"	5.9	-	1	2.45	7.3	-	6.3	G1/8"	0.63	1.35	2.7	-	1.25	-	46.4	-	5.94		
2"	3"	2"	5.9	-	1	3.8	8.85	-	7.85	G1/4"	1.14	2.15	2.7	-	1.25	1.4	63.8	-	9.24		
2"	5"	2"	5.9	-	1	5.75	9.85	-	8.85	G1/4"	1.14	3.15	2.7	-	1.25	1.4	63.8	-	14.08		
2 1/2"	3"	2 1/2"	7.1	7.1	1.2	3.8	10.25	10.25	8.65	G1/4"	1.14	2.15	3.35	3.35	1.4	1.6	92.8	107.9	13.64		
2 1/2"	5"	2 1/2"	7.1	7.1	1.2	5.75	11.2	11.2	9.85	G1/4"	1.14	3.15	3.35	3.35	1.4	1.6	92.8	107.9	18.48		
3"	3"	3"	-	8.25	1.3	3.8	-	11	8.85	G1/4"	1.14	2.15	-	3.95	1.6	1.6	-	133.4	18.26		
3"	5"	3"	-	8.25	1.3	5.75	-	12	9.85	G1/4"	1.14	3.15	-	3.95	1.6	1.6	-	133.4	23.1		

\*Dimensions in inch

# Angle Seat Valve 7010

reinforced design with diaphragm actuator



## Dimensions and Weights

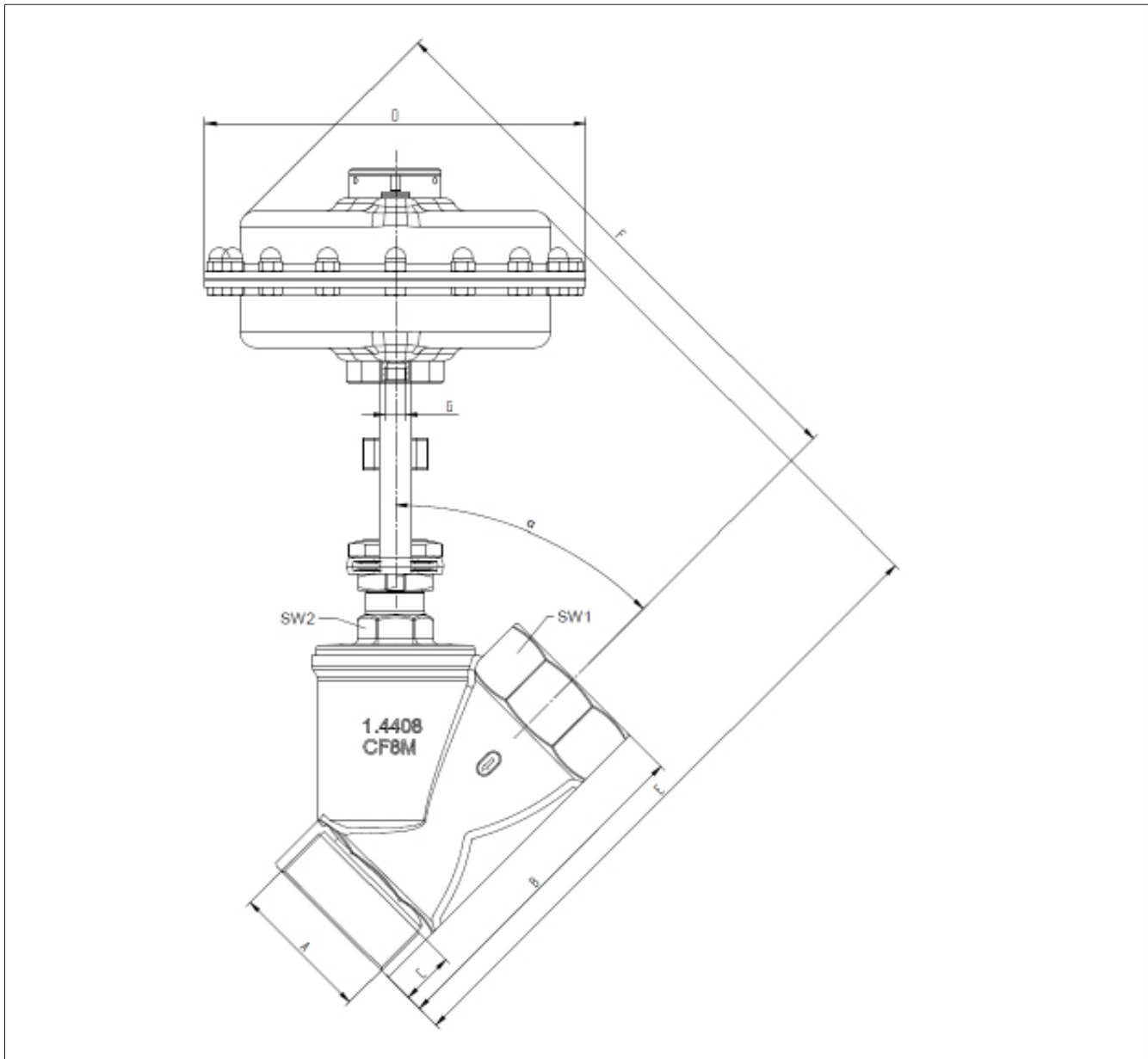

Size	Actuator	A Rp/NPT	B	C	D	E	F	G	Stroke (inch)	SW1	SW2	$\alpha$	cv- value	Weight (lbs)
2"	10"	2"	5.91	1.01	9.37	13.31	12.72	G1/4"	0.98	2.68	1.26	50°	63.8	32
2 1/2"	10"	2 1/2"	7.09	1.19	9.37	14.41	13.62	G1/4"	0.98	3.35	1.61	45°	92.8	34.5
3"	10"	3"	8.27	1.31	9.37	16.02	13.78	G1/4"	0.98	3.94	1.61	45°	-	39

Dimensions in inch

# Angle Seat Valve 7010

pressure balanced version



## Build up, dimensions and weight

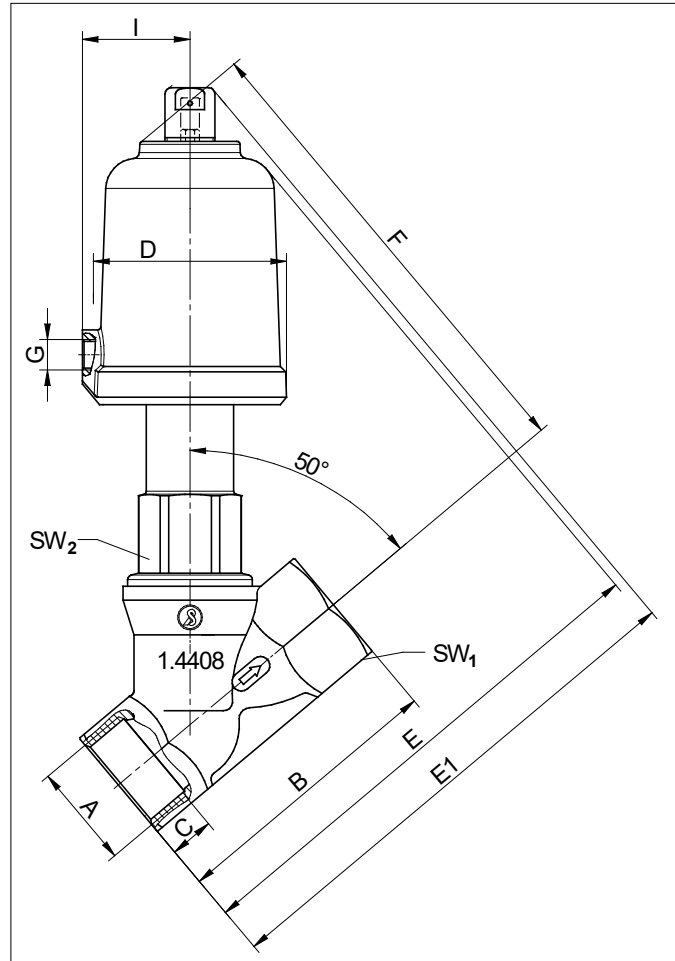
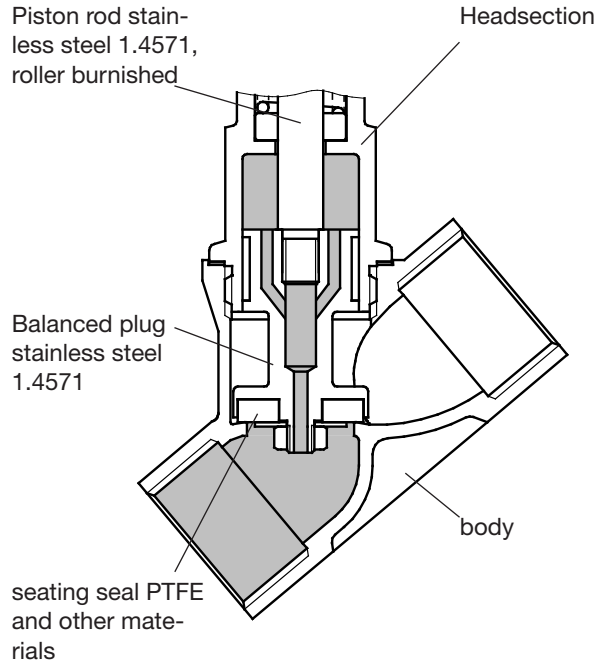

Size	actuator	A G/NPT	B stainless steel	C	D	E stainless steel	F	G	H (stroke)	I	SW1 stainless steel	SW 2 Stand.	Cvs-value stainless steel	weight (kg)
1 1/4"	2"	1 1/4"	4.33	0.84	2.44	6.89	6.5	G1/8"	0.63	1.36	1.89	1.61	24.4	4.4
1 1/2"	2"	1 1/2"	4.72	0.84	2.44	7.28	6.89	G1/8"	0.63	1.36	2.17	1.81	34.8	5.1
1 1/2"	3"	1 1/2"	4.72	0.84	3.78	8.66	8.27	G1/4"	0.83	2.17	2.17	1.81	40.6	9
2"	2"	2"	5.91	1.01	2.44	7.87	7.09	G1/8"	0.63	1.36	2.68	2.05	46.4	7.3
2"	3"	2"	5.91	1.01	3.78	9.45	8.66	G1/4"	0.87	2.17	2.68	2.05	63.8	11
2"	5"	2"	5.91	1.01	5.75	10.43	9.65	G1/4"	0.87	3.15	2.68	2.05	63.8	12.3
2 1/2"	2"	2 1/2"	7.09	1.19	3.78	8.86	7.87	G1/8"	0.63	2.17	3.35	1.42	92.8	11.2
2 1/2"	3"	2 1/2"	7.09	1.19	3.78	10.43	9.45	G1/4"	1.14	2.17	3.35	1.42	92.8	15
2 1/2"	5"	2 1/2"	7.09	1.19	5.75	11.42	10.43	G1/4"	1.14	3.15	3.35	1.42	92.8	17.2
3"	3"	3"	8.43	1.31	3.78	12.8	10.63	G1/4"	1.18	2.17	3.94	1.81	129.9	22.9
3"	5"	3"	8.43	1.31	5.75	13.98	11.81	G1/4"	1.18	3.15	3.94	1.81	129.9	26

Dimensions in inch

# Angle Seat Valve 7010

Version HT220



## Dimensions and weight

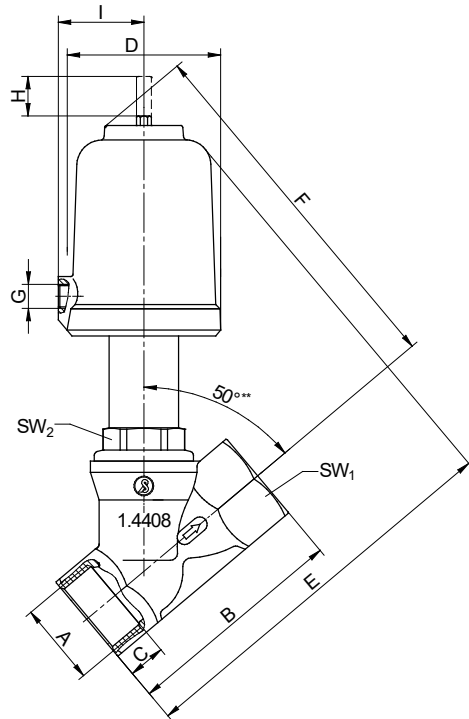

Normally closed

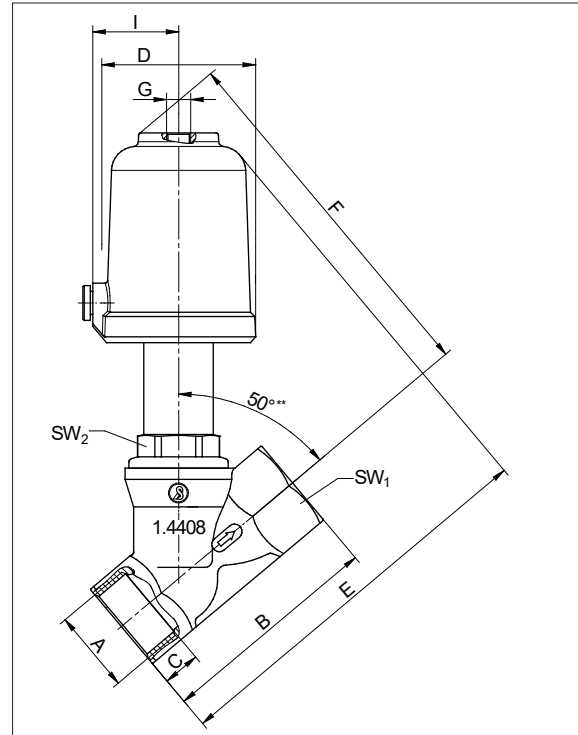

Normally open

Size	Actuator diameter	A G/NPT	B	C	D	E	F	G	H	I	SW1	SW2	Cv-values	Weight (approx. lbs)
3/8"	2"	3/8"	2.35	0.45	2.45	5.6	5.5	G1/8	0.25	1.35	0.9	1.2	1.9	2.4
1/2"	2"	1/2"	2.55	0.6	2.45	5.7	5.45	G1/8	0.3	1.35	1	1.2	4.1	2.6
3/4"	2"	3/4"	2.95	0.65	2.45	6	5.65	G1/8	0.45	1.35	1.2	1.2	9.3	2.9
	3"	3/4"	2.95	0.65	3.8	7.3	7.15	G1/4	0.45	2.15	1.2	1.2	9.3	4.2
1"	3"	1"	3.55	0.75	3.8	7.6	7.3	G1/4	0.65	2.15	1.55	1.2	18.6	6.8
	5"	1"	3.55	0.75	5.75	8.8	8.45	G1/4	0.65	3.15	1.55	1.2	18.6	11.7
1 1/4"	3"	1 1/4"	4.35	0.85	3.8	8.3	7.9	G1/4	0.8	2.15	1.9	1.2	27.8	7.5
	5"	1 1/4"	4.35	0.85	5.75	9.5	9.1	G1/4	0.8	3.15	1.9	1.2	27.8	12.3
1 1/2"	3"	1 1/2"	4.7	0.85	3.8	8.5	8.1	G1/4	0.85	2.15	2.15	1.2	40.6	8.1
	5"	1 1/2"	4.7	0.85	5.75	9.65	9.25	G1/4	0.85	3.15	2.15	1.2	40.6	13
2"	5"	2"	5.9	1	5.75	10.25	9.5	G1/4	1	3.15	2.7	1.25	63.8	14.3
2 1/2"	5"	2 1/2"	7.1	1.2	5.75	11.35	10.35	G1/4	1.15	3.15	3.35	1.4	92.8	15.6

Dimensions in inch

# Angle Seat Valve 7010

## Temperature versions



### Material selection matrix

#### Valves with piston actuator

Version	Description	Fluid temperature	Ambient temperature
1	Standard - Bronze	-22°F up to +338°F	+5°F up to +140°F
2	Standard - Stainless steel	-22°F up to +338°F	+5°F up to +140°F
3	HT220 - version, only with PEEK seating seal	+320°F up to +428°F	+5°F up to +212°F
4	High temperature version in stainless steel		
5	High temperature version for bronze or brass body	-22°F up to +392°F	+5°F up to +212°F
6	Exterior lip seal made of Viton for bronze or brass body	-22°F up to +338°F	
7	Low temperature version acc. to drawing R0194 for stainless steel body		+5°F up to +140°F
8	Low temperature version acc. to drawing R0188 for stainless steel body	-58°F up to +275°F	
9	Low temperature version acc. to drawing R0188 for bronze or brass body		-40°F up to +140°F
10	Low temperature version for stainless steel body		
11	Low temperature version for bronze or brass body	-40°F up to +338°F	+5°F up to +140°F
12	Bonnet for actuator made of polymer for stainless steel body		
13	Bonnet for actuator made of polymer for bronze or brass body	-22°F up to +275°F	+5°F up to +140°F
14	Low temperature version with bonnet for actuator made of polymer and stainless steel body		
15	Low temperature version with bonnet for actuator made of polymer for bronze or brass body	-40°F up to +275°F	+5°F up to +140°F
16	Long head section (without bellows)	-94°F up to +392°F	+5°F up to +140°F
17	Long head section with bellows	-148°F up to +392°F	+5°F up to +140°F
18	Standard, bronze with seals from NBR		
19	Standard, stainless steel with seals from NBR	-22°F up to +338°F	-22°F up to +140°F
20	Low temperature version, seating seal made of NBR and bronze or brass body		
21	Low temperature version, seating seal made of NBR and stainless steel body	-40°F up to +338°F	-40°F up to +140°F

#### Valves with diaphragm actuator

Version	Description	Fluid temperature	Ambient temperature
22	Diaphragm actuator D250	-22°F up to +392°F	-22°F up to +140°F
23	Low temperature version for diaphragm actuator D250	-40°F up to +392°F	-22°F up to +140°F
24	Low temperature version for diaphragm actuator D250 with head section extension	-58°F up to +392°F	-22°F up to +140°F

# Angle Seat Valve 7010

## Body designs

### Body made of stainless steel 1.4408 with female thread G/NPT

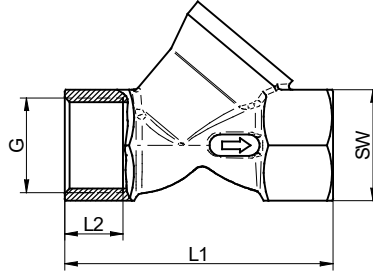

DN	Withworth pipe thread „G“ acc. ISO 228-1 Code: „0“				NPT-thread acc ANSI B 1.20.1 Code: „5“			
	L1	L2	G	SW	L1	L2	G	SW
1/4" (8)	2.36	0.47	G 1/4"	0.79	2.36	0.42	NPT 1/4"	0.79
3/8" (10)	2.36	0.47	G 3/8"	0.91	2.36	0.43	NPT 3/8"	0.91
1/2" (15)	2.56	0.59	G 1/2"	0.98	2.56	0.57	NPT 1/2"	0.98
3/4" (20)	2.95	0.64	G 3/4"	1.22	2.95	0.59	NPT 3/4"	1.22
1" (25)	3.54	0.75	G 1"	1.54	3.54	0.71	NPT 1"	1.54
1 1/4" (32)	4.33	0.84	G 1 1/4"	1.89	4.33	0.73	NPT 1 1/4"	1.89
1 1/2" (40)	4.72	0.84	G 1 1/2"	2.17	4.72	0.73	NPT 1 1/2"	2.17
2" (50)	5.91	1.01	G 2"	2.68	5.91	0.75	NPT 2"	2.68
2 1/2" (65)	7.09	1.19	G 2 1/2"	3.35	7.09	1	NPT 2 1/2"	3.35
3" (80)	8.43	1.32	G 3"	3.94	8.43	1.08	NPT 3"	3.94

Dimensions in inch

### Body made of stainless steel 1.4408 mit conical pipe thread Rc

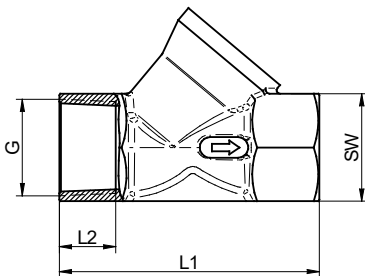

DN	Conical pipe thread „Rc“ acc. EN 10226-2 Code: „T“			
	L1	L2	G	SW
1/4" (8)	-	-	-	-
3/8" (10)	2.36	0.45	Rc 3/8"	0.91
1/2" (15)	2.56	0.59	Rc 1/2"	0.98
3/4" (20)	2.95	0.64	Rc 3/4"	1.22
1" (25)	3.54	0.75	Rc 1"	1.54
1 1/4" (32)	4.33	0.84	Rc 1 1/4"	1.89
1 1/2" (40)	4.72	0.84	Rc 1 1/2"	2.17
2" (50)	5.91	1.01	Rc 2"	2.68

Dimensions in inch

### Body made of stainless steel 1.4408 without thread

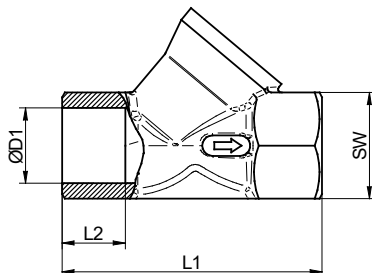

DN	Code: „6“			
	L1	L2	D1	SW
1/4" (8)	2.4	0.65	0.39	0.79
3/8" (10)	2.4	0.65	0.51	0.91
1/2" (15)	2.6	0.65	0.67	0.98
3/4" (20)	2.99	0.73	0.87	1.22
1" (25)	3.58	0.87	1.08	1.54
1 1/4" (32)	4.37	0.94	1.44	1.89
1 1/2" (40)	4.76	0.94	1.67	2.17
2" (50)	5.94	1.14	2.13	2.68
2 1/2" (65)	7.17	1.57	2.6	3.35
3" (80)	8.43	1.52	3.15	3.94

Dimensions in inch

# Angle Seat Valve 7010

## Body designs

### Body made of stainless steel 1.4408 with welding ends DIN/ISO

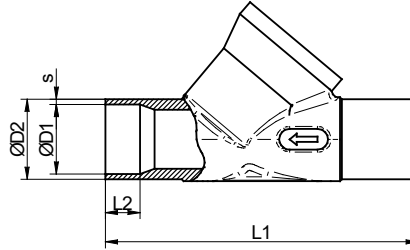

DN	Welding ends acc DIN 11850 series 2 Code: "D"				Welding ends acc ISO 1127 - B Code: "H"			
	L1	L2	D2	s	L1	L2	D2	s
1/4" (8)	-	-	-	-	-	-	-	-
3/8" (10)	-	-	-	-	-	-	-	-
1/2" (15)	3.15	0.79	0.75	0.06	3.15	0.79	0.84	0.08
3/4" (20)	3.54	0.87	0.91	0.06	3.54	0.87	1.06	0.09
1" (25)	3.94	0.83	1.14	0.06	3.94	0.83	1.33	0.1
1 1/4" (32)	4.33	0.79	1.38	0.06	4.33	0.79	1.67	0.1
1 1/2" (40)	4.72	0.87	1.61	0.06	4.72	0.87	1.9	0.1
2" (50)	5.91	1.1	2.09	0.06	5.91	1.1	2.37	0.11
2 1/2" (65)	7.09	1.1	2.76	0.08	7.09	1.1	3	0.11
3" (80)	-	-	-	-	8.66	0.69	3.5	0.13

Dimensions in inch

### Body made of stainless steel 1.4408 with socked-welds

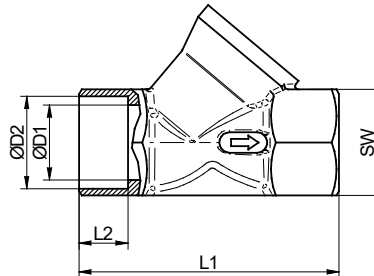

DN	socked-welds acc. R 0103 Code: "2"					socked-welds acc. R 0094 Code: "E"				
	L1	L2	D1	D2	SW	L1	L2	D1	D2	SW
1/4" (8)	-	-	-	-	-	-	-	-	-	-
3/8" (10)	-	-	-	-	-	-	-	-	-	-
1/2" (15)	2.6	0.5	0.67	0.85	0.98	2.6	0.2	0.67	0.81	0.98
3/4" (20)	2.99	0.56	0.87	1.07	1.22	2.99	0.2	0.87	1	1.22
1" (25)	3.58	0.63	1.08	1.33	1.54	3.58	0.2	1.08	1.2	1.54
1 1/4" (32)	4.37	0.69	1.44	1.68	1.89	4.37	0.2	1.44	1.52	1.89
1 1/2" (40)	4.76	0.75	1.67	1.91	2.17	4.76	0.2	1.67	1.77	2.17
2" (50)	5.94	0.87	2.13	2.41	2.68	5.94	0.2	2.13	2.26	2.68
2 1/2" (65)	7.17	0.98	2.6	2.91	3.35	7.17	0.2	2.6	3.02	3.35
3" (80)	8.43	1	3.15	3.53	3.94	8.43	0.2	3.15	3.5	3.94

Dimensions in inch

# Angle Seat Valve 7010

## Body designs

### Body made of stainless steel 1.4408 with welding ends ASME BPE

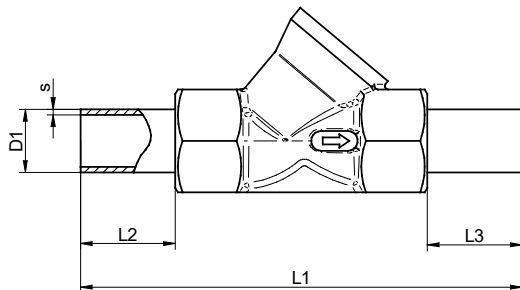

DN	Welding ends acc. R0129 Code: "3"				
	L1	L2	L3	D1	s
1/4" (8)	3.9	0.75	0.75	0.25	0.06
3/8" (10)	-	-	-	-	-
1/2" (15)	4.6	1	1	0.5	0.05
3/4" (20)	5.24	1.13	1.13	0.75	0.06
1" (25)	6.58	1.5	1.5	1	0.06
1 1/4" (32)	-	-	-	-	-
1 1/2" (40)	7.76	1	2	1.5	0.06
2" (50)	8.5	1.28	1.28	2	0.06
2 1/2" (65)	-	-	-	-	-

Dimensions in inch

### Body made of stainless steel 1.4408 with Clamp-connections

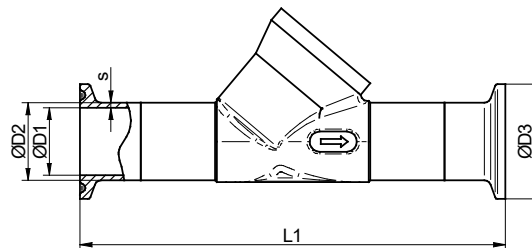

DN	Clamp-connection acc. DIN Code: "N"					Clamp-connection acc. ISO Code: "K"				
	L1	D1	D2	s	D3	L1	D1	D2	s	D3
1/4" (8)	-	-	-	-	-	-	-	-	-	-
3/8" (10)	-	-	-	-	-	-	-	-	-	-
1/2" (15)	4.57	0.63	0.75	0.06	1.34	4.57	0.71	0.84	0.06	1.34
3/4" (20)	4.96	0.79	0.91	0.06	1.34	5.24	0.93	1.06	0.06	1.99
1" (25)	5.63	1.02	1.14	0.06	1.99	5.63	1.17	1.33	0.08	1.99
1 1/4" (32)	6.02	1.26	1.38	0.06	1.99	6.02	1.51	1.67	0.08	1.99
1 1/2" (40)	6.42	1.5	1.61	0.06	1.99	6.42	1.74	1.9	0.08	2.52
2" (50)	7.6	1.97	2.09	0.06	2.52	8.11	2.22	2.37	0.08	3.05
2 1/2" (65)	9.29	2.6	2.76	0.08	3.58	9.29	2.84	3	0.08	3.58
3" (80)	-	-	-	-	-	10.87	3.32	3.5	4.17	0.10

Dimensions in inch

DN	Clamp-connection acc. Inch Code: "Z"			Clamp-connection acc. Inch (long) Code: "Z"		
	L1	D1	D3	L1	D1	D3
1/4" (8)	-	-	-	-	-	-
3/8" (10)	-	-	-	-	-	-
1/2" (15)	4.72	0.37	0.98	-	-	-
3/4" (20)	5.12	0.62	0.98	-	-	-
1" (25)	5.63	0.86	1.99	7.5	0.9	1.99
1 1/4" (32)	6.57	1.12	1.99	-	-	-
1 1/2" (40)	6.42	1.38	1.99	-	-	-
2" (50)	7.6	1.88	2.52	10.5	1.88	2.52
2 1/2" (65)	9.17	2.38	3.05	-	-	-

Dimensions in inch

# Angle Seat Valve 7010

## Body designs

### Body made of stainless steel 1.4408 with welding ends MF

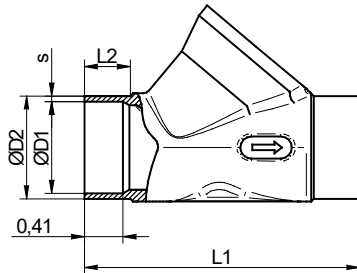

DN	Code: "M"			
	L1	L2	D2	s
1/4" (8)	-	-	-	-
3/8" (10)	-	-	-	-
1/2" (15)	-	-	-	-
3/4" (20)	2.95	0.41	1.1	0.06
1" (25)	-	-	-	-
1 1/4" (32)	-	-	-	-
1 1/2" (40)	-	-	-	-
2" (50)	-	-	-	-
2 1/2" (65)	-	-	-	-

Dimensions in inch

### Body made of stainless steel 1.4408 with male thread

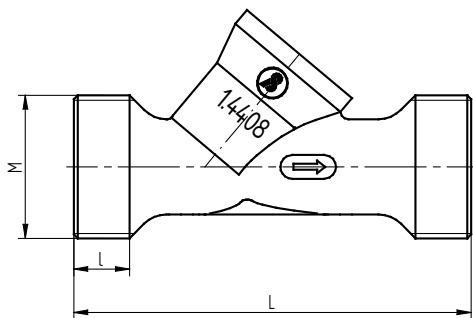

DN	Other special versions Code: „2“		
	M	L	l
1/4" (8)	-	-	-
3/8" (10)	M25x1,5	2.99	0.55
1/2" (15)	-	-	-
3/4" (20)	M36x2	3.94	0.47
1" (25)	-	-	-
1 1/4" (32)	-	-	-
1 1/2" (40)	-	-	-
2" (50)	-	-	-
2 1/2" (65)	-	-	-
3" (80)	-	-	-

Dimensions in inch