

DN 8 up to DN 80; PN 16 - PN 40

Pneumatically operated angle seat valve for the control of neutral, slightly aggressive and highly aggressive media.

- Compact design
- Unaffected by lightly contaminated media
- For temperatures from -100°C up to +220°C
- Working pressure up to 40 bar
- Versatile actuator options



Technical Information

Body material	Brass CC754S	Bronze CC491K	Stainl. steel 1.4408
Nominal size	DN 65 and DN 80	DN 15 to DN 50	DN 8 to DN 80
Connections:			
Pipe thread acc. ISO 228-1	2 1/2" and 3"	1/2" - 2"	1/4" - 3"
NPT thread	2 1/2" and 3"	1/2" - 2"	1/4" - 3"
welding ends (DIN/ISO)			1/2" - 3"
Clamp connections			1/2" - 3"
Nominal pressure	PN 16	PN 16	PN 40
Max. fluid temperature*:			
with metal bonnet	-30°C up to 170°C	-30°C up to 170°C opt. -30°C up to +200°C	-30°C up to 170°C opt. -100°C up to 220°C
with plastic bonnet	-30°C up to 135°C	-30°C up to 135°C	-30°C up to 135°C
diaphragm act., stainless steel			-30°C up to 200°C opt. -30°C up to +220°C
Ambient temperature*	-15°C up to +60°C (versions from -40°C to +100°C possible)		
Vacuum	maximum 0,001 bar abs		
Working pressure	See tables and diagrams, limitation for dangerous gases acc. Pressure equipment directive 2014/68/EU (category I): PS x DN < 1000		
Working pressure for packing underneath	maximum 12 bar		
Working pressure for Tri-Clamp connection	maximum 16 bar		
Packing Leakage	ISO FE BH-CC3-SSA1-t(-30°C, +80°C) Test pressure 40 bar		
Leakage acc. EN 12266-1	leakage class A		

*: Please consider further temperature versions and limits consult the table on page 14

Options and accessories

- Stroke limitation
- Manual emergency operation
- El. position indicator with inductive or mechanical limit switches
- Solenoid valves
- AS-I control head
- Oil- and greasefree version, PTFE-free version, siliconefree version
- Versions for oxygen or ozon applications
- FDA-compliant version
- Version acc. regulation (EG) 1935/2004
- Version approved acc. DIN 161 (automatic shut-off valve for gas burners and gas appliances)
- Offshore-version
- Feedback unit for inductive limit switches
- Version for higher pilot pressures
- Version for under water use
- ...

Angle Seat Valve 7010

Build up and function

Spring closes

The function „spring closes“ may be applied closing against or closing with the flow. In the configuration closing with the flow the valve should only be used for gaseous fluids. If used for liquids, water hammers may occur.

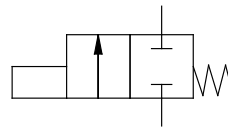

Removable position indicator

Bonnet can be rotated as required (compressed air connection)

Direct pressure control (with a pilot valve if required) actuation by air, water, mineral oil and other media

Head Section

Piston rod stainless steel

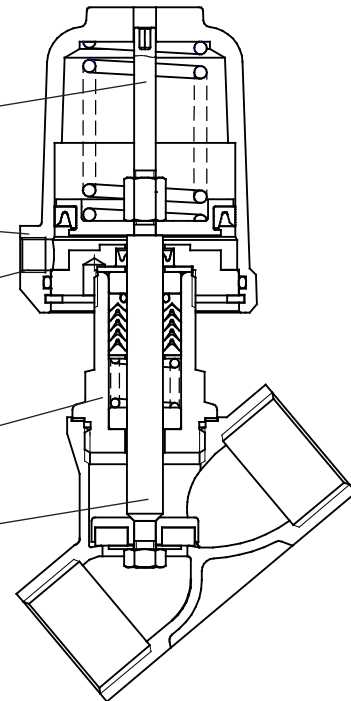

Spring opens

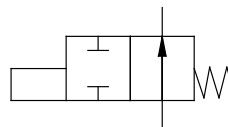

Bonnet material chrome plated brass, plastic, stainless steel or Aluminium

Exterior lip seal

Leak detector

PTFE packing, special version free or (packing underneath)

Seating seal in PTFE or other materials

body with various connection types

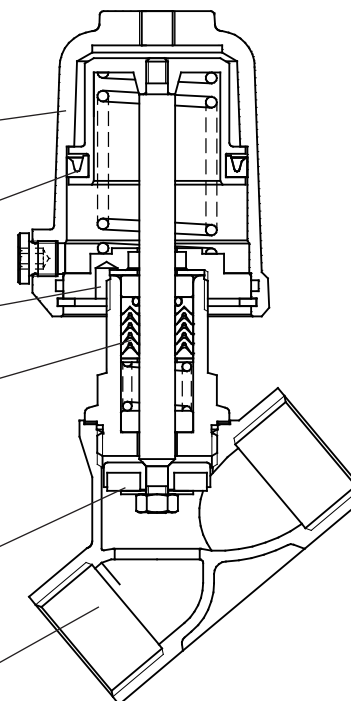

Pilot and operating pressures

Function „spring closes“, closing against flow

Nominal size	Version	Actuator	Springs	Max. differential pressure [bar]				Pilot pressure [bar]
				Red brass	Stainless steel	Stainless steel	Stainless steel	
				PTFE	PTFE	PEEK 7	PEEK 8	
DN8	Standard	D50	1	-	40	40	40	3,5 - 10
DN10	Standard	D50	1	-	40	9,7	36	3,5 - 10
			2	-	40	35	40	4,5 - 10
			3	-	40	40	40	5,7 - 10
DN15	Standard	D50	1	16	21,5	-	17	3,5 - 10
			2	16	34,5	11,5	30	4,5 - 10
			3	16	40	26	40	5,7 - 10
		D80	1	16	40	40	40	3,5 - 10
DN20	Standard	D50	1	6,9	6,9	-	3,7	3,5 - 10
			2	12,5	12,5	-	9,6	4,5 - 10
			3	16	19	2,9	15,5	5,7 - 10
		D80	1	16	40	25	38	3,5 - 10
			2	16	40	38,5	40	4,4 - 10
			3	16	40	40	40	5,6 - 10
DN25	Standard	D50	1	2,4	2,4	-	-	3,5 - 10
			2	5,7	5,7	-	3,2	4,5 - 10
			3	9,1	9,1	-	6,6	5,7 - 10
		D80	1	16	22	9,9	19,5	3,5 - 10
			2	16	30	17,5	27,5	4,4 - 10
			3	16	39	27	36,5	5,6 - 10
		D125	1	16	19	6,7	16,5	1,3 - 10
			2	16	40	28	38	2,3 - 10
			3	16	40	40	40	3,1 - 10
DN32	Standard	D50	1	1	1	-	-	3,5 - 10
			2	3,1	3,1	-	1,1	4,5 - 10
			3	5,1	5,1	-	3,1	5,7 - 10
		D80	1	12,5	12,5	2,7	10,5	3,5 - 10
			2	16	17	7,3	15	4,4 - 10
			3	16	22	12,5	20,5	5,6 - 10
		D125	1	10,5	10,5	1,1	8,9	1,3 - 10
			2	16	23,5	14	21,5	2,3 - 10
			3	16	33,5	24	31,5	3,1 - 10
	D250	4	16	39	29,5	37	4,0 - 10	
		8	-	40	40	40	2,7 - 6	
		2	-	40	-	40	4,5 - 10	
pressure balanced	D80	1	-	40	40	40	3,5 - 10	
	2	-	40	40	40	4,4 - 10		
DN40	Standard	D50	2	1,9	1,9	-	-	4,5 - 10
			3	3,3	3,3	-	1,6	5,7 - 10
			1	7,9	7,9	-	6,2	3,5 - 10
		D80	2	11	11	2,8	9,3	4,4 - 10
			3	14	14	6,2	12,5	5,6 - 10
			1	7	7	-	5,3	1,3 - 10
		D125	2	15,5	15,5	7,4	14	2,3 - 10
			3	16	22	14	20,5	3,1 - 10
			4	-	25	16,5	23,5	4,0 - 10
	d16	D250	8	-	32	24	30	2,7 - 6
		12	-	40	36,5	40	3,7 - 6	
		1	-	34,5	-	-	3,5 - 10	
	pressure balanced	D50	2	-	40	-	19	4,5 - 10
			3	-	40	-	40	5,7 - 10
			1	-	40	-	40	3,5 - 10
		D80	2	-	40	40	40	4,4 - 10

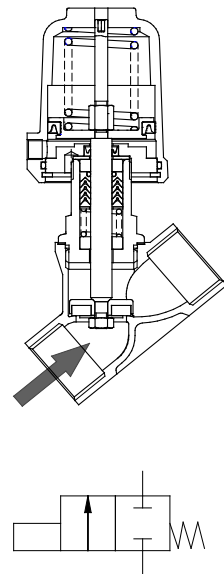

= Standard spring configuration

d16: reinforced design with 16mm piston rod

PEEK 7: Seating seal made of PEEK for use below 160°C

PEEK 8: Seating seal made of PEEK for use above 160°C

For soft seals such as EPDM, FKM, NBR or Vulkolan the same values as with PTFE are valid

Pilot and operating pressures

Function „spring closes“, closing against flow

Nominal size	Version	Actuator	Springs	Max. differential pressure [bar]				Pilot pressure [bar]	
				Red brass	Stainless steel	Stainless steel	Stainless steel		
Body material				PTFE	PTFE	PEEK 7	PEEK 8		
Seating seal									
DN50	Standard	D50	2	1	1	-	-	4,5 - 10	
			3	1,9	1,9	-	-	5,7 - 10	
		D80	1	4,1	4,1	-	2,8	3,5 - 10	
			2	5,9	5,9	-	4,6	4,4 - 10	
		D125	3	7,8	7,8	1,2	6,5	5,6 - 10	
			1	3,8	3,8	-	2,5	1,3 - 10	
	d16	D125	2	9	9	2,4	7,6	2,3 - 10	
			3	12,5	12,5	6	11	3,1 - 10	
		D250	3	-	12,5	6	11	3,2 - 10	
			4	-	13	6,8	12	4,0 - 10	
		D250	8	-	19,5	13	18	2,7 - 6	
			12	-	27,5	21	26	3,7 - 6	
	pressure balanced	D50	2	-	31,5	-	-	4,5 - 10	
			3	-	40	-	-	5,7 - 10	
		D80	2	-	40	11	40	4,4 - 10	
			3	-	40	40	40	5,6 - 10	
		D125	2	-	40	40	40	2,3 - 10	
			3	-	40	40	40	2,3 - 10	
DN65	Standard	D80	3	4,1 *	4,2	-	3,2	5,6 - 10	
			1	1,7 *	1,9	-	-	1,3 - 10	
		D125	2	4,8 *	4,8	-	3,9	2,3 - 10	
			3	6,8 *	7	2	6	3,1 - 10	
		d16	D125	3	-	7	2	6	3,1 - 10
	4			-	7,5	2,5	6,5	4,0 - 10	
	D250		8	-	11	6	10	2,7 - 6	
			12	-	15	10	14	3,7 - 6	
	pressure balanced		D50	2	-	21	-	-	4,5 - 10
		2		-	25	-	25	4,4 - 10	
		D80	2	-	25	-	25	2,3 - 10	
			3	-	25	25	25	3,1 - 10	
		DN80	Standard	D80	3	2,6 *	**	**	**
	1				1,1 *	**	**	**	1,3 - 10
	D125			2	3,0 *	**	**	**	2,3 - 10
3				4,9 *	**	**	**	3,1 - 10	
d16	D125		3	-	4,7	-	3,9	3,2 - 10	
			4	-	5	-	4,2	4,0 - 10	
	D250		8	-	7,5	3,4	6,7	2,7 - 6	
			12	-	10,5	6,4	9,7	3,7 - 6	
pressure balanced	D80		2	-	25	-	18	4,6 - 10	
			3	-	25	-	25	5,6 - 10	
	D125		2	-	25	-	25	2,3 - 10	
			3	-	25	6,1	25	3,2 - 10	

= Standard spring configuration

* brass body

** only in reinforced design d16

d16: reinforced design with 16mm piston rod

PEEK 7: Seating seal made of PEEK for use below 160°C

PEEK 8: Seating seal made of PEEK for use above 160°C

For soft seals such as EPDM, FKM, NBR or Vulkolan the same values as with PTFE are valid

Angle Seat Valve 7010

Pilot and operating pressures

Function „spring opens“, closing against flow

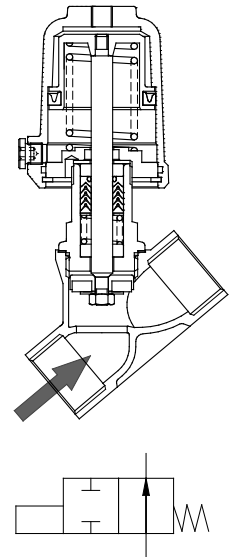

Seating seal PTFE, EPDM, FKM, NBR or Vulkolan

Nominal size	Version	Actuator	Max. differential pressure [bar] at available pilot pressure [bar]																
			2	2,5	3	3,5	4	4,5	5	5,5	6	6,5	7	7,5	8	8,5	9	9,5	10
DN08	Standard	D50	0	2,8	30	40	40	-	-	-	-	-	-	-	-	-	-	-	-
DN10	Standard	D50	0	0	13,5	28	40	40	-	-	-	-	-	-	-	-	-	-	-
DN15	Standard	D50	0	0	6,6	13,5	20,5	27,5	34,5	40	40	-	-	-	-	-	-	-	-
		D80	40	40	-	-	-	-	-	-	-	-	-	-	-	-	-	-	-
DN20	Standard	D50	0	0	0,6	4,1	7,6	11	14,5	18	21	24,5	28	31,5	35	38,5	40	40	-
		D80	19,5	28,5	37,5	40	-	-	-	-	-	-	-	-	-	-	-	-	-
DN25	Standard	D50	0	0	0	1,2	3,3	5,3	7,4	9,5	11,5	13,5	15,5	17,5	19,5	21,5	23,5	26	28
		D80	10	15,5	21	26,5	32	37,5	40	40	-	-	-	-	-	-	-	-	-
DN32	Standard	D50	0	0	0	0,3	1,6	2,8	4,1	5,4	6,7	8	9,3	10,5	11,5	13	14	15,5	16,5
		D80	5,6	9	12	15,5	19	22,5	25,5	29	32,5	35,5	39	40	-	-	-	-	-
		D125	24,5	32,5	40	-	-	-	-	-	-	-	-	-	-	-	-	-	-
DN40	Standard	D50	0	0	0	0	0,8	1,7	2,6	3,5	4,4	5,3	6,2	7,1	8	8,9	9,8	10,5	11,5
		D80	3,4	5,8	8,1	10,5	12,5	15	17,5	19,5	22	24,5	26,5	29	31,5	34	36	38,5	40
		D125	16,5	22	28	34	29,5	40	-	-	-	-	-	-	-	-	-	-	-
DN50	Standard	D50	0	0	0	0	0,3	0,8	1,4	2	2,6	3,2	3,7	4,3	4,9	5,5	6	6,6	7,2
		D80	1,7	3,2	4,7	6,2	7,7	9,2	10,5	12	13,5	15	16,5	18	19,5	21	22,5	24	25,5
		D125	10	13,5	17,5	21	25	28,5	32,5	36	40	-	-	-	-	-	-	-	-
DN65	Standard	D80	0,6	1,5	2,4	3,2	4,1	4,9	5,8	6,7	7,5	8,4	9,2	10	10,5	11,5	12,5	13,5	14
	D125	5,5	7,6	9,7	11,5	14	16	17	20	22	24,5	25	-	-	-	-	-	-	
	d16	D125	5,4	7,5	9,6	11,5	13,5	15,5	18	20	22	24	25	-	-	-	-	-	
DN80	Standard *	D80	0,3	0,9	1,5	2,1	2,7	3,3	3,9	4,5	5,1	5,7	6,3	6,9	7,5	8,1	8,7	9,3	9,9
		D125	3,7	5,2	6,6	8,1	9,6	11	12,5	14	15,5	16	-	-	-	-	-	-	
		D125	3,6	5,1	6,5	8	9,5	10,5	12	13,5	15	16,5	18	19,5	21	22,5	24	25	-

* brass body

d16: reinforced design with 16mm piston rod

Actuator D50: max. pilot pressure 1 bar above the required pilot pressure

Actuator D80: max. pilot pressure 0,8 bar above the required pilot pressure

Actuator D125 and D250: max. pilot pressure 0,5 bar above the required pilot pressure

Pilot and operating pressures

Function „spring opens“, closing against flow

Seating seal PEEK-8

Nominal size	Version	Actuator	Max. differential pressure [bar] at available pilot pressure [bar]																
			2	2,5	3	3,5	4	4,5	5	5,5	6	6,5	7	7,5	8	8,5	9	9,5	10
DN08	Standard	D50	0	0	21	40	40	-	-	-	-	-	-	-	-	-	-	-	-
DN10	Standard	D50	0	0	6,9	21	35,5	40	40	-	-	-	-	-	-	-	-	-	-
DN15	Standard	D50	0	0	2	9	16	23	30	37	40	40	-	-	-	-	-	-	-
		D80	39,5	40	-	-	-	-	-	-	-	-	-	-	-	-	-	-	-
DN20	Standard	D50	0	0	0	0,9	4,3	7,8	11	14,5	18	21,5	25	28,5	32	35,5	39	40	40
		D80	16	25	34	40	40	-	-	-	-	-	-	-	-	-	-	-	-
DN25	Standard	D50	0	0	0	0	0,8	2,9	4,9	7	9	11	13	15	17	19	21	23,5	25,5
		D80	7,9	13	18,5	24	29,5	35	40	40	-	-	-	-	-	-	-	-	-
DN32	Standard	D50	0	0	0	0	0,9	2,2	3,4	4,7	6	7,3	8,6	9,9	11	12	13,5	15	
		D80	3,7	7	10	13,5	17	20,5	23,5	27	30,5	34	37	40	40	-	-	-	-
		D125	22,5	30,5	39	40	-	-	-	-	-	-	-	-	-	-	-	-	-
DN40	Standard	D80	1,8	4,1	6,5	8,8	11	13,5	15,5	18	20,5	23	25	27,5	30	32	34,5	37	39
		D125	15	20,5	26,5	32	38	40	-	-	-	-	-	-	-	-	-	-	-
DN50	Standard	D80	0,3	1,9	3,4	4,9	6,4	7,9	9,4	11	12,5	14	15,5	17	18,5	20	21,5	23	24,5
		D125	8,8	12,5	16	20	23,5	27,5	31	35	38,5	40	-	-	-	-	-	-	-
DN65	Standard	D80	0	0,6	1,4	2,3	3,1	4	4,8	5,7	6,6	7,4	8,3	9,1	10	10,5	11,5	12,5	13
		D125	4,5	6,6	8,7	10,5	13	15	17	19	21	23,5	25	-	-	-	-	-	-
	d16	D250	5	9,3	13,5	18	22	25	-	-	-	-	-	-	-	-	-	-	-
DN80	d16	D80	0	0	0,5	1,1	1,7	2,3	2,9	3,5	4	4,6	5,2	5,8	6,4	6,9	7,5	8,1	8,7
		D125	2,8	4,3	5,7	7,2	8,6	10	11,5	13	14,5	15,5	17	18,5	20	21,5	23	24,5	25
		D250	3,2	6,2	9,2	12	15	18	21	24	25	-	-	-	-	-	-	-	-

Seating seal PEEK-7

Nominal size	Version	Actuator	Max. differential pressure [bar] at available pilot pressure [bar]																
			2	2,5	3	3,5	4	4,5	5	5,5	6	6,5	7	7,5	8	8,5	9	9,5	10
DN08	Standard	D50	0	0	0	12	40	40	-	-	-	-	-	-	-	-	-	-	-
DN10	Standard	D50	0	0	0	0	9,5	24	38,5	40	40	-	-	-	-	-	-	-	-
DN15	Standard	D50	0	0	0	0	0	4,7	11,5	18,5	25,5	32,5	39,5	40	40	-	-	-	-
		D80	21,5	39,5	40	-	-	-	-	-	-	-	-	-	-	-	-	-	-
DN20	Standard	D50	0	0	0	0	0	0	1,8	5,3	8,8	12	15,5	19	22,5	26	29,5	33	
		D80	3,3	12	21,5	30,5	39,5	40	-	-	-	-	-	-	-	-	-	-	-
DN25	Standard	D80	0	3,3	8,8	14	19,5	25	30,5	35,5	40	40	-	-	-	-	-	-	-
		D125	28	40	-	-	-	-	-	-	-	-	-	-	-	-	-	-	-
DN32	Standard	D80	0	0	2,6	5,9	9,3	12,5	16	19	22,5	26	29,5	32,5	36	39,5	40	-	-
		D125	14,5	23	31	39,5	40	-	-	-	-	-	-	-	-	-	-	-	-
DN40	Standard	D80	0	0	0	2,3	4,6	7	9,3	11,5	14	16	18,5	21	23,5	25,5	28	30,5	32,5
		D125	8,4	14	20	25,5	31,5	37	40	-	-	-	-	-	-	-	-	-	-
DN50	Standard	D80	0	0	0	0	1,1	2,7	4,2	5,7	7,2	8,7	10	11,5	13	14,5	16	17,5	19
		D125	3,6	7,3	11	14,5	18,5	22	26	29,5	33	37	40	-	-	-	-	-	-
		D250	4,5	12	19,5	27	35	40	-	-	-	-	-	-	-	-	-	-	-
DN65	Standard	D125	0,5	2,7	4,8	6,9	9	11	13	15	17,5	19,5	21,5	23,5	25	-	-	-	-
		D250	1	5,4	9,7	14	18	22,5	25	-	-	-	-	-	-	-	-	-	-
DN80	d16	D125	0	0,9	2,4	3,9	5,3	6,8	8,2	9,7	11	12,5	14	15,5	17	18	19,5	21	22,5
		D250	0	2,9	5,9	8,9	12	15	18	21	24	-	-	-	-	-	-	-	-

d16: reinforced design with 16mm piston rod

PEEK 7: Seating seal made of PEEK for use below 160°C

PEEK 8: Seating seal made of PEEK for use above 160°C

Actuator D50: max. pilot pressure 1 bar above the required pilot pressure

Actuator D80: max. pilot pressure 0,8 bar above the required pilot pressure

Actuator D125 and D250: max. pilot pressure 0,5 bar above the required pilot pressure

Angle Seat Valve 7010

Pilot and operating pressures

Function „spring closes“, closing with flow

- Angled seat valve closing with the flow, spring closes
- Use preferably for gaseous fluids
- With liquids waterhammers are possible

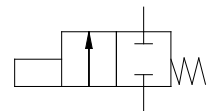
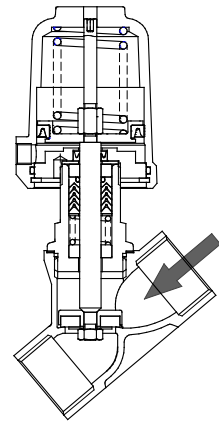

Seating seal PTFE, EPDM, FKM, NBR or Vulkolan

Nominal Size	Version	Actuator	Max. differential pressure [bar] at available pilot pressure [bar]																
			2	2,5	3	3,5	4	4,5	5	5,5	6	6,5	7	7,5	8	8,5	9	9,5	10
DN08	Standard	D50	0	0	40	40	40	40	40	40	40	40	40	40	40	40	40	40	40
DN10	Standard	D50	0	0	40	40	40	40	40	40	40	40	40	40	40	40	40	40	40
DN15	Standard	D50	0	0	21,5	38,5	40	40	40	40	40	40	40	40	40	40	40	40	40
DN20	Standard	D50	0	0	8,7	13,5	18	23	28	33	37,5	40	40	40	40	40	40	40	40
		D80	25,5	38,5	40	40	40	40	40	40	40	40	40	40	40	40	40	40	40
DN25	Standard	D50	0	0	5,2	7,7	10	12,5	15	17,5	20	22,5	25	27,5	30	32,5	33	33	33
		D80	13,5	20	26,5	33	33	33	33	33	33	33	33	33	33	33	33	33	33
DN32	Standard	D50	0	0	3	4,4	5,9	7,3	8,7	10	11,5	13	14,5	15,5	17	18,5	19	19	19
		D80	8	11,5	15,5	19	23	26,5	30,5	34	35	35	35	35	35	35	35	35	35
		D125	28,5	35	35	35	35	35	35	35	35	35	35	35	35	35	35	35	35
DN40	Standard	D50	0	0	0	2,4	3,4	4,3	5,3	6,3	7,2	8,2	9,2	10	11	12	13	13	13
		D80	0	5,1	7,7	10	12,5	15	17,5	20	22,5	23	23	23	23	23	23	23	23
		D125	12,5	18,5	23	23	23	23	23	23	23	23	23	23	23	23	23	23	23
	d16	D125	12	18,5	24,5	30,5	37	40	40	40	40	40	40	40	40	40	40	40	
DN50	Standard	D50	0	0	0	1,4	2	2,6	3,2	3,9	4,5	5,1	5,7	6,3	6,9	7,5	8	8	8
		D80	0	3,6	5,2	6,8	8,4	10	11,5	13	14,5	15	15	15	15	15	15	15	15
		D125	8,3	12	15	15	15	15	15	15	15	15	15	15	15	15	15	15	15
		d16	D125	8,1	12	15,5	19,5	23,5	27,5	31	35	38	38	38	38	38	38	38	38
DN65	Standard	D80	0	2	2,9	3,7	4,6	5,5	6,4	7,3	8,1	9	9,9	10,5	11,5	12	12	12	
		D125	4,6	6,7	8,9	11	12	12	12	12	12	12	12	12	12	12	12	12	
	d16	D125	4,5	6,6	8,8	10,5	13	15	17	19,5	20	20	20	20	20	20	20	20	
DN80	Standard *	D80	0	1,3	2	2,6	3,2	3,8	4,44	5	5,6	6,2	6,8	7,4	8	8,7	9	9	
		D125	3,1	4,6	6,1	7,6	9	9	9	9	9	9	9	9	9	9	9	9	
	d16	D80	0	0	0	0	1,8	2,4	3	3,6	4,2	4,8	5,4	6	6,6	7,2	7,8	8,4	
		D125	3,1	4,6	6	7,5	9	10,5	12	13	13	13	13	13	13	13	13	13	
		D250	0	7,9	11	13	13	13	13	13	13	-	-	-	-	-	-		

* brass body

d16: reinforced design with 16mm piston rod

Pilot and operating pressures

Function „spring closes“, closing with flow

Seating seal PEEK-8

Nominal Size	Version	Actuator	Springs	Max. differential pressure [bar] at available pilot pressure [bar]																	
				2	2,5	3	3,5	4	4,5	5	5,5	6	6,5	7	7,5	8	8,5	9	9,5	10	
DN08	Standard	D50	1	0	0	40	40	40	40	40	40	40	40	40	40	40	40	40	40	40	
DN10	Standard	D50	1	0	0	40	40	40	40	40	40	40	40	40	40	40	40	40	40	40	40
DN15	Standard	D50	2	0	0	0	0	4	20,5	37,5	40	40	40	40	40	40	40	40	40	40	40
DN20	Standard	D50	2	0	0	0	1,1	6	10,5	15,5	20,5	25,5	30	35	40	40	40	40	40	40	40
		D80	1	0	0	1,8	14,5	27	40	40	40	40	40	40	40	40	40	40	40	40	40
		D125	1	40	40	40	40	40	40	40	40	40	40	40	40	40	40	40	40	40	40
DN25	Standard	D50	2	0	0	0	2,1	4,6	7,1	9,6	12	14,5	17	19,5	22	24,5	27	29,5	32	33	33
		D80	1	0	0	2,8	9,4	15,5	22,5	29	33	33	33	33	33	33	33	33	33	33	33
		D125	1	30	33	33	33	33	33	33	33	33	33	33	33	33	33	33	33	33	33
DN32	Standard	D50	2	0	0	0	1,3	2,7	4,1	5,6	7	8,5	9,9	11	12,5	14	15,5	17	18,5	19	19
		D80	1	0	0	2,6	6,4	10	13,5	17,5	21,5	25	29	32,5	35	35	35	35	35	35	35
		D125	1	18	27	35	35	35	35	35	35	35	35	35	35	35	35	35	35	35	35
DN40	Standard	D80	1	0	0	2,4	5	7,5	10	12,5	15	17,5	20	22,5	23	23	23	23	23	23	23
		D125	2	3,2	9,5	15,5	22	23	23	23	23	23	23	23	23	23	23	23	23	23	23
	d16	D125	2	3	9,2	15	21,5	27,5	34	40	40	40	40	40	40	40	40	40	40	40	40
DN50	Standard	D80	2	0	0	0,3	1,9	3,5	5,1	6,7	8,2	9,8	11	13	14,5	15	15	15	15	15	15
		D125	2	2,9	6,8	10,5	14,5	15	15	15	15	15	15	15	15	15	15	15	15	15	15
	d16	D125	2	2,7	6,6	10,5	14	18	22	26	29,5	33,5	37,5	38	38	38	38	38	38	38	38
		D250	6	12,5	20,5	28,5	36,5	38	38	38	38	38	-	-	-	-	-	-	-	-	-
DN65	Standard	D125	2	1,5	3,7	5,9	8	10	12	12	12	12	12	12	12	12	12	12	12	12	
	d16	D125	2	1,4	3,6	5,7	7,9	10	12	14	16,5	18,5	20	20	20	20	20	20	20	20	
		D250	6	7,1	11,5	16	20	20	20	20	20	20	-	-	-	-	-	-	-	-	
DN80	d16	D125	2	1	2,5	3,9	5,4	6,9	8,4	9,9	11	12,5	13	13	13	13	13	13	13	13	
		D250	6	4,9	7,9	11	13	13	13	13	13	13	-	-	-	-	-	-	-	-	

Seating seal PEEK-7

Nominal Size	Version	Actuator	Springs	Max. differential pressure [bar] at available pilot pressure [bar]																	
				2	2,5	3	3,5	4	4,5	5	5,5	6	6,5	7	7,5	8	8,5	9	9,5	10	
DN08	Standard	D50	1	0	0	40	40	40	40	40	40	40	40	40	40	40	40	40	40	40	40
DN10	Standard	D50	1	0	0	40	40	40	40	40	40	40	40	40	40	40	40	40	40	40	40
DN15	Standard	D50	2	0	0	0	0	4	20,5	37,5	40	40	40	40	40	40	40	40	40	40	40
DN20	Standard	D80	1	0	0	1,8	14,5	27	40	40	40	40	40	40	40	40	40	40	40	40	40
		D125	1	40	40	40	40	40	40	40	40	40	40	40	40	40	40	40	40	40	40
DN25	Standard	D80	1	0	0	2,8	9,4	15,5	22,5	29	33	33	33	33	33	33	33	33	33	33	33
		D125	1	30	33	33	33	33	33	33	33	33	33	33	33	33	33	33	33	33	33
DN32	Standard	D80	2	0	0	0	1,2	5	8,8	12,5	16	20	23,5	27,5	31	35	35	35	35	35	35
		D125	1	18	27	35	35	35	35	35	35	35	35	35	35	35	35	35	35	35	35
DN40	Standard	D80	2	0	0	0	0,8	3,3	5,8	8,3	10,5	13	15,5	18	20,5	23	25,5	28	30,5	33	33
		D125	2	3,2	9,5	15,5	22	23	23	23	23	23	23	23	23	23	23	23	23	23	23
	d16	D125	2	3	9,2	15	21,5	27,5	34	40	40	40	40	40	40	40	40	40	40	40	40
DN50	Standard	D125	2	2,9	6,8	10,5	14,5	15	15	15	15	15	15	15	15	15	15	15	15	15	15
		D125	2	2,7	6,6	10,5	14	18	22	26	29,5	33,5	37,5	38	38	38	38	38	38	38	38
	d16	D250	6	12,5	20,5	28,5	36,5	38	38	38	38	38	-	-	-	-	-	-	-	-	
DN65	Standard	D125	3	0	1,5	3,7	5,9	8	10	12	12	12	12	12	12	12	12	12	12	12	
		D125	3	0	1,4	3,6	5,7	7,9	10	12	14	16,5	18,5	20	20	20	20	20	20	20	
	d16	D250	6	7,1	11,5	16	20	20	20	20	20	20	20	20	20	20	20	20	20	20	
DN80	d16	D125	2	0	1	2,5	3,9	5,4	6,9	8,4	9,9	11	12,5	13	13	13	13	13	13	13	
		D250	6	4,9	7,9	11	13	13	13	13	13	13	-	-	-	-	-	-	-		

d16: reinforced design with 16mm piston rod
 PEEK 7: Seating seal made of PEEK for use below 160°C
 PEEK 8: Seating seal made of PEEK for use above 160°C

Angle Seat Valve 7010

standard design

Dimensions and Weights

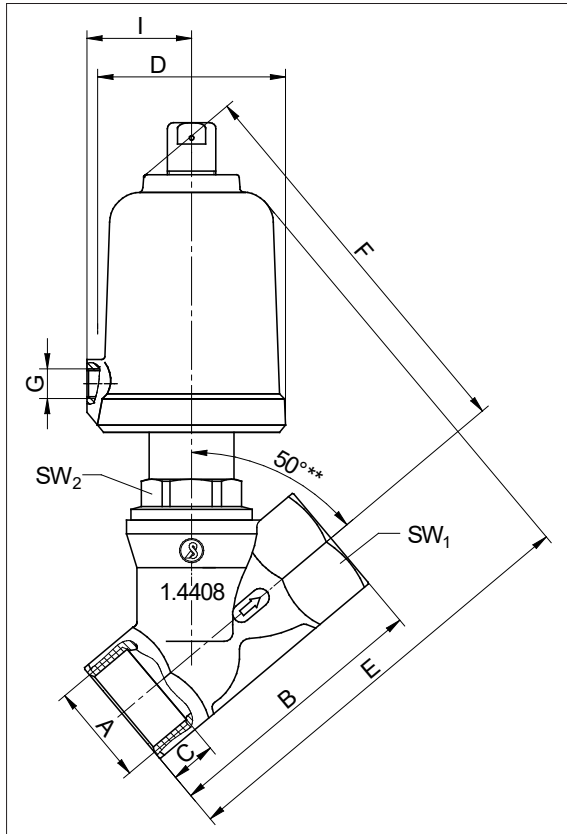

Normally closed

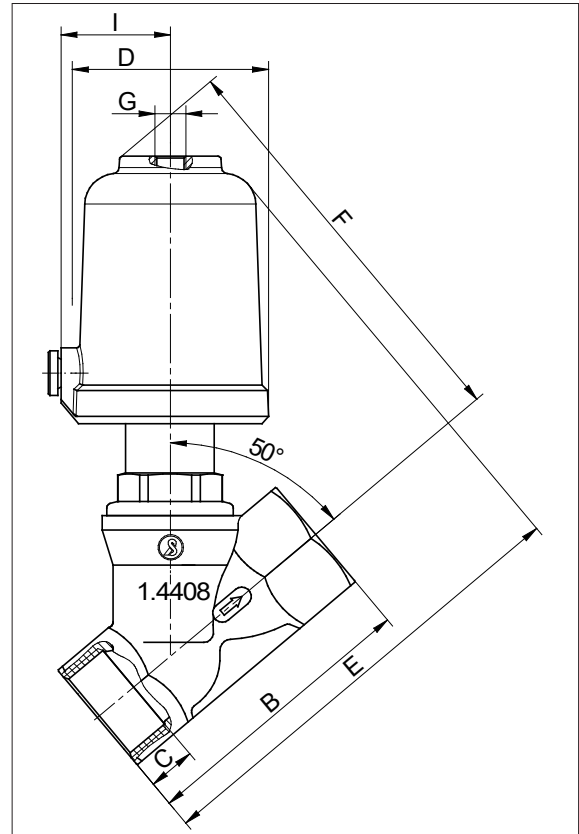

Normally open

** <= 45° for DN65, brass body for DN80 and stainless steel body for DN80

DN	actuator	A G/ NPT	B		C	D	E		F	G	H (stroke)	I	SW1		SW 2		Kvs-values		Weight (kg)
			bronze stainl. steel*	brass			bronze stainl. steel*	brass					bronze stainl. steel*	brass	standard	reinforced	bronze stainl. steel*	brass	
8	D50	1/4"	60	-	12	62	130	-	123	G1/8"	8,5	34,5	20	-	30	-	0,95	-	1
10	D50	3/8"	60	-	12	62	130	-	123	G1/8"	9	34,5	23	-	30	-	1,6	-	1,05
15	D50	1/2"	65	-	15	62	135	-	120	G1/8"	7	34,5	25	-	30	-	3,5	-	1,1
20	D50	3/4"	75	-	16,3	62	135	-	125	G1/8"	12	34,5	31	-	30	-	8	-	1,2
25	D50	1"	90	-	19,1	62	145	-	130	G1/8"	16	34,5	39	-	30	-	15	-	1,4
	D80	1"	90	-	19,1	96	185	-	170	G1/4"	16	55	39	-	30	-	16	-	3
32	D50	1 1/4"	110	-	21,4	62	160	-	145	G1/8"	16	34,5	48	-	30	-	21	-	1,8
	D80	1 1/4"	110	-	21,4	96	200	-	190	G1/4"	20	55	48	-	30	-	24	-	3,3
40	D125	1 1/4"	110	-	21,4	146	230	-	215	G1/4"	20	80	48	-	30	-	24	-	5,5
	D50	1 1/2"	120	-	21,4	62	165	-	150	G1/8"	16	34,5	55	-	30	-	30	-	2,1
	D80	1 1/2"	120	-	21,4	96	205	-	195	G1/4"	23	55	55	-	30	-	35	-	3,6
50	D125	1 1/2"	120	-	21,4	146	235	-	220	G1/4"	23	80	55	-	30	-	35	-	5,8
	D50	2"	150	-	25,7	62	185	-	160	G1/8"	16	34,5	68	-	32	-	40	-	2,7
	D80	2"	150	-	25,7	96	225	-	200	G1/4"	29	55	68	-	32	36	55	-	4,2
65	D125	2"	150	-	25,7	146	250	-	225	G1/4"	29	80	68	-	32	36	55	-	6,4
	D80	2 1/2"	180	180	30,2	96	260	260	220	G1/4"	29	55	85	85	36	41	80	93	6,2
	D125	2 1/2"	180	180	30,2	146	285	285	250	G1/4"	29	80	85	85	36	41	80	93	8,4
80	D80	3"	214	210	33,3	96	290	280	225	G1/4"	29	55	100	100	41	41	112	115	8,3
	D125	3"	214	210	33,3	146	315	305	250	G1/4"	29	80	100	100	41	41	112	115	10,5

*Dimensions in accordance with DIN 3202 T4 M8
Dimensions in mm

Angle Seat Valve 7010

reinforced design with diaphragm actuator

Dimensions and Weights

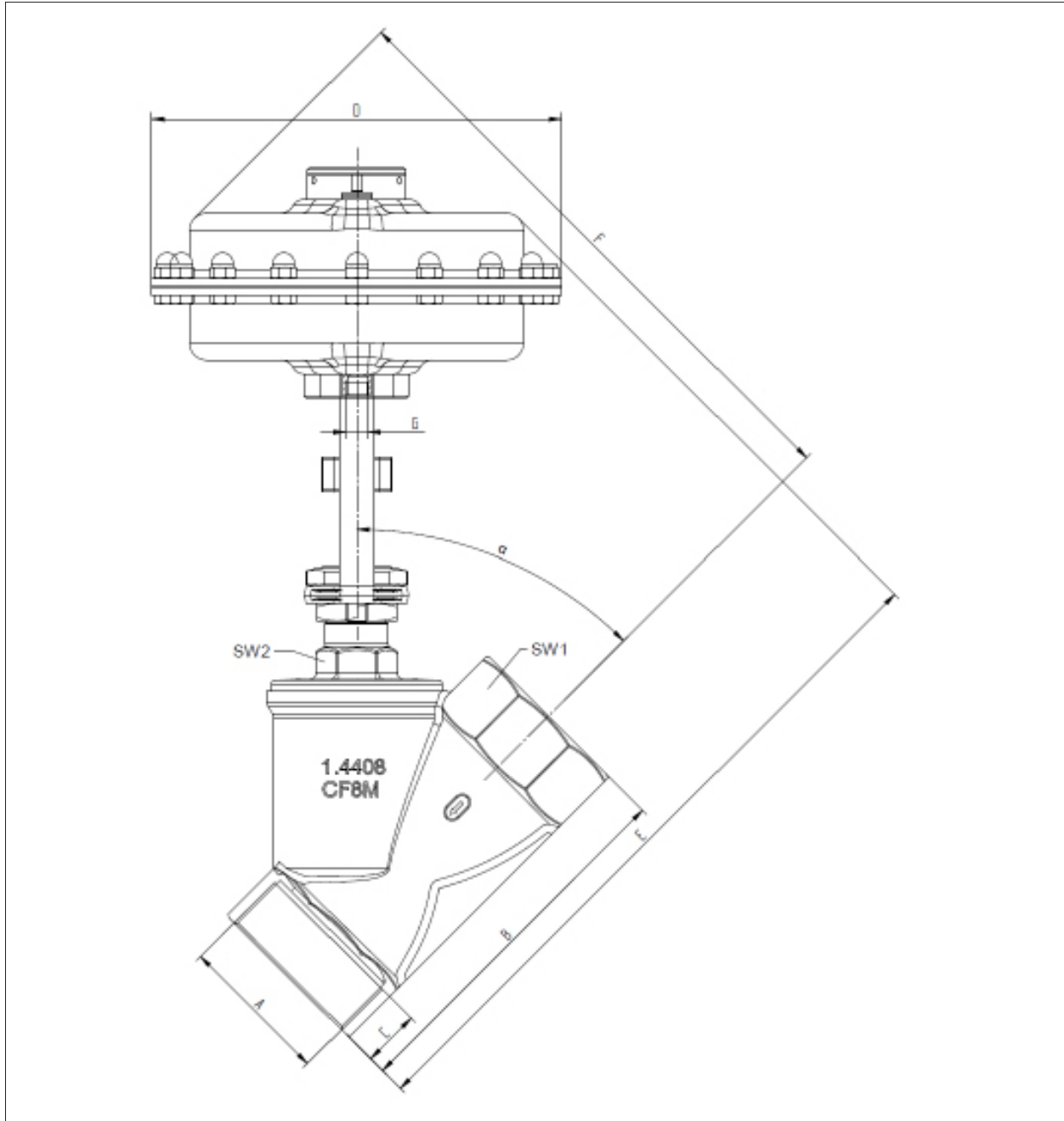

DN	Actuator	A Rp/ NPT	B*	C	D	E	F	G	Stroke (mm)	SW1	SW2	α	Kvs- value	Weight (kg)
50	D250	2"	150	25,7	238	338	323	G1/4"	25	68	32	50°	55	14,6
65	D250	2 1/2"	180	30,2	238	366	346	G1/4"	25	85	41	45°	80	15,7
80	D250	3"	210	33,3	238	407	350	G1/4"	25	100	41	45°	-	17,8

* Dimensions in accordance with DIN 3202 T4 M8
Dimensions in mm

Angle Seat Valve 7010

pressure balanced version

Build up, dimensions and weight

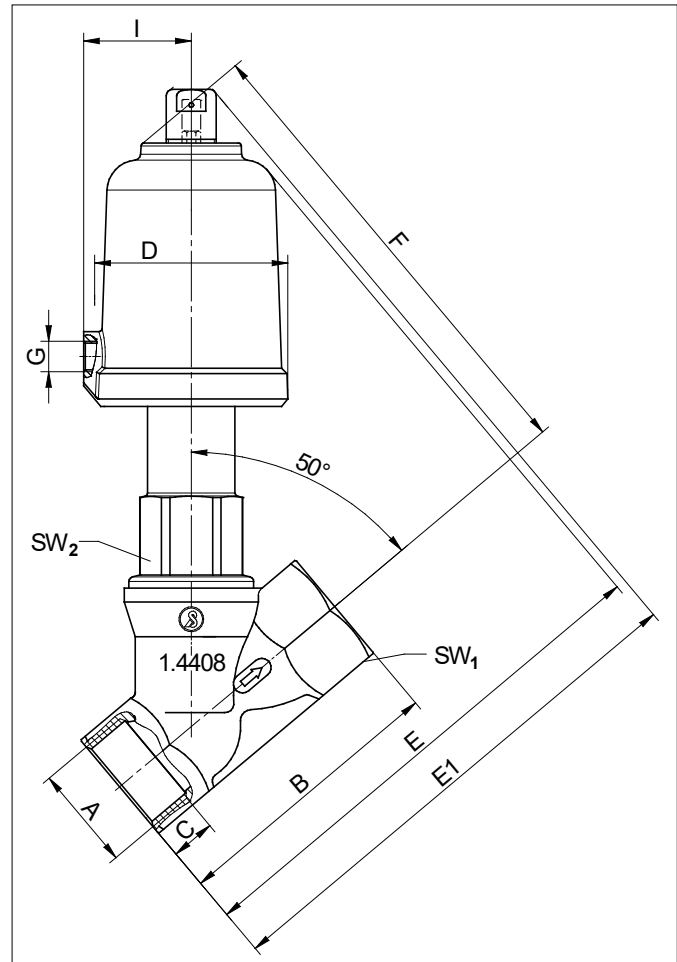
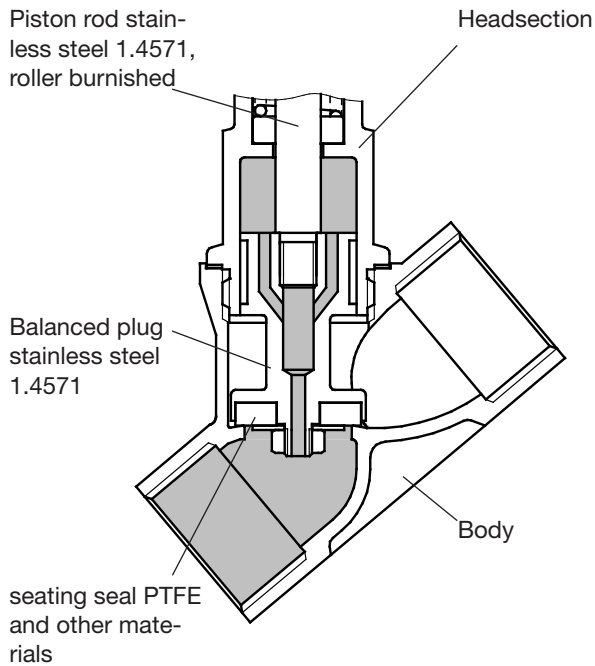

DN	Actuator	A G/NPT	B* stainless steel	C	D	E stainless steel	F	G	H (stroke)	I	SW1 stainless steel	SW 2 Stand.	Kvs-value stainless steel	Weight (kg)
32	50	1 1/4"	110	21,4	62	175	165	G1/8"	16	34,5	48	41	21	2
40	50	1 1/2"	120	21,4	62	185	175	G1/8"	16	34,5	55	46	30	2,3
40	80	1 1/2"	120	21,4	96	220	210	G1/4"	21	55	55	46	35	4,1
50	50	2"	150	25,7	62	200	180	G1/8"	16	34,5	68	52	40	3,3
50	80	2"	150	25,7	96	240	220	G1/4"	22	55	68	52	55	5
50	125	2"	150	25,7	146	265	245	G1/4"	22	80	68	52	55	5,6
65	50	2 1/2"	180	30,2	96	225	200	G1/8"	16	55	85	36	80	5,1
65	80	2 1/2"	180	30,2	96	265	240	G1/4"	29	55	85	36	80	6,8
65	125	2 1/2"	180	30,2	146	290	265	G1/4"	29	80	85	36	80	7,8
80	80	3"	214	33,3	96	325	270	G1/4"	30	55	100	46	112	10,4
80	125	3"	214	33,3	146	355	300	G1/4"	30	80	100	46	112	11,8

* Dimensions in accordance with DIN 3202 T4 M8
Dimensions in mm

Angle Seat Valve 7010

Version HT220

Dimensions and weight

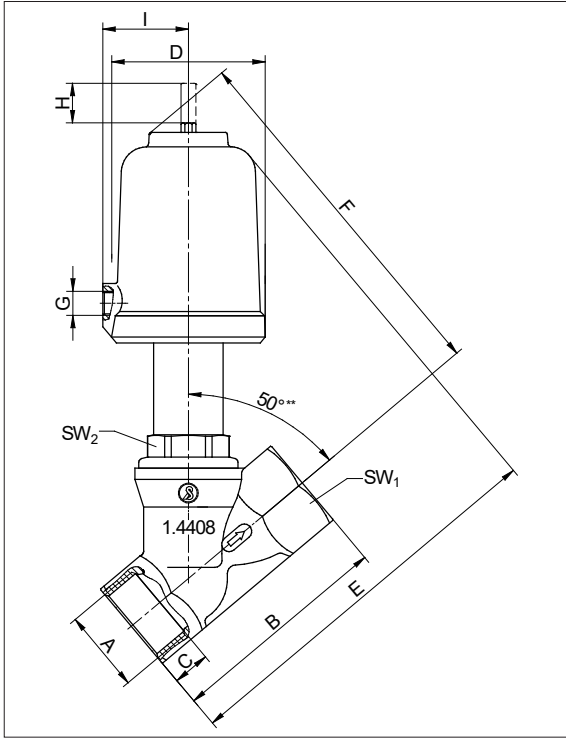

Normally closed

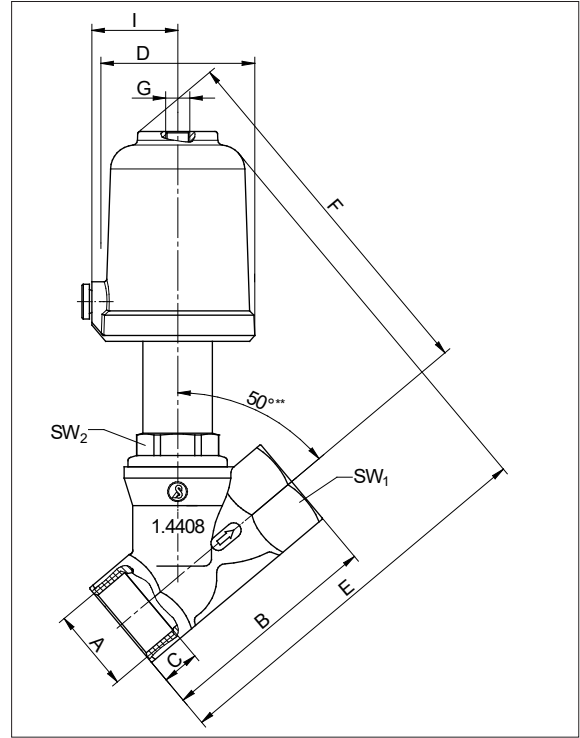

Normally open

DN	Actuator diameter	A G/NPT	B *	C	D	E	F	G	H	I	SW1	SW2	Kvs-values	Weight (approx. kg)
10	50	3/8"	60	12	62	142,3	139,4	G1/8	6,35	34,5	23	30	1,6	1,1
15	50	1/2"	65	15	62	145	139	G1/8	7	34,5	25	30	3,5	1,2
20	50	3/4"	75	16,3	62	152	144	G1/8	12	34,5	31	30	8	1,3
	80	3/4"	75	16,3	96	186	181	G1/4	12	55	31	30	8	1,9
25	80	1"	90	19,1	96	193	185	G1/4	16	55	39	30	16	3,1
	125	1"	90	19,1	146	223	215	G1/4	16	80	39	30	16	5,3
32	80	1 1/4"	110	21,4	96	211	201	G1/4	20	55	48	30	24	3,4
	125	1 1/4"	110	21,4	146	241	231	G1/4	20	80	48	30	24	5,6
40	80	1 1/2"	120	21,4	96	216,2	206,1	G1/4	22	55	55	30	35	3,7
	125	1 1/2"	120	21,4	146	244,6	234,6	G1/4	22	80	55	30	35	5,9
50	125	2"	150	25,7	146	260,4	241,5	G1/4	25,5	80	68	32	55	6,5
65	125	2 1/2"	180	30,2	146	288,9	262,4	G1/4	29	80	85	36	80	7,1

* Dimensions in accordance with DIN 3202 T4 M8

Dimensions in mm

Angle Seat Valve 7010

Temperature versions

Valves with piston actuator

Version	Description	Fluid temperature	Ambient temperature
1	Standard - Bronze	-30°C up to +170°C	-15°C up to +60°C
2	Standard - Stainless steel	-30°C up to +170°C	-15°C up to +60°C
3	HT220 - version, only with PEEK seating seal	+160°C up to +220°C	-15°C up to +100°C
4	High temperature version in stainless steel	-30°C up to +200°C	-15°C up to +100°C
5	High temperature version for bronze or brass body		
6	Exterior lip seal made of Viton for bronze or brass body		
7	Low temperature version acc. to drawing R0194 for stainless steel body	-50°C up to +135°C	-15°C up to +60°C
8	Low temperature version acc. to drawing R0188 for stainless steel body		
9	Low temperature version acc. to drawing R0188 for bronze or brass body		
10	Low temperature version for stainless steel body	-40°C up to +170°C	-15°C up to +60°C
11	Low temperature version for bronze or brass body		
12	Bonnet for actuator made of polymer for stainless steel body	-30°C up to +135°C	-15°C up to +60°C
13	Bonnet for actuator made of polymer for bronze or brass body		
14	Low temperature version with bonnet for actuator made of polymer and stainless steel body	-40°C up to +135°C	-15°C up to +60°C
15	Low temperature version with bonnet for actuator made of polymer for bronze or brass body		
16	Long head section (without bellows)	-70°C up to +200°C	-15°C up to +60°C
17	Long head section with bellows	-100°C up to +200°C	-15°C up to +60°C
18	Standard, bronze with seals from NBR	-30°C up to +170°C	-30°C up to +60°C
19	Standard, stainless steel with seals from NBR		
20	Low temperature version, seating seal made of NBR and bronze or brass body	-40°C up to +170°C	-30°C up to +60°C
21	Low temperature version, seating seal made of NBR and stainless steel body		

Valves with diaphragm actuator

Version	Description	Fluid temperature	Ambient temperature
22	Diaphragm actuator D250	-30°C up to +200°C	-30°C up to +60°C
23	Low temperature version for diaphragm actuator D250	-40°C up to +200°C	-30°C up to +60°C
24	Low temperature version for diaphragm actuator D250 with head section extension	-50°C up to +200°C	-30°C up to +60°C

Angle Seat Valve 7010

Body designs

Body made of stainless steel 1.4408 with female thread G/NPT

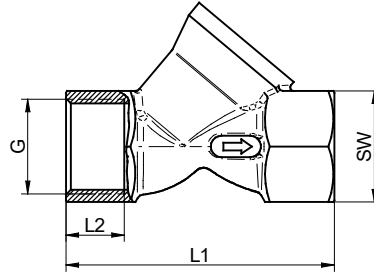

DN	Withworth pipe thread „G“ acc. ISO 228-1 Code: „0“				NPT-thread acc. ANSI B 1.20.1 Code: „5“			
	L1	L2	G	SW	L1	L2	G	SW
08	60	12	G 1/4"	20	60	10,7	NPT 1/4"	20
10	60	12	G 3/8"	23	60	11	NPT 3/8"	23
15	65	15	G 1/2"	25	65	14,5	NPT 1/2"	25
20	75	16,3	G 3/4"	31	75	15	NPT 3/4"	31
25	90	19,1	G 1"	39	90	18	NPT 1"	39
32	110	21,4	G 1 1/4"	48	110	18,5	NPT 1 1/4"	48
40	120	21,4	G 1 1/2"	55	120	18,5	NPT 1 1/2"	55
50	150	25,7	G 2"	68	150	19	NPT 2"	68
65	180	30,2	G 2 1/2"	85	180	25,5	NPT 2 1/2"	85
80	214	33,5	G 3"	100	214	27,4	NPT 3"	100

Dimensions in mm

Body made of stainless steel 1.4408 mit conical pipe thread Rc

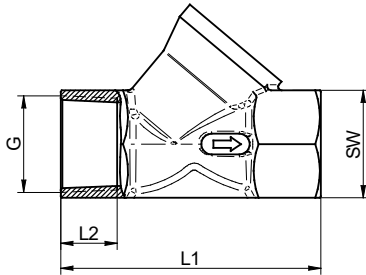

DN	Conical pipe thread „Rc“ acc. EN 10226-2 Code: „T“			
	L1	L2	G	SW
08	61	12	Rc 1/4"	20
10	60	11,4	Rc 3/8"	23
15	65	15	Rc 1/2"	25
20	75	16,3	Rc 3/4"	31
25	90	19,1	Rc 1"	39
32	110	21,4	Rc 1 1/4"	48
40	120	21,4	Rc 1 1/2"	55
50	150	25,7	Rc 2"	68

Dimensions in mm

Body made of stainless steel 1.4408 without thread

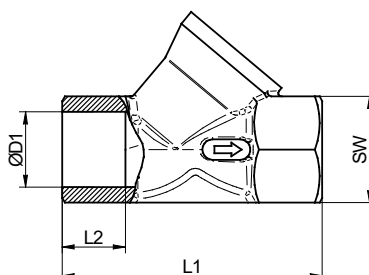

DN	Code: „6“			
	L1	L2	D1	SW
08	61	16,5	10	20
10	61	16,5	13	23
15	66	16,5	17	25
20	76	18,5	22	31
25	91	16,5	27,5	39
32	111	24	36,5	48
40	121	24	42,5	55
50	151	29	54	68
65	182	38	66	85
80	214	38,5	80	100

Dimensions in mm

Angle Seat Valve 7010

Body designs

Body made of stainless steel 1.4408 with welding ends DIN/ISO

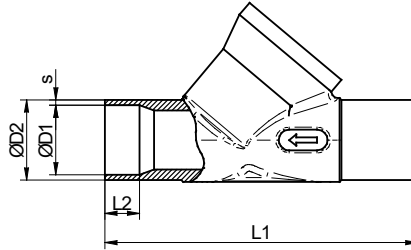

DN	Welding ends acc DIN 11850 series 2 Code: "D"				Welding ends acc ISO 1127 - B Code: "H"			
	L1	L2	D2	s	L1	L2	D2	s
08	-	-	-	-	-	-	-	-
10	-	-	-	-	-	-	-	-
15	80	20	19	1,5	80	20	21,3	2
20	90	22	23	1,5	90	22	26,9	2,3
25	100	21	29	1,5	100	21	33,7	2,6
32	110	20	35	1,5	110	20	42,4	2,6
40	120	22	41	1,5	120	22	48,3	2,6
50	150	28	53	1,5	150	28	60,3	2,9
65	180	28	70	2	180	28	76,1	2,9
80	-	-	-	-	220	17,5	88,9	3,2

Dimensions in mm

Body made of stainless steel 1.4408 with socked-welds

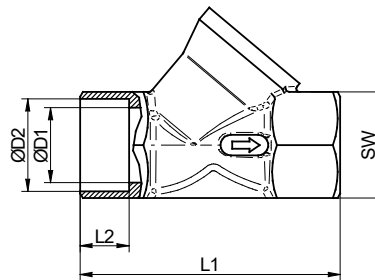

DN	socked-welds acc. R0103 Code: "2"					socked-welds acc. R 0094 Code: "E"				
	L1	L2	D1	D2	SW	L1	L2	D1	D2	SW
08	-	-	-	-	-	-	-	-	-	-
10	-	-	-	-	-	-	-	-	-	-
15	66	12,7	17	21,7	25	66	5	17	20,5	25
20	76	14,3	22	27,1	31	76	5	22	25,5	31
25	91	15,9	27,5	33,8	39	91	5	27,5	30,5	39
32	111	17,5	36,5	42,6	48	111	5	36,5	38,5	48
40	121	19,1	42,5	48,6	55	121	5	42,5	45	55
50	151	22,2	54	61,1	68	151	5	54	57,5	68
65	182	25	66	73,8	85	182	5	66	76,6	85
80	214	25,4	80	89,7	100	214	5	80	89	100

Dimensions in mm

Angle Seat Valve 7010

Body designs

Body made of stainless steel 1.4408 with welding ends ASME BPE

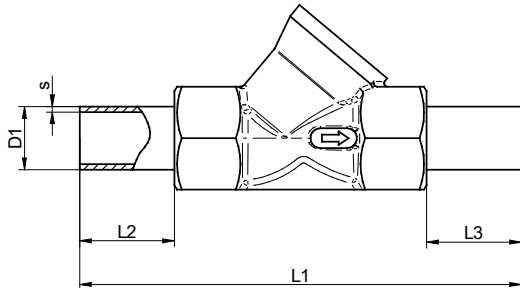

DN	Welding ends acc. R0129 Code: "3"				
	L1	L2	L3	D1	s
08	99,1	19,05	19,05	6,35	1,65
10	-	-	-	-	-
15	116,8	25,4	25,4	12,7	1,24
20	133,2	28,6	28,6	19,05	1,65
25	167,2	38,1	38,1	25,4	1,65
32	-	-	-	-	-
40	197,2	25,4	50,8	38,1	1,65
50	216	32,5	32,5	50,8	1,65
65	-	-	-	-	-

Dimensions in mm

Body made of stainless steel 1.4408 with Clamp-connections

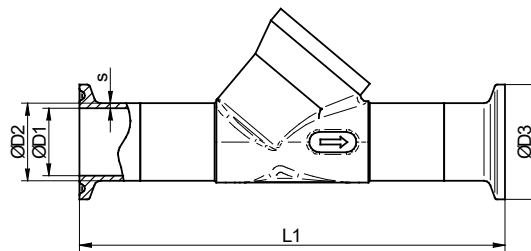

DN	Clamp connection acc. DIN Code: "N"					Clamp connection acc. ISO Code: "K"				
	L1	D1	D2	s	D3	L1	D1	D2	s	D3
08	-	-	-	-	-	-	-	-	-	-
10	-	-	-	-	-	-	-	-	-	-
15	116	16	19	1,5	34	116	18,1	21,3	1,6	34
20	126	20	23	1,5	34	133	23,7	26,9	1,6	50,5
25	143	26	29	1,5	50,5	143	29,7	33,7	2	50,5
32	153	32	35	1,5	50,5	153	38,4	42,4	2	50,5
40	163	38	41	1,5	50,5	163	44,3	48,3	2	64
50	193	50	53	1,5	64	206	56,3	60,3	2	77,5
65	236	66	70	2	91	236	72,1	76,1	2	91
80	-	-	-	-	-	276	84,3	88,9	2,3	106

Dimensions in mm

DN	Clamp-connection acc. Inch Code: "Z"		
	L1	D1	D3
08	-	-	-
10	-	-	-
15	120	9,5	25
20	130	15,7	25
25	143	21,9	50,5
32	167	28,5	50,5
40	163	35,1	50,5
50	193	47,8	64
65	233	60,5	77,5

Dimensions in mm

Angle Seat Valve 7010

Body designs

Body made of stainless steel 1.4408 with welding ends MF

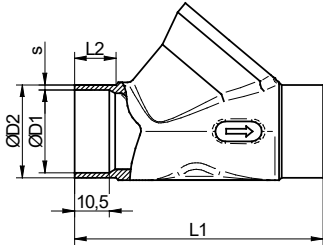

DN	Code: "M"			
	L1	L2	D2	s
08	-	-	-	-
10	-	-	-	-
15	-	-	-	-
20	75	10,5	28	1,5
25	-	-	-	-
32	-	-	-	-
40	-	-	-	-
50	-	-	-	-
65	-	-	-	-

Dimensions in mm

Body made of stainless steel 1.4408 with male thread

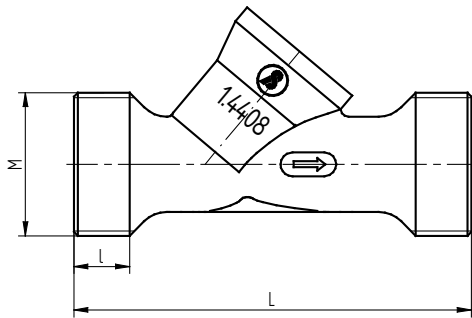

DN	Other special versions Code: „2“		
	M	L	l
08	-	-	-
10	M25x1,5	76	14
15	-	-	-
20	M36x2	100	12
25	-	-	-
32	-	-	-
40	-	-	-
50	-	-	-
65	-	-	-
80	-	-	-

Dimensions in mm