

Aseptic Right Angle Control Valve 6051

1/2" up to 2 1/2"



Pneumatic control valve in right angle design with integrated microprocessor positioner type 8049 or as a shut-off valve for applications in pharmaceutical and food industry.

- Perfect cleanability by optimized flow condition in relation to constant high wall shear stress
- EHEDG certified design for easy cleaning in place
- Body made from non-porous barstock material
- Medium is sealed by the diaphragm
- Solid design of the diaphragm for extreme variations in temperature
- High chemical resistance by a composite diaphragm made of PTFE and reinforced EPDM
- Simple and clever design
- Customer-friendly maintenance
- Parts are FDA conformant, comply with the USP class VI and regulations (EG) 1935/2004 and (EU) 10/2011
- Suitable for vacuum applications



Control valve with positioner type 8049

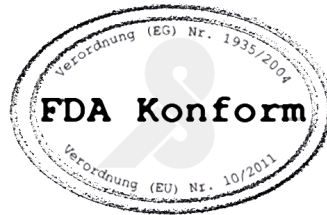
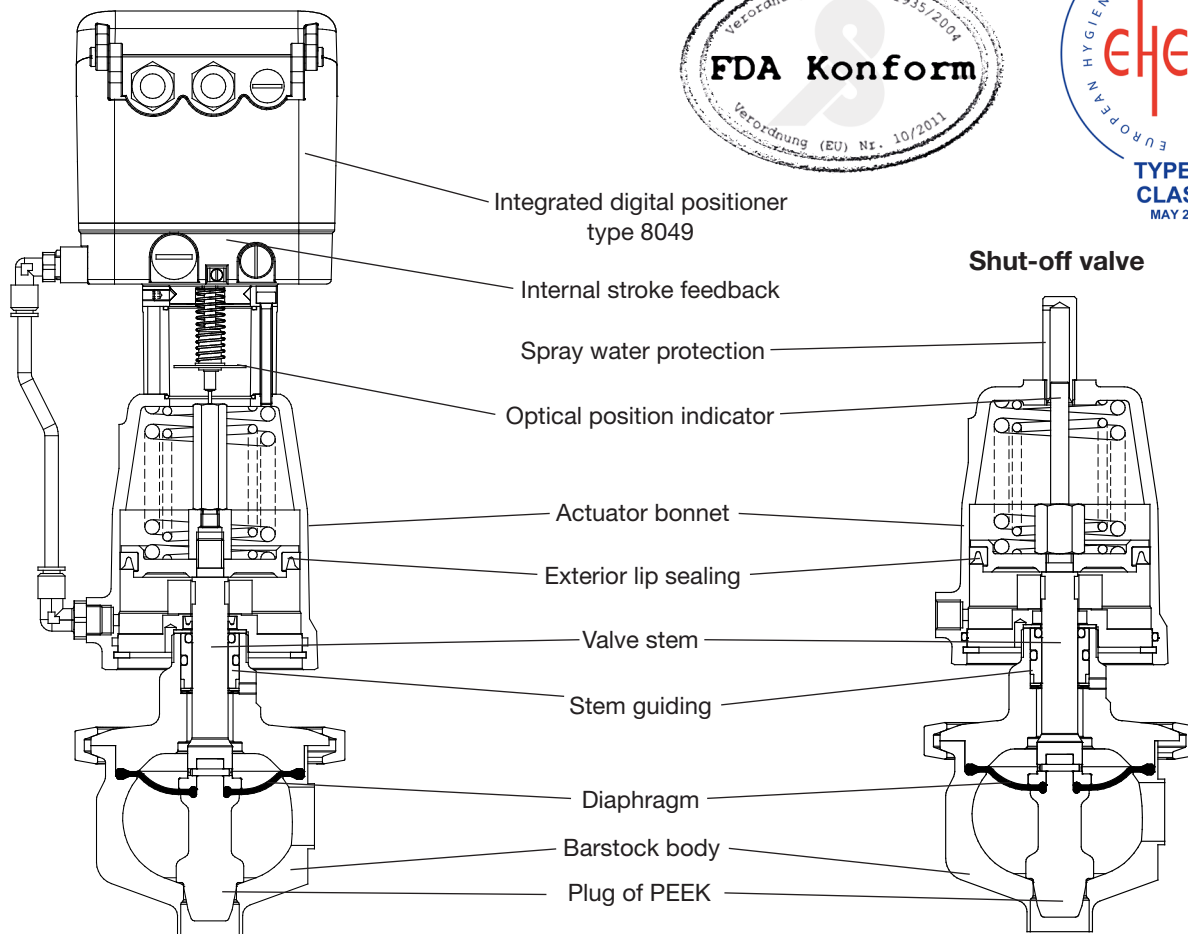

Technical Information Valve

Body material	Stainless steel 316L (1.4435)
Nominal sizes	1/2" up to 2 1/2"
Connections	Welding ends DIN 11850 series 2 Welding ends ASME BPE Welding ends ISO 1127 Tri-clamp acc. Inch (DIN 32676-C)
Nominal pressure	235 psi
Diaphragm	Reinforced EPDM diaphragm with PTFE-foil (fluidside)
Fluid temperature	-4°F up to +284°F
ambient temperature	digital positioner +14°F up to +167°F analog positioner +5°F up to +140°F
Rangeability	50 : 1
Vacuum	maximum 0.0295 mercury (Hg)
Hysteresis	< 0,5 %
Surface finish inside	Ra < 23,6 µin electropolished, Ra < 15,7 µin (optional for body)
Surface finish outside	Ra < 47,3 µin

Materials

Valve body	Stainless steel 316L (1.4435)
Actuator	Stainless steel 316L (1.4408) (optional: polished)
Diaphragm actuator	Stainless steel ASTM A313 304
Actuator springs	Stainless steel ASTM A313 301
Valve stem	Stainless steel 316 Ti
Control plug	PEEK
Clamp-connection	Stainless steel 316L (1.4435)
Body positioner	Aluminium, filled PA, optional: stainless steel 303
Body position indicator	PA Polyamid (clear)

Positioner

For technical information of our positioners, type 8049 or 8047, refer to the corresponding data sheets.

CVS-Values with EHEDG Certification (body ASME-BPE)

characteristic	linear					equal percentage				
	1/2"	3/4"	1"	1 1/2"	2"	1/2"	3/4"	1"	1 1/2"	2"
Size	1/2"	3/4"	1"	1 1/2"	2"	1/2"	3/4"	1"	1 1/2"	2"
100%	3,6(2,73)	4	9,4	22,2	40,6	2,67 (2,2)	2,78	6,6	12,64	-
reduced (63 %)	2,2	2,2	5,45	16,2	-	1,62	1,62	3,25	7,77	-
reduced (40 %)	1,16	1,16	3,8	10,2	-	1,04	1,04	2,78	-	-
reduced (25 %)	1	1	2,2	-	-	-	-	1,62	-	-
reduced (16 %)	0,64	0,64	1,16	-	-	-	-	1,04	-	-
reduced (10 %)	0,41	0,41	1	-	-	-	-	-	-	-
reduced (6,3 %)	0,22	-	0,64	-	-	-	-	-	-	-
reduced (4 %)	-	-	0,41	-	-	-	-	-	-	-
reduced (2,5 %)	0,07	0,07	-	-	-	-	-	-	-	-
stroke (inch)	0,55					0,55				

CVS-Values without EHEDG Certification (body ASME-BPE)

characteristic	linear						equal percentage				
	1/2"	3/4"	1"	1 1/2"	2"	2 1/2"	1/2"	3/4"	1"	1 1/2"	2"
Size	1/2"	3/4"	1"	1 1/2"	2"	2 1/2"	1/2"	3/4"	1"	1 1/2"	2"
100%	4,18 (3)	4,6	11,6	27,7	46,4	69,6	4 (2,9)	4,6	11,48	21,3	37
reduced (63 %)	2,67	2,67	6,5	18,6	-	-	2,9	2,9	7,3	16,8	-
reduced (40 %)	1,45	1,45	4,6	11,6	-	-	1,9	1,9	4,6	-	-
reduced (25 %)	1,16	1,16	2,67	-	-	-	-	-	2,9	-	-
reduced (16 %)	0,73	0,73	1,45	-	-	-	-	-	1,9	-	-
reduced (10 %)	0,46	0,46	1,16	-	-	-	-	-	-	-	-
reduced (6,3 %)	0,29	-	0,73	-	-	-	-	-	-	-	-
reduced (4 %)	-	-	0,46	-	-	-	-	-	-	-	-
reduced (2,5 %)	0,12	0,12	-	-	-	-	-	-	-	-	-
stroke (inch)	0,63					0,94	0,63				

Aseptic Right Angle Control Valve 6051



Admissible differential pressures for control valves with positioner type 8049

Size	Actuator	Springs	P _{Supply} [psi]	P2	Max. Operating pressure P1 [psi] (depending on holding pressure P2 [psi])																											
					0	15	29	31	32	34	35	37	38	40	41	43	44	58	73	87	89	90	92	93	95	96	98	99	105			
1/2"	3"	2	73 to 87	max. P1	145	145	145	145	145	145	145	145	125	105	79	57																
	5"	3	58 to 87	max. P1	145	145	145	145	145	145	145	145	145	145	145	145	145	145	145	145	145	145	145	145	140	115						
3/4"	3"	2	73 to 87	max. P1	145	145	145	145	145	145	145	145	125	105	79	57																
	5"	3	58 to 87	max. P1	145	145	145	145	145	145	145	145	145	145	145	145	145	145	145	145	145	145	145	140	115	0	0	0				
1"	3"	2	73 to 87	max. P1	145	145	135	125	110	93	79	64	50	35	28																	
	5"	3	58 to 87	max. P1	145	145	145	145	145	145	145	145	145	145	145	145	145	145	135	120	105	90	76									
	10"	6	44 to 87	max. P1	145	145	145	145	145	145	145	145	145	145	145	145	145	145	145	145	145	145	145	145	145	145	135	130	115			
1 1/2"	5"	3	58 to 87	max. P1	145	145	145	134	125	120	110	105	95	87	80	73	66	58	56													
	10"	6	44 to 87	max. P1	145	145	145	145	145	145	145	145	145	145	145	145	145	145	145	140	135	125	120	110	105	95	87	80				
2"	5"	3	58 to 87	max. P1	86	82	77	74	73	69	64	60	58	56	54	51	47	43	38	37												
	10"	6	44 to 87	max. P1	110	110	110	110	110	110	110	110	110	110	105	105	99	95	90	87	86	82	77	73	69	64	64	58	0			
2 1/2"	5"	3	58 to 87	max. P1	38	35	34	32	31	29	28	27	25	24	21	19																
	10"	6	44 to 87	max. P1	44	44	44	44	44	44	43	41	40	38	37	35	32	31	29	28	27											

Suitable for vacuum applications

Admissible differential pressures for shut-off valves (spring to close*)

Size	Actuator	Springs	P _{Supply} [psi]	P2	Max. Operating pressure P1 [psi] (depending on holding pressure P2 [psi])																											
					0	15	29	31	32	34	35	37	38	40	41	43	44	58	73	87	89	90	92	93	95	96	98	99	105			
1/2"	3"	2	73 to 87	max. P1	205	205	205	205	205	185	160	145	125	105	76	57																
	5"	3	58 to 87	max. P1	110	110	110	110	110	110	110	110	110	110	110	105	105	99	95	90	87	86	82	77	73	69	64	64	58	0		
3/4"	3"	2	73 to 87	max. P1	205	205	185	160	145	125	105	79	57																			
	5"	3	58 to 87	max. P1	205	205	205	205	205	205	205	205	205	205	205	205	205	205	205	205	205	205	200	175	155	140	115					
1"	3"	2	73 to 87	max. P1	145	145	135	63	110	93	79	64	50	35	28																	
	5"	3	58 to 87	max. P1	205	205	205	205	205	205	205	205	205	205	205	205	205	205	200	190	185	145	115	76								
	10"	6	44 to 87	max. P1	205	205	205	205	205	205	205	205	205	205	205	205	205	205	205	205	205	205	205	205	205	200	190	175	145	115		
1 1/2"	5"	3	58 to 87	max. P1	160	160	155	145	140	135	134	130	125	120	115	110	105	95	87	80	73	66	58	56								
	10"	6	44 to 87	max. P1	160	160	160	160	160	160	160	160	160	160	160	160	160	160	160	160	160	160	155	145	145	140	135	125	87	80		
2"	5"	3	58 to 87	max. P1	86	83	82	74	73	69	64	60	56	54	51	47	43	38	37													
	10"	6	44 to 87	max. P1	135	135	135	130	125	120	120	115	110	105	105	99	95	90	87	86	83	77	73	69	64	63	64	56				
2 1/2"	5"	3	58 to 87	max. P1	38	35	34	31	29	28	25	24	21	19																		
	10"	6	44 to 87	max. P1	45	45	45	45	44	43	40	37	37	35	32	31	29	28	27													
	250	8	39 to 87	max. P1	45	45	45	45	45	45	45	45	45	45	45	45	45	45	45	45	45	45	45	45	44	43	41	40				

Suitable for vacuum applications
Intermediate values can be interpolated linearly

Admissible differential pressures Control valves with electric actuator Type 2030

DN	Actuator	Driving force	P2	Max. Operating pressure P1 [psi] (depending on holding pressure P2 [psi])																			
				0	8	15	22	29	37	44	51	58	66	73	80	87	95	105	110	120	125	135	140
1/2"	Type 2030	2 kN	max. P1	145	145	145	145	145	145	145	145	145	61										
		5 kN	max. P1	145	145	145	145	145	145	145	145	145	145	145	145	145	145	145	145	145	145	145	145
3/4"	Type 2030	2 kN	max. P1	145	145	145	145	145	145	145	145	145	61										
		5 kN	max. P1	145	145	145	145	145	145	145	145	145	145	145	145	145	145	145	145	145	145	145	145
1"	Type 2030	2 kN	max. P1	145	145	145	125	87	51														
		5 kN	max. P1	145	145	145	145	145	145	145	145	145	145	145	145	145	145	145	145	145	145	145	145
1 1/2"	Type 2030	5 kN	max. P1	145	145	145	145	145	145	145	145	145	145	145	145	145	145	145	145	145	145	145	145
2"	Type 2030	5 kN	max. P1	135	135	135	135	135	135	135	135	135	135	125	115	105	90						
2 1/2"	Type 2030	5 kN	max. P1	87	87	87	87	87	87	87	87	87	87	87	87	87	80	73					

Example:
P1= 116 psi, P2= 67

Actuator	Springs	P _{Supply} [psi]	P2	0	2	3	6	9	12	15	18	21	24	25	29	31	58	61	64	67	70	73	74	93	95	96	98	105
3"	2	73 to 87	max. P1	145	145	135	125	110	93	79	64	50	35	28														
5"	3	58 to 87	max. P1	145	145	145	145	145	145	145	145	145	145	145	145	145	145	135	120	105	90	76						
10"	6	44 to 87	max. P1	145	145	145	145	145	145	145	145	145	145	145	145	145	145	145	145	145	145	145	145	145	145	135	130	115

Result: Actuator 5" is too small and can only be used up to P1=104 psi
Actuator 10" is sufficient

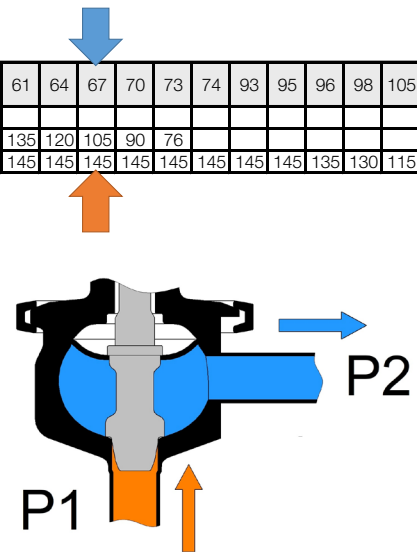

Admissible differential pressures for shut-off valves (spring to open*)

Kvs	Actuator	Pst	Max. operating pressure P1 [psi] (depending on holding pressure P2 [psi])															
			0	7	14	21	29	36	43	50	58	65	72	79	87	94	100	
0,4 - 1,0	D80	22																
		29	230	15														
		37	230	230	155													
		44		230	230	230	10											
		51				230	230	150										
		58					230	230	230	4								
		66							230	230	145							
		73								230	230	230						
		80										230	230	140				
		87											230	230	230			
		105														230	230	
		120																
		135																
		145																
		0,4 - 1,0	D125	15	230	230	155											
22					230	230	230	230	82									
29								230	230	230	230	230						
37												230	230	230	230	215		
44																230	230	
51																		
58																		
0,4 - 1,0	D250	21																
		24	50															
		27	230	230	230	76												
		29		230	230	230	230	230	100									
		32						230	230	230	230	125						
		35									230	230	230	150				
		38											230	230	230	230	230	
		41															230	
1,6 - 4,0	D80	22																
		29																
		37	135	37														
		44	230	185	92													
		51	230	230	230	145	49											
		58		230	230	230	200	105	5									
		66				230	230	230	155	62								
		73						230	230	210	115	18						
		80							230	230	230	165	73					
		87									230	230	220	125	30			
		105												230	230	230	140	
		120															230	
		135																
		145																
		1,6 - 4,0	D125	15	135	37												
22	230			230	230	220	125	29										
29						230	230	230	230	215	115	18						
37										230	230	230	230	200	105	10		
44													230	230	230	230	230	
51																	230	
58																		
1,6 - 4,0	D250	21																
		24																
		27	210	110	13													
		29	230	230	230	230	130	36										
		32			230	230	230	230	230	150	59							
		35						230	230	230	230	230	180	82				
		38									230	230	230	230	230	200	105	
		41													230	230	230	

The specified control pressures for NO valves may be exceeded by a maximum of 3 psi

Admissible differential pressures for shut-off valves (spring to open*)

Kvs	Actuator	Pst	Max. operating pressure P1 [psi] (depending on holding pressure P2 [psi])														
			0	7	14	21	29	36	43	50	58	65	72	79	87	94	100
6,3 - 10	D80	37															
		44	17														
		51	66	40	13												
		58	115	89	62	36	8										
		66	155	135	110	85	59	31	5								
		73	200	185	155	130	105	81	55	27	1						
		80	200	200	200	180	150	130	100	76	50	23					
		87			200	200	200	170	150	125	100	73	46	20			
		105						200	200	200	195	165	145	115	91	65	37
	120										200	200	200	185	155	135	
	135													200	200	200	
	145																
	15																
	22	91	65	37	11												
	29	200	185	155	130	105	81	55	27	1							
	37	200	200	200	200	200	200	170	150	120	98	71	44	17			
	44						200	200	200	200	200	195	165	140	110	88	
	51											200	200	200	200	200	
	58															200	
	66																
	27																
	29	94	66	40	14												
	32	195	165	140	115	89	62	36	8								
	35	200	200	200	200	185	155	135	110	85	58	31	4				
	38			200	200	200	200	200	200	180	155	130	105	79	53	27	
	41							200	200	200	200	200	200	180	150	125	
	44											200	200	200	200	200	
47															200		
50																	
53																	
15 - 25	D80	37															
		44															
		51															
		58	23	13	2												
		66	49	39	29	18	8										
		73	73	63	53	43	33	23	13	2							
		80	98	88	79	69	59	49	39	29	18	8					
		87	120	110	100	94	84	73	63	53	43	33	23	13	2		
		105	155	155	150	145	130	120	110	100	94	84	73	63	53	43	33
	120				155	155	155	155	150	145	130	120	110	100	94	84	
	135									155	155	155	155	150	145	130	
	145														155	155	
	15																
	22	11	1														
	29	73	63	53	43	33	23	13	2								
	37	135	125	115	105	97	87	76	66	56	46	36	26	15	5		
	44	155	155	155	155	155	145	135	125	115	105	100	89	79	69	59	
	51				155	155	155	155	155	155	155	155	150	140	130	120	
	58											155	155	155	155	155	
	66																
	27																
	29	11	1														
	32	63	55	44	34	24	14	4									
	35	115	105	97	87	76	66	56	46	36	26	15	5				
	38	155	155	145	135	125	115	105	98	88	78	68	58	47	37	27	
	41	155	155	155	155	155	155	155	145	140	130	120	110	100	89	79	
	44					155	155	155	155	155	155	155	155	150	140	130	
47										155	155	155	155	155	155		
50															155		
53															155		

The specified control pressures for NO valves may be exceeded by a maximum of 3 psi

Admissible differential pressures for shut-off valves (spring to open*)

Kvs	Actuator	Pst	Max. operating pressure P1 [psi] (depending on holding pressure P2 [psi])															
			0	7	14	21	29	36	43	50	58	65	72	79	87	94	100	
32 - 40	D80	58																
		66	7	4	1													
		73	23	20	15	13	10	7	2									
		80	37	34	31	29	24	21	18	15	11	8	5	2				
		87	53	50	46	43	40	37	33	30	27	24	20	17	14	11	8	
		105	84	81	78	73	71	68	65	60	58	55	52	47	44	42	39	
		120	110	110	105	100	100	98	95	91	88	85	82	78	75	72	69	
		135	130	130	130	130	130	125	125	120	115	115	110	105	105	100	100	
	145							130	130	130	130	130	130	130	130	130		
	15																	
	22																	
	29	23	20	15	13	10	7	2										
	37	60	58	55	52	47	44	42	39	34	31	29	26	21	18	15		
	44	100	95	92	89	87	82	79	76	73	69	66	63	60	56	53		
	51	130	130	130	125	120	120	115	110	110	105	105	100	98	95	92		
	58		130	130	130	130	130	130	130	130	130	130	130	130	130	130		
	66														130	130	130	
	29																	
	32	17	14	10	7	4	1											
	35	49	44	42	39	36	33	29	26	23	20	15	13	10	7	2		
	38	81	76	73	71	68	63	60	58	55	50	47	44	42	37	34		
	41	110	105	105	100	98	95	92	89	85	82	79	76	72	69	66		
	44	130	130	130	130	130	130	125	120	120	115	110	110	105	100	98		
	47	130	130	130	130	130	130	130	130	130	130	130	130	130	130	130		
	50												130	130	130	130	130	
	53																	
	60	D125	15															
			22															
29			5	5	4	4	2	2	1	1	1							
37			34	34	33	33	31	31	30	30	29	29	29	27	27	26	26	
44			63	63	62	62	60	60	59	59	58	58	56	56	56	55	55	
51			87	87	87	87	87	87	87	87	87	87	87	85	85	84	84	84
58					87	87	87	87	87	87	87	87	87	87	87	87	87	87
66																		
29																		
32		1	1															
35		26	24	24	23	23	21	21	21	20	20	18	18	17	17	15	15	
38		50	49	49	47	47	46	46	44	44	43	43	42	42	40	40	40	
41		73	73	72	72	71	71	69	69	68	68	66	66	65	65	63	63	
44		87	87	87	87	87	87	87	87	87	87	87	87	87	87	87	87	
47		87	87	87	87	87	87	87	87	87	87	87	87	87	87	87	87	
50																		
53																		

The specified control pressures for NO valves may be exceeded by a maximum of 3 psi

Aseptic Right Angle Control Valve 6051



Ordering number system

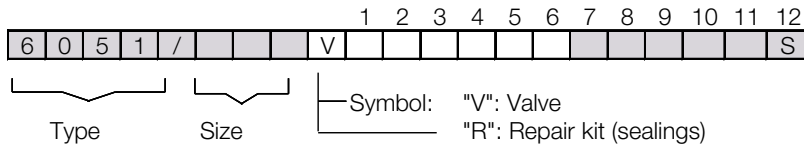

1 - 6 : Please note all 6 sections.
7 - 12: Quote only if required.

1. Design		2. Connections		3. Body material		4. Control plug-/diaphragm-material		5. Positioner		6. Actuator									
A	Aseptic control valve with EHEDG-Certification	D	Welding ends acc. DIN 11850, series 2	7	stainless steel 316L Ra <23,6 µin	E	Control plug of PEEK Ra <23,6 µin diaphragm of EPDM with PTFE-foil (fluid-side) Ra <23,6 µin	-	without (stut-off valve)	8	piston Ø 3" with stainless steel bonnet (NPT)								
												E	Welding ends acc. ASME BPE	9	stainless steel 316L surface roughness inside Ra <15,7 µin electropolished	C	digital positioner type 8049, 4-wire	9	piston Ø 5" with stainless steel bonnet (NPT)
												F	Welding ends acc. ISO 1127	W	digital positioner type 8049, 2-wire	S	piston Ø 3" with plastic bonnet (NPT)		
												Z	Tri-clamp acc. Inch (DIN 32676-C)	K	digital positioner type 8049 ExPro-FM with base plate in stainless steel; Ta = +14°F to +167°F; IS Class I Division 1, Groups A, B, C, D; T4 Entity; Class I Zone 0 AEx ia IIC T4 Entity, IP65	D	diaphragm A250		
B	Aseptic control valve without EHEDG-Certification	E	Spring opens (for digital positioner or shut-off valve)	1	linear equal percentage	-	full (100%)	S	without	S	in case further specials are required								
												R	4 springs	1	red. 40 %	1	1 limit switch (micro switch)	B	digital position indicator with bluetooth
												W	8 springs	2	red. 25 %	2	2 limit switches (micro switch)	C	digital position indicator
												A	red. 63 %	3	red. 16 %	K	1 limit switch compact	D	digital position indicator
M	see following positions	-	Spring opens (for digital positioner or shut-off valve)	1	linear equal percentage	-	full (100%)	S	without	S	AS-I control head el. Position indicator with cable bushing								
												1	red. 25 %	M	2 inductive limit switches	M	AS-I control head el. Position indicator with cable bushing		
												2	red. 10 %	P	1 inductive limit switch	N	Position indicator with plug connection		
												3	red. 6,3 %						

Aseptic Right Angle Control Valve 6051



with integrated digital positioner type 8049

Dimensions and weights

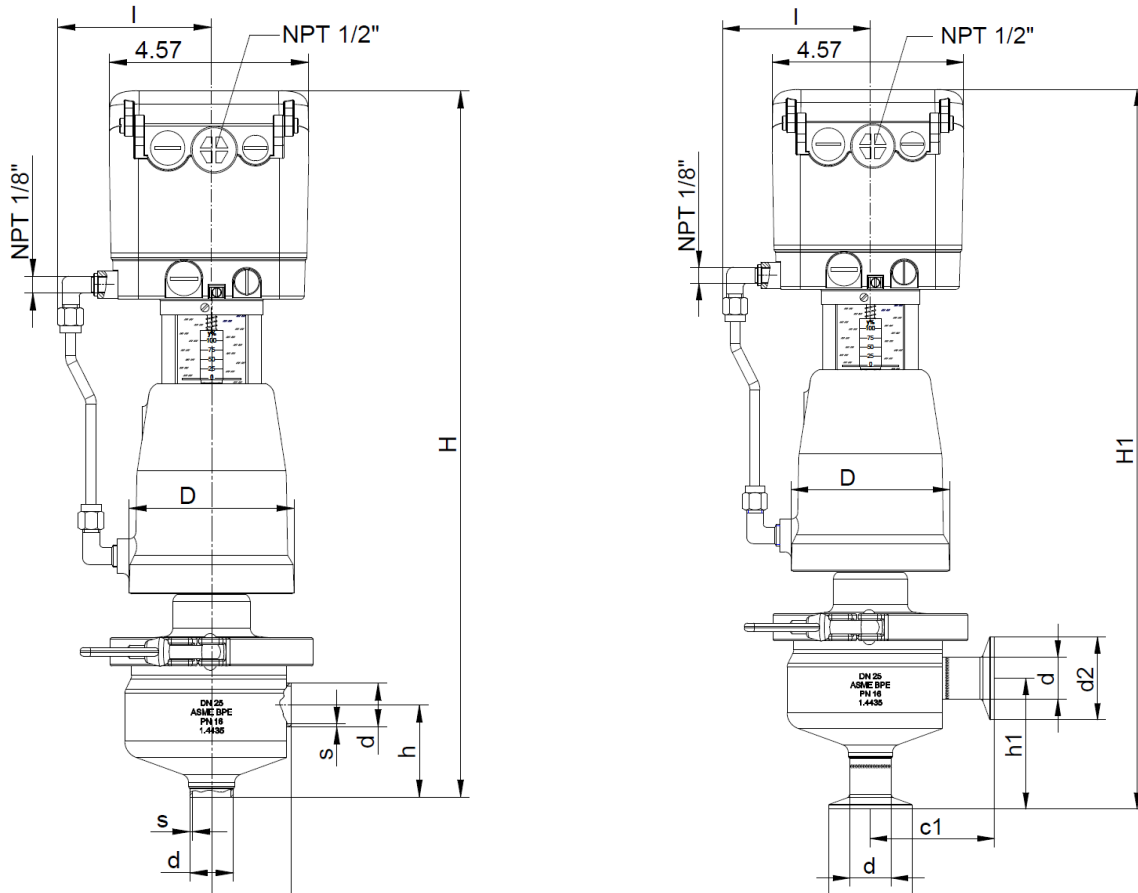

Size	Actuator ø	D	DIN				ISO				ASME BPE				l	H	Weight (~lbs)
			s	d	c	h	s	d	c	h	s	d	c	h			
1/2"	3"	3.78	0.06	0.75	1.83	2.11	0.06	0.84	1.83	2.09	0.06	0.5	1.83	2.42	3,54	16.3	16
1/2"	5"	5.75	0.06	0.75	1.83	2.11	0.06	0.84	1.83	2.09	0.06	0.5	1.83	2.42	4,13	16.7	22
3/4"	3"	3.78	0.06	0.91	1.83	2.11	0.06	1.06	1.83	2.09	0.06	0.75	1.83	2.11	3,54	16.1	16
3/4"	5"	5.75	0.06	0.91	1.83	2.11	0.06	1.06	1.83	2.09	0.06	0.75	1.83	2.11	4,13	16.6	22
1"	3"	3.78	0.06	1.14	1.83	2.11	0.08	1.33	1.83	2.09	0.06	1	1.83	2.11	3,54	16.22	16
1"	5"	5.75	0.06	1.14	1.83	2.11	0.08	1.33	1.83	2.09	0.06	1	1.83	2.11	4,13	17.01	22
1 1/2"	3"	3.78	0.06	41	1.95	1.89	0.08	1.9	1.95	1.85	0.06	1.5	1.95	2.15	3,54	16.42	17
1 1/2"	5"	5.75	0.06	41	1.95	1.89	0.08	1.9	1.95	1.85	0.06	1.5	1.95	2.15	4,13	17.2	23
2"	3"	3.78	0.06	1.61	2.01	2.05	0.08	2.37	2.01	2.05	0.06	2	2.01	2.32	3,54	16.81	18
2"	5"	5.75	0.06	1.61	2.01	2.05	0.08	2.37	2.01	2.05	0.06	2	2.01	2.32	4,13	17.6	24
2 1/2"	5"	5.75	0.1	2.8	2.2	2.6	0.1	3.0	2.2	2.5	0.1	2.5	2.2	2.8	4.1	19.9	27.3

Size	Actuator ø	D	Tri-clamp ASME BPE				l	H1	Weight (~lbs)
			d	d2	c1	h1			
1/2"	3"	3.78	0.5	0.98	2.81	3.37	3.54	17.24	16
1/2"	5"	5.75	0.5	0.98	2.81	3.27	4.13	18.07	22
3/4"	3"	3.78	0.75	0.98	2.81	3.37	3.54	17.24	16
3/4"	5"	5.75	0.75	0.98	2.81	3.27	4.13	18.07	22
1"	3"	3.78	1	1.99	2.96	3.13	3.54	17.24	16
1"	5"	5.75	1	1.99	2.96	3.13	4.13	18.03	22
1 1/2"	3"	3.78	1.5	1.99	3.43	3.9	3.54	18.19	18
1 1/2"	5"	5.75	1.5	1.99	3.43	3.9	4.13	18.98	24
2"	3"	3.78	2	2.52	3.5	3.5	3.54	18.03	18
2"	5"	5.75	2	2.52	3.5	3.5	4.13	18.82	25
2 1/2"	5"	5.75	2.5	3.0	3.5	3.5	4.1	20.7	30

Dimensions in inch

Aseptic Right Angle Control Valve 6051



with integrated digital positioner type 8049

Dimensions and weights

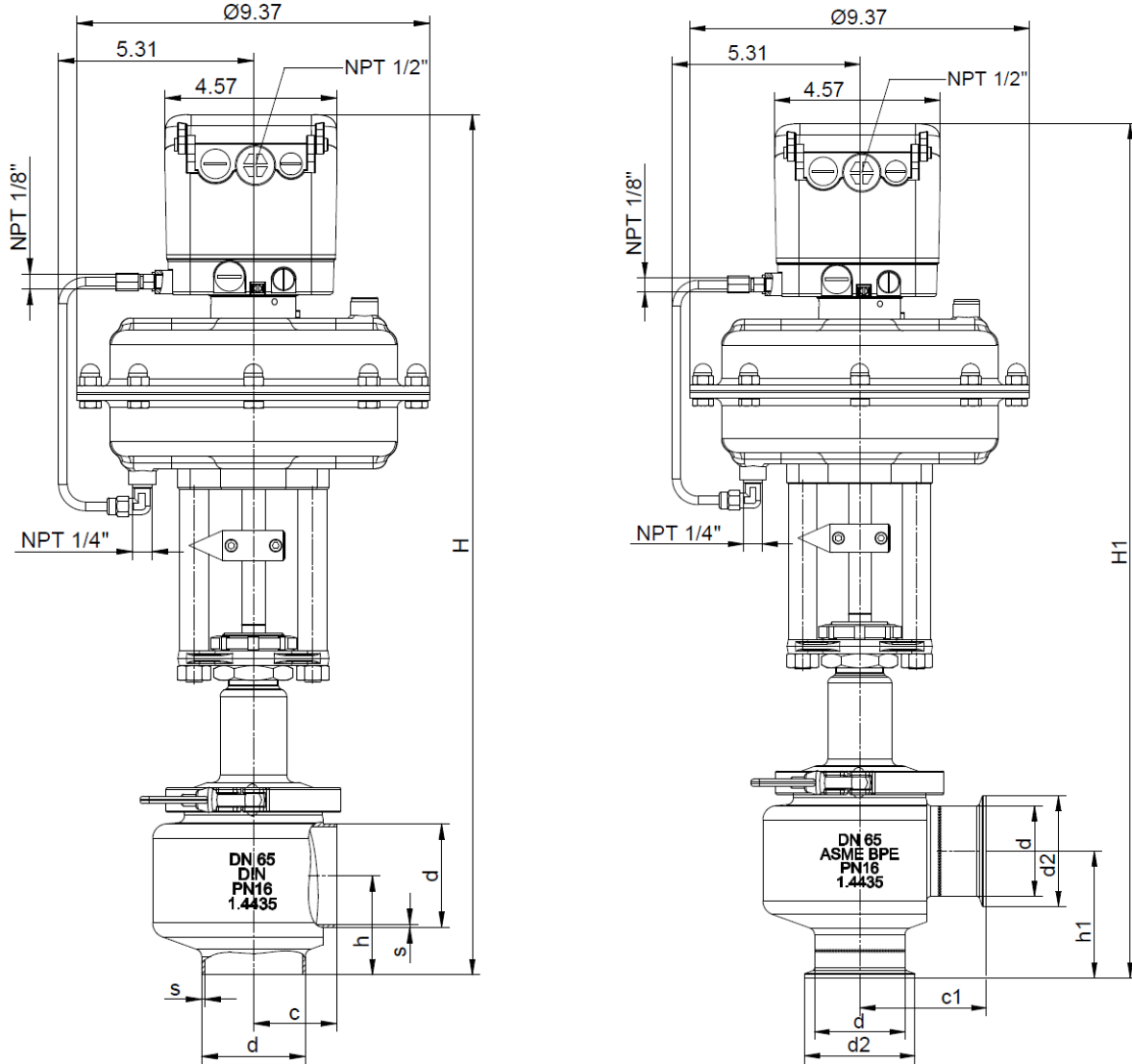

Size	Actuator ø	DIN				ISO				ASME BPE				H	Weight (~lbs)
		s	d	c	h	s	d	c	h	s	d	c	h		
1/2"	10"	0.06	0.75	1.83	2.11	0.06	0,84	1.83	2.09	0.06	0.5	1.83	2.42	20.08	34
3/4"	10"	0.06	0.91	1.83	2.11	0.06	1,06	1.83	2.09	0.06	0.75	1.83	2.11	19.88	34
1"	10"	0.06	1.14	1.83	2.11	0.08	1,33	1.83	2.09	0.06	1	1.83	2.11	20	35
1 1/2"	10"	0.06	41	1.95	1.89	0.08	1,9	1.95	1.85	0.06	1.5	1.95	2.15	20.2	37
2"	10"	0.06	1.61	2.01	2.05	0.08	2,37	2.01	2.05	0.06	2	2.01	2.32	20.59	37
2 1/2"	10"	0.08	2.76	2.2	2.64	0.08	3	2.2	2.52	0.06	2.5	2.2	2.76	22.87	40

Size	Actuator ø	Tri-Clamp ASME BPE				H1	Weight (~lbs)
		d	d2	c1	h1		
1/2"	10"	0.5	0.98	2.81	3.37	20.98	34
3/4"	10"	0.75	0.98	2.81	3.27	20.98	35
1"	10"	1	1.99	2.96	3.13	20.98	35
1 1/2"	10"	1.5	1.99	3.43	3.9	21.93	37
2"	10"	2	2.52	3.5	3.5	21.77	37
2 1/2"	10"	2.5	3.05	3.5	3.5	23.62	42

Dimensions in inch

Aseptic Right Angle Control Valve 6051



shut-off valve with piston actuator

Dimensions and weights

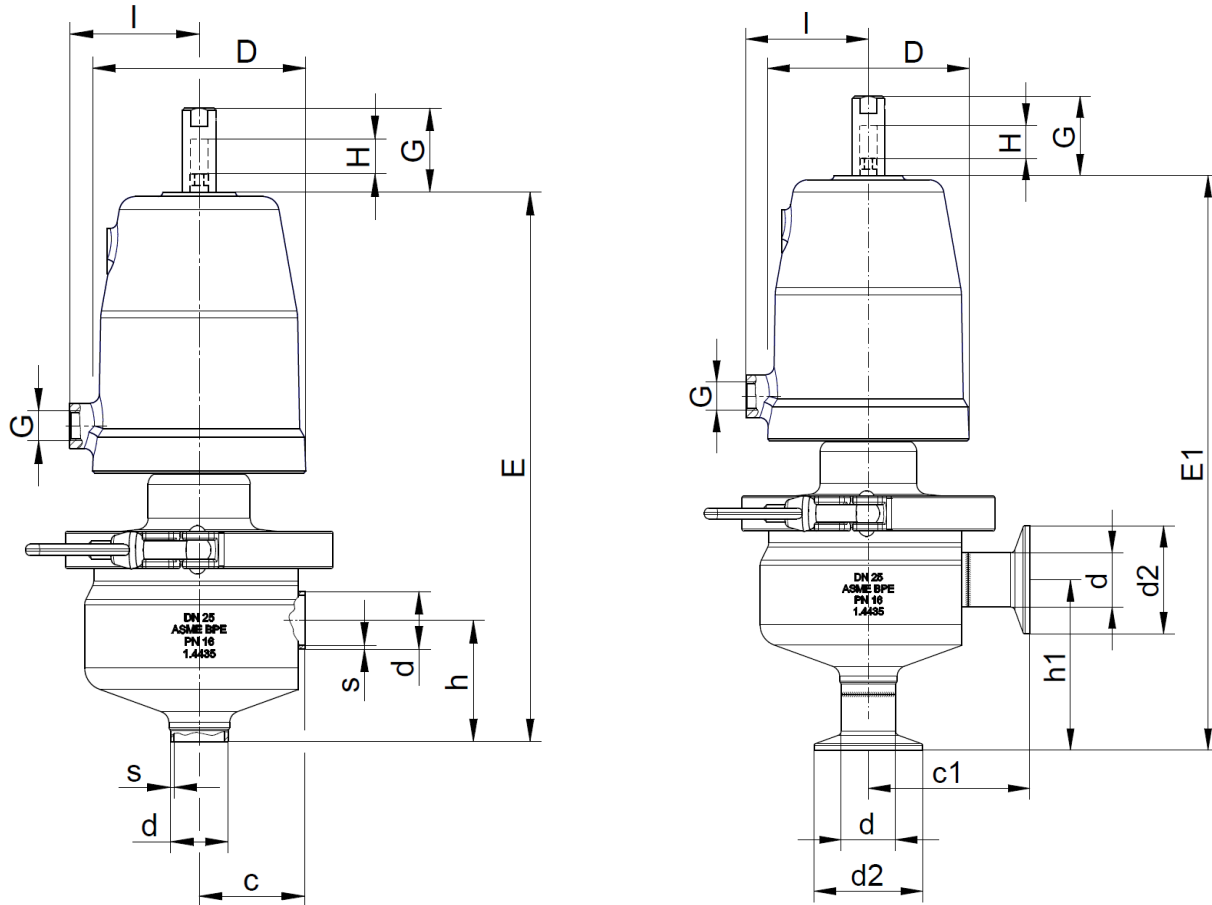

Size	Actuator ø	D	DIN				ISO				ASME BPE				I	H	E	G	Weight (~lbs)
			s	d	c	h	s	d	c	h	s	d	c	h					
1/2"	3"	3.78	0.06	0.75	1.83	2.11	0.06	0.84	1.83	2.09	0.06	0.5	1.83	2.42	2.24	0.63	9.65	1.46	13
3/4"	3"	3.78	0.06	0.91	1.83	2.11	0.06	1.06	1.83	2.09	0.06	0.75	1.83	2.11	2.24	0.63	9.45	1.46	13
1"	3"	3.78	0.06	1.14	1.83	2.11	0.08	1.33	1.83	2.09	0.06	1	1.83	2.11	2.24	0.63	9.57	1.46	13
1"	5"	5.75	0.06	1.14	1.83	2.11	0.08	1.33	1.83	2.09	0.06	1	1.83	2.11	3.15	0.63	10.35	1.46	19
1 1/2"	3"	3.78	0.06	41	1.95	1.89	0.08	1.9	1.95	1.85	0.06	1.5	1.95	2.15	2.24	0.63	9.76	1.46	14
1 1/2"	5"	5.75	0.06	41	1.95	1.89	0.08	1.9	1.95	1.85	0.06	1.5	1.95	2.15	3.15	0.63	10.55	1.46	20
2"	3"	3.78	0.06	1.61	2.01	2.05	0.08	2.37	2.01	2.05	0.06	2	2.01	2.32	2.24	0.63	10.16	1.46	15
2"	5"	5.75	0.06	1.61	2.01	2.05	0.08	2.37	2.01	2.05	0.06	2	2.01	2.32	3.15	0.63	10.94	1.46	21
2 1/2"	5"	5.75	0,08	2,76	2,20	2,64	0,08	3,00	2,20	2,52	0,06	2,50	2,20	2,76	3,15	0,63	13,23	1,46	24,5

Size	Actuator ø	D	Tri-Clamp ASME BPE				I	H	E1	G	Weight (~lbs)
			d	d2	c1	h1					
1/2"	3"	3.78	0.5	0.98	2.81	3.37	2.24	0.63	10.59	1.46	13
3/4"	3"	3.78	0.75	0.98	2.81	3.27	2.24	0.63	10.59	1.46	13
1"	3"	3.78	1	1.99	2.96	3.13	2.24	0.63	10.59	1.46	13
1"	5"	5.75	1	1.99	2.96	3.13	3.15	0.63	11.38	1.46	19
1 1/2"	3"	3.78	1.5	1.99	3.43	3.9	2.24	0.63	11.54	1.46	15
1 1/2"	5"	5.75	1.5	1.99	3.43	3.9	3.15	0.63	12.32	1.46	21
2"	3"	3.78	2	2.52	3.5	3.5	2.24	0.63	11.38	1.46	16
2"	5"	5.75	2	2.52	3.5	3.5	3.15	0.63	12.17	1.46	23
2 1/2"	5"	5.75	2,5	3,051	3,5	3,5	3,15	0,63	14,01	1,46	27,5

Dimensions in inch

Aseptic Right Angle Control Valve 6051



shut-off valve with diaphragm actuator

Dimensions and weights

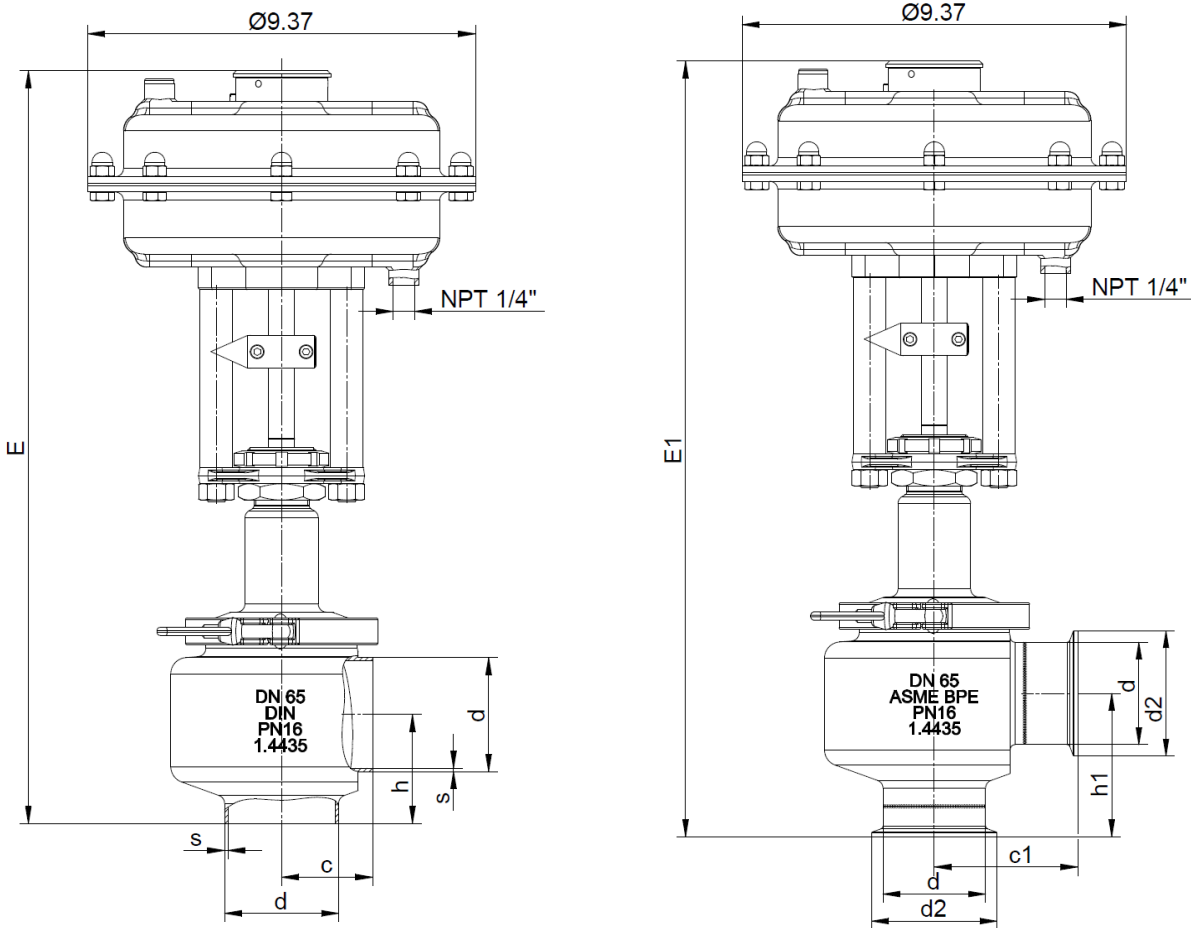

Size	Actuator ø	DIN					ISO				ASME BPE				E	Weight (~lbs)
		s	d	c	h	s	d	c	h	s	d	c	h			
1/2"	10"	0.06	0.75	1.83	2.11	0.06	0.84	1.83	2.09	0.06	0.5	1.83	2.42	15.43	32	
3/4"	10"	0.06	0.91	1.83	2.11	0.06	1.06	1.83	2.09	0.06	0.75	1.83	2.11	15.24	32	
1"	10"	0.06	1.14	1.83	2.11	0.08	1.33	1.83	2.09	0.06	1	1.83	2.11	15.35	32	
1 1/2"	10"	0.06	1.41	1.95	1.89	0.08	1.9	1.95	1.85	0.06	1.5	1.95	2.15	15.55	34	
2"	10"	0.06	1.61	2.01	2.05	0.08	2.37	2.01	2.05	0.06	2	2.01	2.32	15.94	34	
2 1/2"	10"	0.08	2.76	2.2	2.64	0.08	3	2.2	2.52	0.06	2.5	2.2	2.76	18.23	38	

Size	Actuator ø	Tri-Clamp ASME BPE				E1	Weight (~lbs)
		d	d2	c1	h1		
1/2"	10"	0.5	0.98	2.81	3.37	16.34	32
3/4"	10"	0.75	0.98	2.81	3.27	16.34	32
1"	10"	1	1.9	2.96	3.13	16.34	33
1 1/2"	10"	1.5	1.99	3.43	3.9	17.28	34
2"	10"	2	2.52	3.5	3.5	17.13	34
2 1/2"	10"	2.5	3.05	3.5	3.5	18.98	39

Dimensions in inch

Aseptic Right Angle Control Valve 6051

shut-off valve with butt weld ends according to DIN
and motor drive type 2030



Dimensions and weights

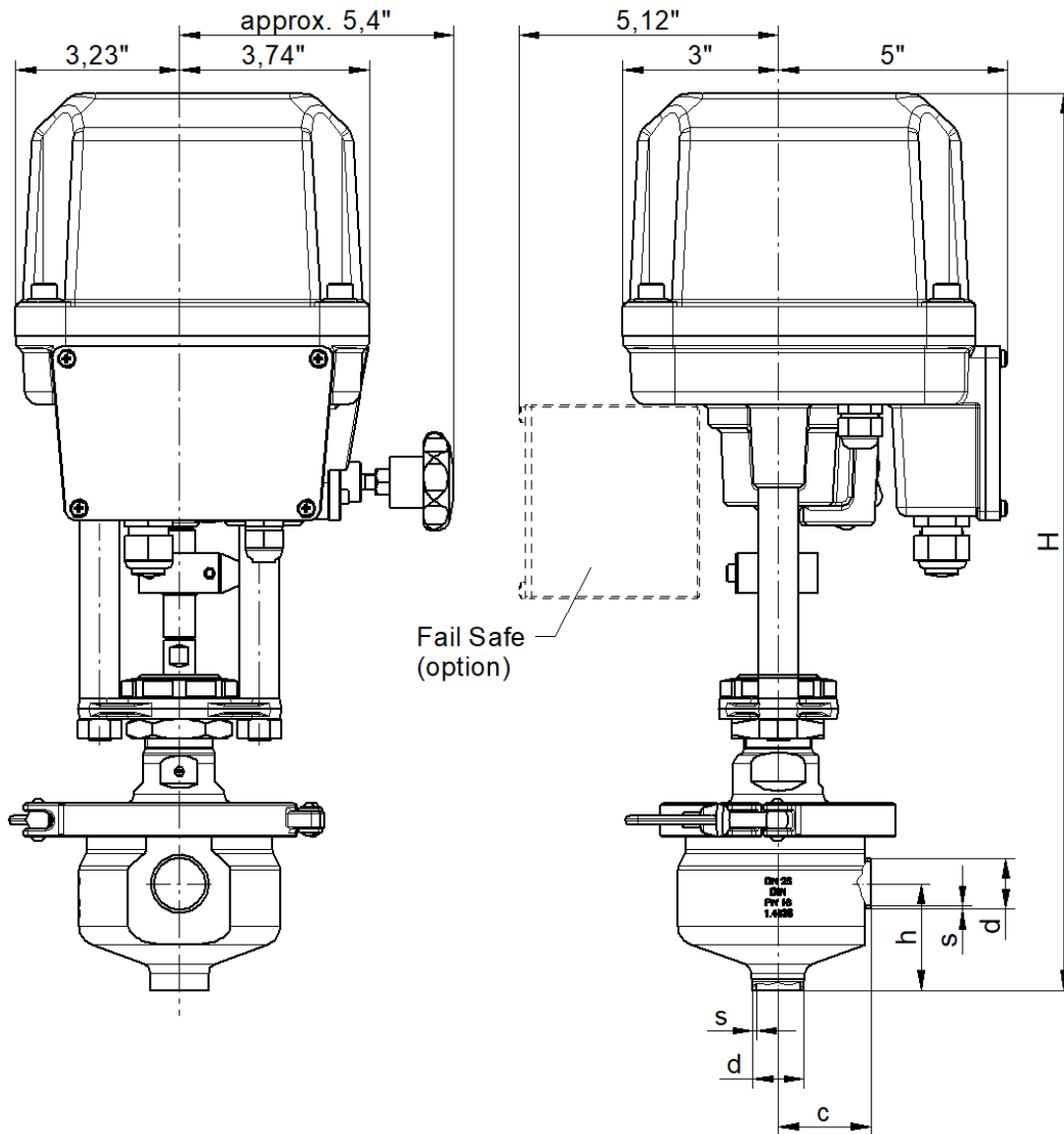

DN	Connection acc. DIN				Height H		Weight 2 kN (~ lbs)		Weight 5 kN (~ lbs)	
	s	d	c	h	2 kN	5 kN	without Fail-Save	with Fail-Save	without Fail-Save	with Fail-Save
1/2"	0,06	0,75	1,83	2,11	17,48	18,74	26,1	29,8	28,1	31,8
3/4"	0,06	0,91	1,83	2,11	17,60	18,86	26,1	29,8	28,1	31,8
1"	0,06	1,14	1,83	2,11	17,72	18,98	26,3	30,1	28,3	32,0
1 1/2"	0,06	1,61	1,95	1,89	17,76	19,02	27,4	31,2	29,4	33,1
2"	0,06	2,09	2,01	2,05	18,23	19,49	28,3	32,0	30,3	34,0

Dimensions in inch

Aseptic Right Angle Control Valve 6051

shut-off valve with tri-clamp ends according to ASME-BPE and motor drive type 2030



Dimensions and weights

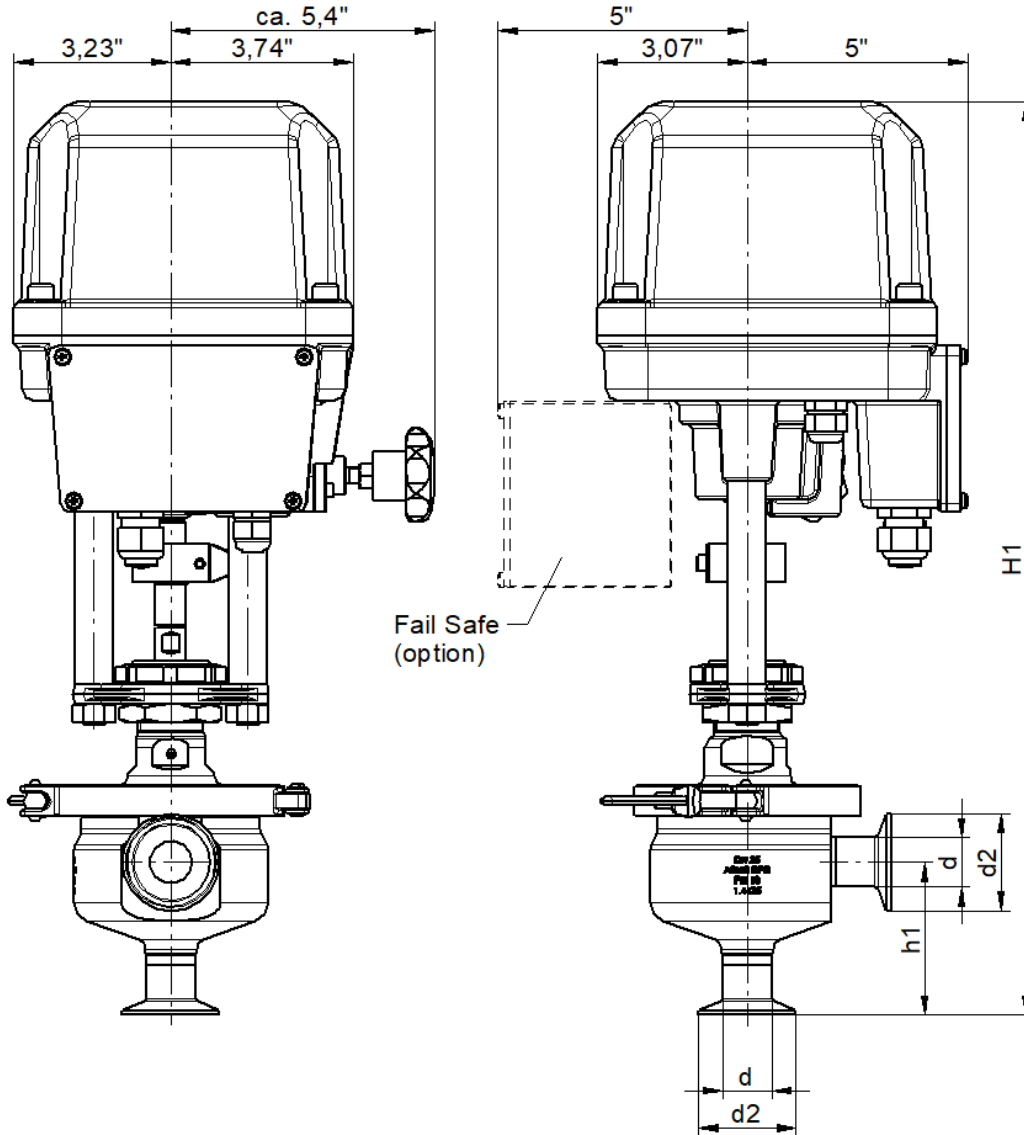

DN	Tri-Clamp acc. ASME BPE				Height H		Weight 2 kN (~ lbs)		Weight 5 kN (~ lbs)	
	d	d2	c1	h1	2 kN	5 kN	without Fail-Save	with Fail-Save	without Fail-Save	with Fail-Save
1/2"	0,50	0,98	2,81	3,37	18,50	19,76	26,1	29,8	28,1	31,8
3/4"	0,75	0,98	2,81	3,27	18,62	19,88	26,1	29,8	28,1	31,8
1"	1,00	1,99	2,96	3,13	18,74	20,00	26,3	30,1	28,3	32,0
1 1/2"	1,50	1,99	3,43	3,90	18,78	20,04	28,3	32,0	30,3	34,0
2"	2,00	2,52	3,50	3,50	19,25	20,51	28,7	32,5	30,7	34,5

Dimensions in inch