

Pinch Valve for endless tubes 7072

1/8" up to 1/2"



Pinch valve for special applications in chemistry, foodstuff industry and dispensary.

- Fast and simple change of flexible tube
- Change the fixing-pieces for using tubes of other diameter
- No room for dirt, easy to sterilize by steam
- Stroke limitation for smooth closing
- Pneumatic actuator

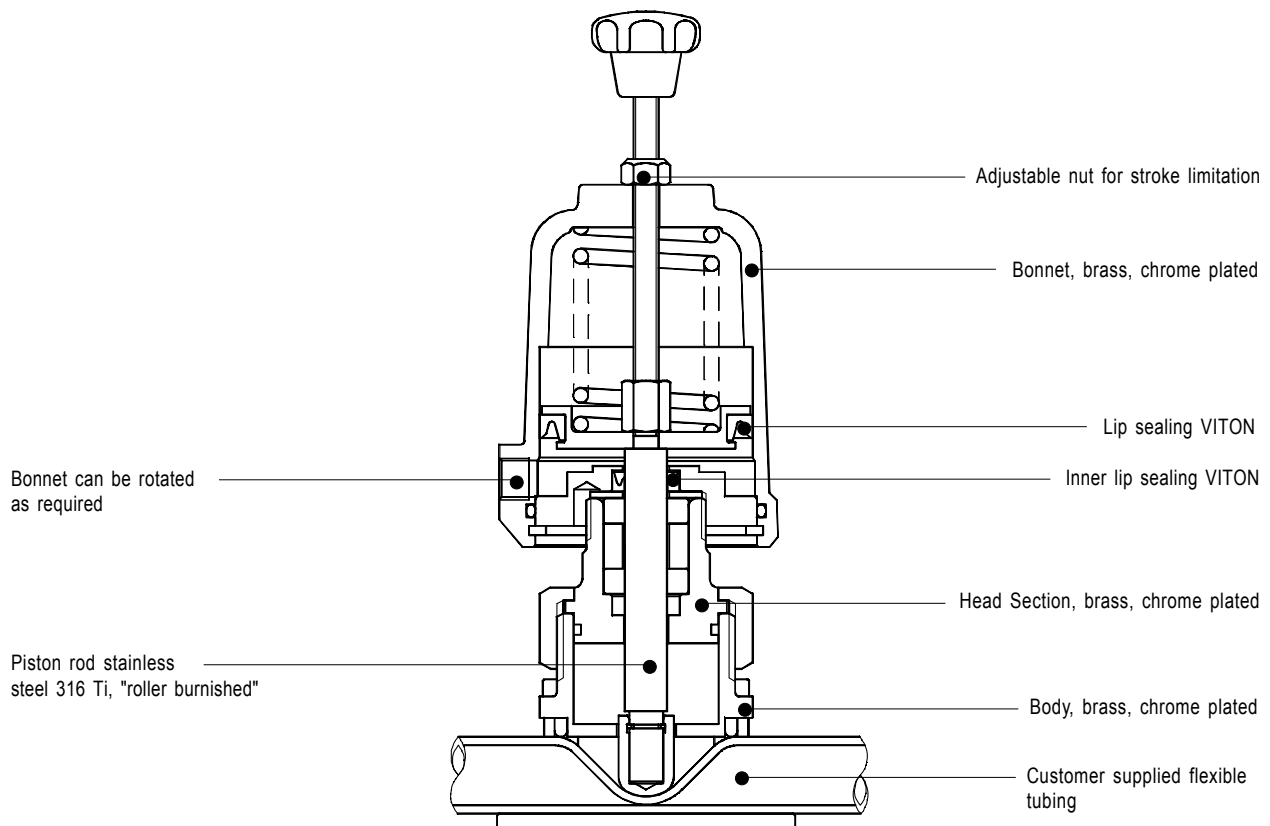

Pinch Valve for endless tubes 7072

Technical Information

Tube (inner diameter)	1/8" up to 1/2" (in steps of 0.08 inches)
Tube (outer diameter)	1/2" up to 5/8" (in steps of 0.08 inches)
3 interchangeable fixing pieces	3/8" - 1/2" - 5/8"
Body material	brass, chrome plated
Working pressure	0 - 90 psi (according to the quality of the tube 50 - 70 Shore hardness)
Tube types	up to shore hardness 65°A
Pilot pressure	35 - 145 psi
Thread for pilot connection	G 1/8"
Fluid temperature	-22°F up to +338°F (according to the quality of the tube)
Ambient temperature	-22°F up to +140°F
Viscosity of fluid	up to 0,001 m ² /s (1000cSt, 132°E)
Weight	3.5 lbs

Dimensions

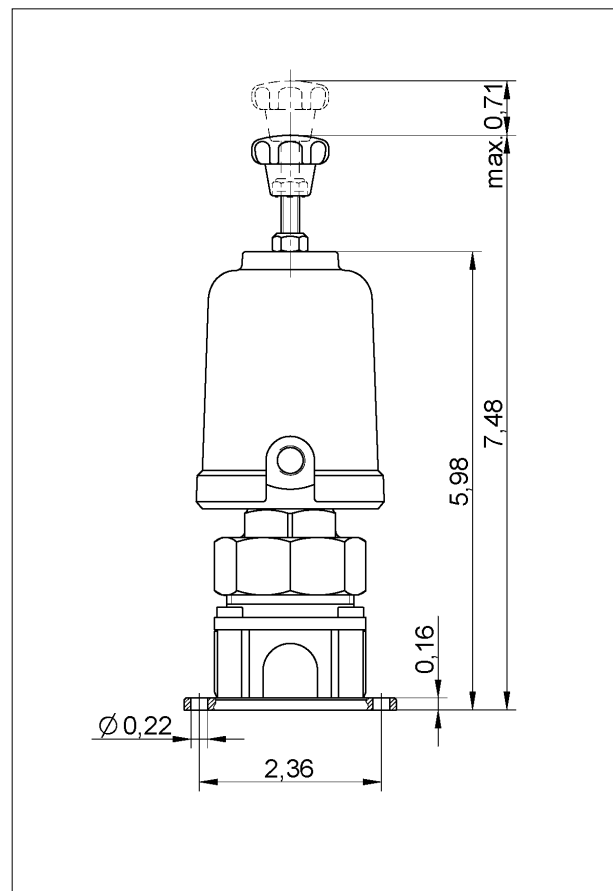
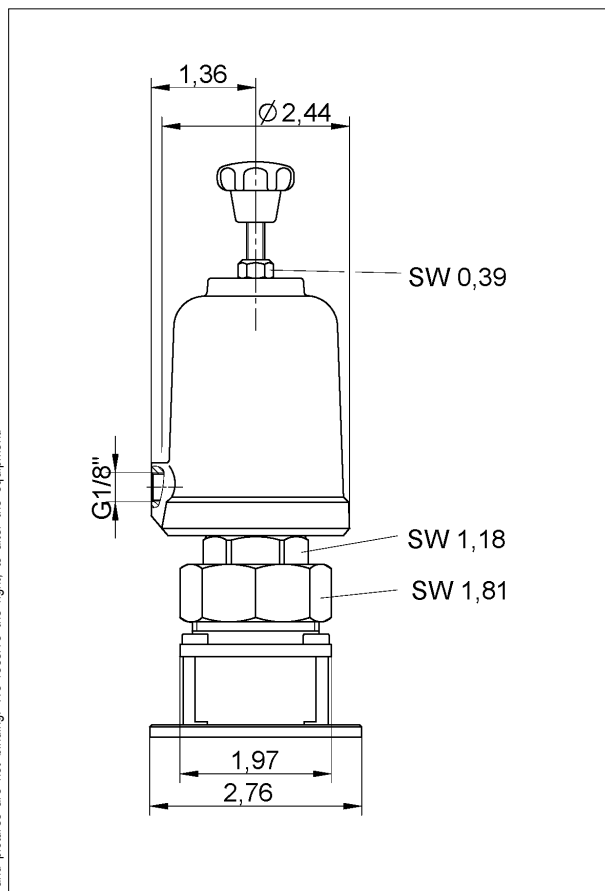

Text and pictures are not binding. We reserve the right, to alter the equipment.